

Nominal fee: 8,90€



Der Franzose



Citroën Peugeot Renault



www.franzose.com | ☎ 00 49 44 41-91 61 910

CITROËN Type H

HY

Retro Future 1



content

1 engine + gear box 0100-0113

replacement engine.....	0100
engine gasket sets.....	0101
engine block.....	0102
engine + transmission suspension.....	0103
cylinder head.....	0104
cylinder head gasket.....	0105
crankshaft-camshaft-piston-flywheel.....	0106
oil feed + oil cooling + oil filter.....	0107
engine + transmission oil.....	0108
transmission.....	0109
gearshift mechanism + linkage.....	0110
differential.....	0111
hydraulic.....	0112
hydraulic fluid + brake fluid.....	0113

2 outside of the engine 0201-0215

intake and exhaust manifold.....	0201
exhaust system.....	0202
engine cooling.....	0203
carburetor + carburetor gasket sets.....	0204
gas manipulation + gas cable + choke cable.....	0205
air filter.....	0206
fuel system (pump, lines, transmitter, tank).....	
ignition.....	0207
clutch.....	0208
clutch cables.....	0209
generator + spare parts.....	0210
V-belt.....	0211
starter.....	0212
heating + ventilation.....	0213
(ventilation shutter 2cv).....	
engine electric.....	0214
	0215

3 suspension + steering..... 0301-0312

wheel bearings.....	0301
front axle.....	0302
rear axle.....	0303
drive shaft.....	0304
drive shaft sleeves.....	0305
shock absorber - suspension balls.....	0306
suspension, spring struts, suspension cylinder.....	0307
tyres + rims.....	0308
steering column - steering wheel.....	0309
steering gear.....	0310
steering rods.....	0311
ignition locks.....	0312

4 brakes..... 0401-0412

pedal gear.....	0401
front brake without hydraulic parts.....	0402
rear wheel brake without hydraulic parts.....	0403
brake line prefabricated + hydraulic lines.....	0404
brake lines + accessories, yard goods, universal.....	0405
brake hoses.....	0406
main brake cylinder.....	0407
wheel brake cylinder rear.....	0408
hand brake.....	0409
hand brake cable.....	0410
caliper.....	0411
wheel brake cylinder front.....	0412

5 electric + dashboard..... 0501-0514

cable tree.....	0501
cable tree accessories.....	0502
illuminant (light bulbs) 12 volt.....	0503
dashboard + accessories (control instruments inside).....	0504
speedometer cable.....	0505
battery + holder.....	0506
headlights + accessories + holder.....	0507
turn signal, indoor lighting.....	0508
rear lighting.....	0509
washing system.....	0511
electrical component parts, other.....	0512
radio.....	0513
ignition lock.....	0514

6 bumpers..... 0601-0602

front bumper.....	0601
rear bumper.....	0602

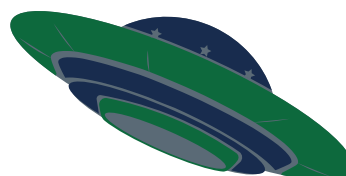



7 vehicle body 0701-0719

chassis.....0701
 rear body components.....0702
 floor panels.....0703
 welded body components.....0704
 doors front + rear + attachments.....0705
 luggage compartment lid +
 attachments, rear do.....0706
 emblems.....0707
 front wing.....0708
 rear wing.....0709
 engine bonnet + front panels +
 radiator grille.....0710
 body seals.....0711
 door locks + handles.....0712
 door pane + attachments.....0713
 remaining glazing.....0714
 top + soft top hoods.....0715
 tow coupling + accessories.....0717
 mirror.....0718
 decoration sets (glue sets).....0719

8 body covering 0801-0812

dashboard lining.....0801
 body inside lining, head lining,
 rear window shelf + trunk.....0802
 sun screen, inside mirror.....0803
 seat belts.....0804
 seat covers front.....0805
 seat covers rear.....0806
 complete seat covers (sets).....0807
 seat frame + attachments.....0808
 upholstery + suspension seats +
 material.....0809
 door trim.....0810
 carpet sets + floor mats.....0811
 insulating mats generally.....0812

9 chemistry + lacquer 0901-0908

lacquer 1 liter... 0901
 color spray cans.....0902
 lacquer chemicals.....0903
 rust inhibitor + body sealing.....0904
 gasoline additive.....0905
 useful chemistry.....0908

10 chrome + beautiful + useful . . . 1001-1006

trim strips.....1001
 hub caps.....1002
 chrome parts.....1003
 other beautiful attachments.....1004
 racks.....1005
 car cover.....1006

11 tools 1101-11042

special tools for motor vehicles.....1102
 tools generally.. 1103
 screws + nuts.... 1104
 electrical material generally.....1105

14 literature 1401-1405

repair manual... 1401
 operating instructions.....1402
 spare part catalogue.....1403
 sales catalogue „Der Franzose“.....1405

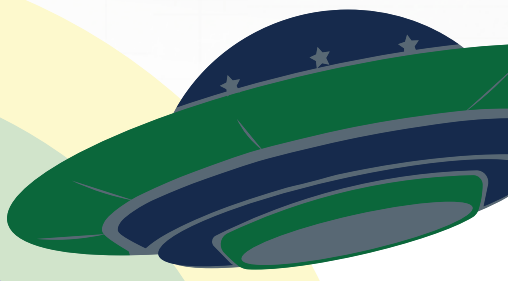



Ansgar Olberding



Farina Wilke

Future is retro

Bonjour,

I'm just back from the cinema. What can I tell about this film? A sci-fi story with the usual familiar themes: greed, power, life death and romance.

On my way back home; I'm still thinking about the „silliness“ that has been shown as the future. Somehow, everything in this genre has already been portrayed: motor-bikes without wheels, means of transport that think and talk to you (a kind of car), laser-assisted gadgets and so on. And in the end, everyone gets killed by a sword.

And at that moment, Fantômas comes to mind, a marvelous futuristic delirium , where I saw then the flying DS. Or, for me much more obvious: „Back to the future“ in the 1980s.

It's „Back to the future“ that concerns me the most. Skateboards without wheels (existing wakeboard), single-wheeled scooters, cars that talked and operate like time machines. In this film, flat screens were hanging all over the wall - at that time, no one had any idea that the future will look like this. Everyone is communicating via video calls, Skype-like and a display indicates who is calling beforehand.

Finally, almost home, I'm thinking more

and more about „today“. Indeed, we actually have arrived more or less in the future, or even far beyond.

Cars have been talking to us for a long time now, hitting on the brakes automatically, beeping and roaring like a beast with rabies.

Transmitting a photo rapidly, wireless, has become completely normal.

Another example: our company. Since 2023, we no longer have a gas connection. We produce electricity with solar panels on the roof. This electricity is being used to run the machines, which draw heat from the air, heating then the entire building, several offices and warehouses. And this process even works in winter.

LED lamps have replaced the good old neon tubes. The computer indicates in real time how much electricity is being produced in excess and saved into the network.

A friend of mine drives a hydrogen car. There's only water coming out at the back. Everything is normal.

And I use synthetic petrol (so-called e-fuels) in my 2cv, a fuel produced solely from CO₂ + water and lot of electricity (I'm doing this for a study).

And now let's move on to our cover photo for the new catalogues. A UFO hovers over a 2CV. A wild column of numbers are teleported. Crazy, isn't it? May be! For the first time in 37 years, there's a major change in the Der Franzose Cataloges.

Instead of a price list, there are QR codes next to each item. A single scan with your smartphone gives you the current price, lots of photos, videos and PDF files on the technique.

Science-fiction, here we come!

Yes, I know, the „good old days“ with the prices in the catalogues were great. And yes in the „good old days“ things were different. The prices were fixed for a year and not for few weeks like nowadays. But at that time, you also had to sail to cross the Atlantic.



Some of our reasons behind this approach is the electric cars, which made huge progress. Which car manufacturer still invests in radiator, water pumps, ignition contacts and coils, exhaust system, radiator hoses, window handles, alternators, starters? It all have to be produced somewhere in the world! The prices of raw materials go up and down, a cargo ship in the Suez Canal can paralyse the entire global economy! And yes, in the good old days, things were not such. And the situation in Russia, Ukraine or Middle East reminds me of the „not so good old days“. Everything is happening again.

That's the way it is. The QR code is now firmly established and that's a good thing. Obviously, things are running better and much faster thanks to the QR code. One positive result is that, not only you can see the price but also the current availability of each part. And finally, it also contributes to the protection of the environment when we avoid printing over 25 tonnes of paper annually.

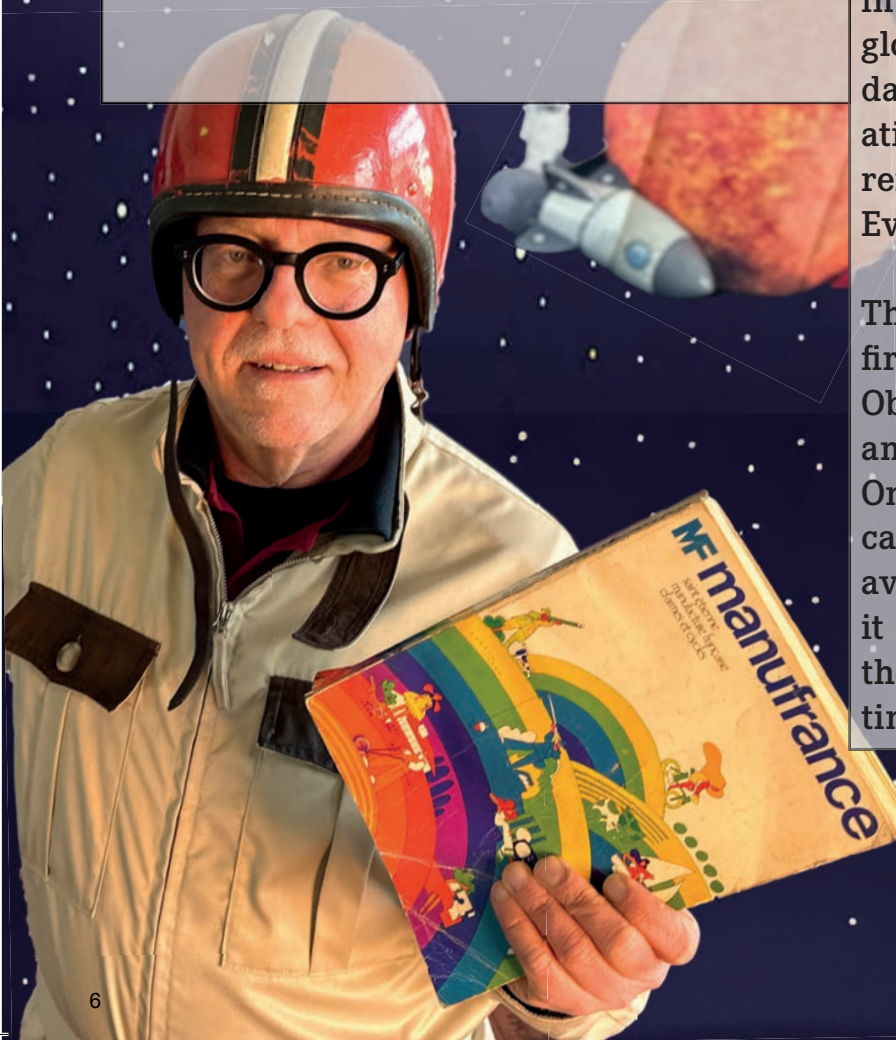

That's why we're naming the new edition: RETRO-FUTURE 1. And later RETRO-FUTURE 2 might follow. But not every year.

RETRO_FUTURE 1, here we go. So, now enough of speeches. I jump in my 2CV and start the engine analogously, powered by e-fuel. I simply can't get enough of this „greenie“ 2cv.

Digitalisation as much as is useful to me, nothing more, nothing less.

Ironically, on the other side of the road, a young man looking pretty annoyed, is waiting for his electric car to be charged. Like an unforeseen interruption in his time schedule.

I simply turn on the ignition key, give him a gentle horn and drive off.

Until then, thank you for your trust.

Ansgar Oberding



QR-Code - Quick. Easy. Direct.



Open camera-app →



Scan QR-code →



See price, photos and infos!

No installation needed – the app starts automatically!
Setup language & region once – ready to go!



... here a bit more vivid : scan, find, repair

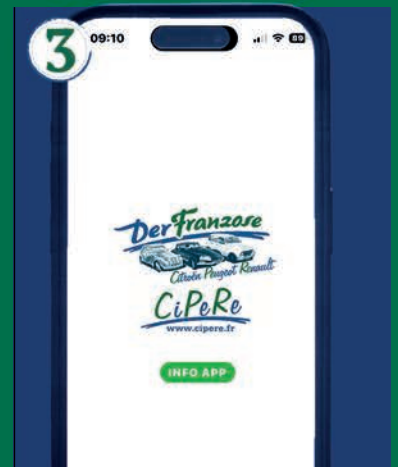

Scan QR-code with a smartphone: unlock smartphone. Open camera-app. Hold the QRcode in the camera's field of view. Tap on the banner that appears. (just once : link to the app)

... the app installs automatically – and just like that you can scan the prices

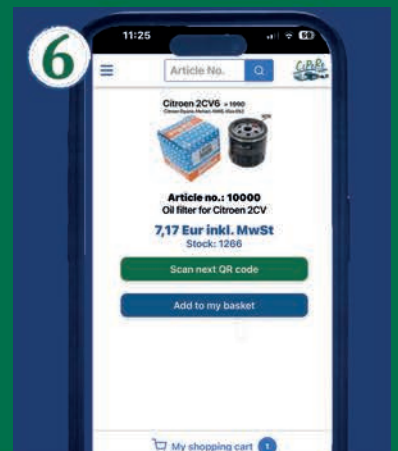

Please allow camera access (varies depending on the device), for the app to work.
Point the camera at the QR-code of the desired product. As soon as the code is recognized, the app opens the product page with all important information..

You want it even easier?

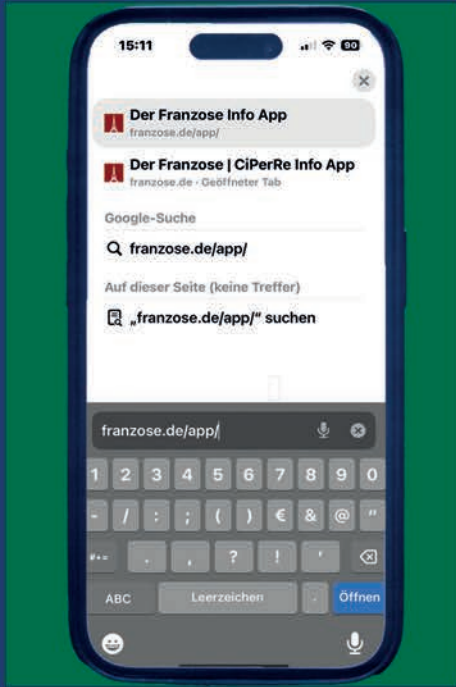

Just type in
franzose.com/app
at the top – where you
would normally open
Google or other websites.
Then the app starts.

Tipps, tricks and other functions

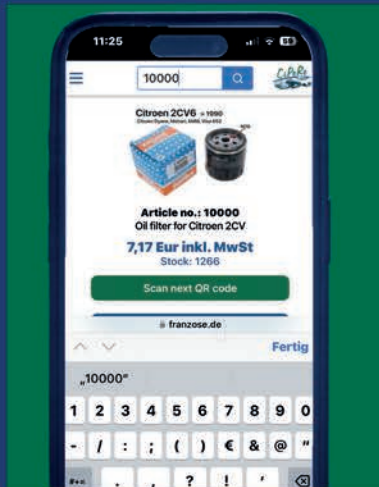

Enter article number directly –
without scanning

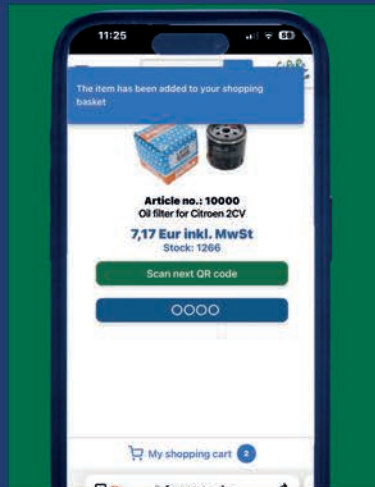

Add item to cart and
order immediately

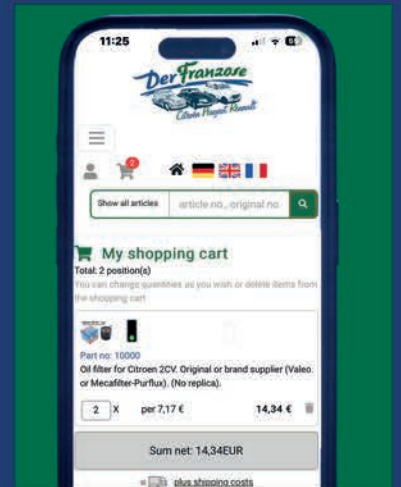

Order directly in the shop ... and
continue to work on the vehicle

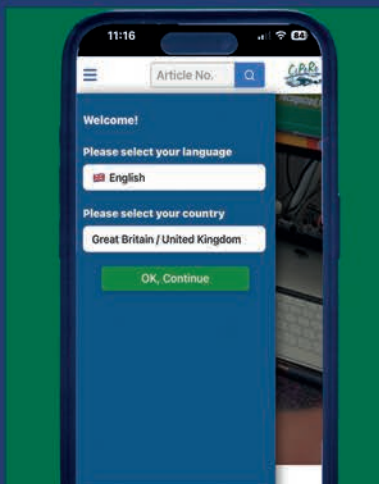

Select and specify the language and delivery/billing country. You will always be
shown the correct price including the VAT applicable for your country!

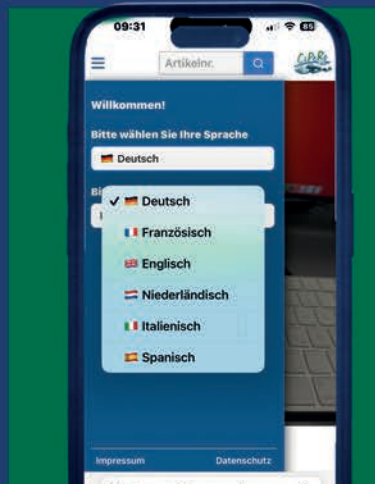

Expert Tip:
iPhone: Tap the share icon (square with
an upward arrow) at the bottom.
Select "Add to Home Screen" and tap "Add."
Android: Tap the menu (three dots) in
the top right. Select "Add to Home Screen,"
tap "Add," and confirm.
The icon will now appear on your home screen.

We look forward to your call

+ 49 44 41 - 91 61 912

Team Franzose

We speak
7 languages!
English
German
French
Swedish
Spanish
Italian
Creole



Our History - or - The „Club of the crazy“

I grew up in northern Germany, in the district of Vechta, a strict catholic and conservative region, but yet my hometown. In 1987, I completed my apprenticeship as car mechanic at Mercedes. In that wonderful summer, I knew for sure: I no longer wanted dealing with cars - I have to do something different! And why not? At that time, the world seemed alright for me - there were clear structures: the young generation were either punks (waver), „Popper“, greenies or the normal-minded one. I belonged to the first category! I've always been an outsider anyway.. For me, somehow everything never really minded but at the same time, everything seemed possible. Thus, I spontaneously bought three 2CVs for DM 300 and then (for that one it took a little bit longer), I completed three further apprenticeships. One thing was pretty certain for me that time: I did not know what I really wanted but I surely knew what I didn't want! From the three 2CVs, I only get one (more or less) working and I had experienced so much with it: I simply enjoyed life in it. Growing up in a village, I was able to break out of the confines with my 2CV, enjoy freedom, escape the stale life. So, I spent the nights drinking beer at the lake, smoked my first joint in it - of course with the roof opened, kissed my first „dream girl“ and so on, attended my first open-air concert, and more and more adventures. Later, after the educational but not really enjoyable apprenticeship, I read a great, probably not very serious report in the newspaper: According to the statistic, 1 cigarette shortens life by 2 minutes, 1 glass of brandy by 4 minutes, whereas a job which we do not really enjoy, shortens life by 8,5 hours a day. So, my girlfriend at that time (actually my wife for a long time) and I thought that we can take the risk what concerns position 1 and 2. However, regarding position 3, something has to change. That's how it came about. From the very modest beginnings in a flat-sharing accommodation on a farm, with many deprivations (we had to hold back a lot on position 1 & 2 in order to still have money left over for food), a considerable company has grown up since 1993. And we, my wife and I, can honestly say that the „work“ has not shortened our lives, but enriched them extremely. We will not go into the numerous steps in between from 1993 until today. But one thing is sure: we are still the outsiders, who we used to be, hence considerably older, a few grey hair, more appropriate and wiser - at least according to us! And mavericks prefer dealing with mavericks and other „crazy“ people. And today, we are a colorful bunch of over 30 people, arranging sending car parts worldwide (which I never expected and actually didn't want). But well, it works fantastically! Well , I still restore my French 2CVs, DS, Renault and Peugeot with greatest delight. I try various reproductions and drive in the bright season daily in my little „treasures“, especially in the 2CV.. That's just a sentimental thing, you know!

A portrait of Ansgar Olberding, a man with white hair and glasses, wearing a red shirt, smiling. The portrait is tilted and overlaid on the bottom right of the page.

Ansgar Olberding
Purchasing Dept. / Parts Controller

Ey come on,

you wouldn't be reading this if you weren't also a bit crazy, right? Also had beers or wines or any other weird drinks in your very first car..cuddling with the first boyfriend or girlfriend ...Didn't you love the first car as it gave you the feeling of freedom, which you were longing for? Don't you also feel nostalgic while seeing that „very first car“ on the road again? And perhaps, you have now recaptured your youth with your old French car: this driving piece of your own life story with a particular stylishness. Perhaps, according to today's criteria, it may not be pretty, but charming, pragmatic, with which you are always „well-dressed“. Today, we have the spare parts for that „charming lady“! More than 1 million parts can be found in our warehouse. And our wonderful crazy team is happy to assist you, via e-mail, phone or even in person.



I'd like to introduce you to some of the eccentrics here:

There is the other *Ansgar*, to whom you can call out by passing by: „Ansgar, give me the color code for the bumpers of a 1957s 2CV!“ And he will give you the code straight away, just like that!

Holger: An extensive technical knowledge meets a childish obsession with DIY. He developed the regulated catalyst for the 2CV and the R4. He explored the fuel injection systems and slams on the brakes when an old tractor peeked out of a barn.

Frederic, the first authentic frenchman here. He is a graduated french-german synchronic translator and has worked for the EU in Brussels. But somehow, yes somehow, he prefers old French cars than politician' words. And here, he can pursue with his passion.

Hugues: Comes from Kongo and was a professional soccer player. Today, he sometimes kicks the phone off his desk when it gets too stressful... ;)

Anna from Sweden. I met her on a language course and years later, I met her again at a really good party and knew straight away that she was the one. Perfect match.





Farina: the initially quiet little mouse! She had learnt something about taxation and so on but didn't really like it. So she decided to work as stewardess and lived for a long time in London. Today, she is here with us and still has to deal with taxes and accounts.. Well, that's life. I know what I'm talking about, I first learned car mechanic...



Steffi (my wife) does everything, can do everything, and if for once she really can't do something, she can admit it. Really powerful! She remembers every birthday and organizes toilet paper for everyone here.



Kai: a real north german. Not very talkative. Worked for a long time as a mechanic for speedboats all over Europe and before, lived in Canada for 2 years. So, there was already an indirect connection to the French affinity as french is the official language in Canada.



Neeroosha: an unpronounceable name meets north german monosyllable. Exciting! Born and raised in Mauritius, she is blessed with an extensive knowledge of languages. English, French, creole, anyway, that's her mother tongue, in addition to this, perfect german and good italian. No idea how she does that.



Arminda: Young globetrotter from Bolivia. She has already seen more of the world than I ever will. She speaks spanish and english and her german is getting better.

Those two little ones, Neeroosha and Arminda rock the international office. The purest linguistic laboratory!



Heiner: the eternal DJ, working with us between the weekends. He manages everything regarding the web shop, catalogue design, pictures etc. Amazing!



Michael: the other nerd. Pale as a piece of paper, computer software is his world. He also occasionally performs as DJ.



There are so many other committed people here: Ruth and Andrea, the two sisters who conduct the ballet of order pickers and packers (Nadine and Kerstin from Germany; the eternal biker Detlev; Brigitte and Birgit, who are actually already part of the inventory; Derya from Turkey; Claudia, the former bakery saleswoman,) and dance along themselves.

Else, who is actually called Elke in Controlling, Heiko, as a master metalworker, who meticulously measures everything in the incoming goods department. Helping hands are Thomas, Dana and Carola, who also ensure that everything is put back in the right place in the incoming goods department.

I'm the boss, who isn't really much of a boss at all. I've given most of the tasks to the crazy people. But I'm only too happy to do the purchasing, the search for rare items, the instigation of remakes and the testing of parts. And I always take the photos for the online shop myself.

Yes, it's a club of crazy people.

And if you are also at least somehow crazy, have rediscovered the youth car, or own it again or still own it, then you are at the right place. We can help you, keeping your „lovely“ in a good running condition, or may be in a better condition than before. You can also personalize it too as the range of spare parts (seat covers, roof colours) has never been wider than today.

Just have a look upon opportunity in our printed catalogue.. yes, we, crazy people still have printed catalogues. Online , on our website is also possible anyway.

You can order your favorite item 24/7 via our webshop, no matter where you are situated. Your parcel will be delivered within few days. By the way, you can as well see immediately if the required item is available in our stock or not. 95% of them are indeed on stock. And for further query, our crazy team is available via phone and can assist you in French, english, swedish, spanish or german. For all other languages, just give it a try.. and who know, may be you can catch someone who can speak that language too.

And now, a very personal statement from me:

the world has gone mad. Everything has to be faster and faster.. The „beloved“ car has been kept around in the heated garage for 30 years, but the spare parts have to be delivered within few hours after the order has been placed! Honestly?! I can't really understand that. It might work sometimes but not always. Our crazy team, by the way all permanent employees are well salaried for a normal standard living, would also like finishing their work on time; you know: 2 minutes for a cigarette, 4 minutes for a drink and then it has to end...So, if it takes a day longer, you can still rest assured that the parts will be sent to you.. bien sûr!

PS: Regarding, le „savoir-vivre“, did you know that almost every French car has a convertible seat, whereas german cars almost never had them.. Give it a try!

Take care.

Yours,

Ansgar Olberding



Brigitte



Birgit



Nadine



Andrea



Thomas



Claudia



Ruth



Kerstin



Elke



We ensure that your car is being maintained for a longer time!

Detlev



Dana



Carola



Heiko



Derya



Even more information about our team is available online!



SUSTAINABILITY

don't talk about it, do it

E
C
C
O
L
O
G
I
C
A
L

E
C
C
O
N
O
M
I
C
A
L

S
O
C
I
A
L

What does sustainability actually mean?

Basically, it's quite simple. It means using a product over a long period of time as far as possible so that no unnecessary new production is required. The question is whether it is really sustainable to switch completely to electro-mobility.

Don't get me wrong: there's no objection to electro-mobility when a car breaks down and needs to be replaced. But does it have to weigh 2.5 tons and speed up to 100 km/h in 4 seconds? Does it have to be bought as a luxury symbol? Isn't that the wrong strategy?

You and we, both of us are particularly sustainable when it comes to the first point: Using old and low-weight cars for as long as possible. Then fill them up with climate-neutral fuel (e-fuel) et voilà, we are all considerably more sustainable.

We have already implemented many things in the company in recent years, but never talked about them (because it was obvious). We have replaced almost all plastic bags with paper bags, and have been doing so for years.

We source our packaging materials from a factory, just 50 kilometers away. Since 2010, we



have replaced most of our adhesive tapes with paper-based wet adhesive tape. We have also been operating a combined heat and power unit since 2010.

This has been replaced by heat pumps at the end of 2023. We replaced the 521 fluorescent tubes with LED lamps years ago .

Oh yes, of course we also installed a PV system with an output of 99.75 KW! Actually, 99.75 KW is far too much for our business. But in summer, we feed the surplus electricity into the grid and in winter the system still produces enough electricity to power all our appliances. We can therefore say that we have been able to generate our electricity, heat and cooling in a completely climate-neutral way since the end of 2023.



Through slow but steady growth, we have been able to put our company on a solid financial foundation. This has enabled us to maintain our independence.

In our business decisions, we are free from the influences and constraints of any investors. This allows us to devote ourselves entirely to the subject of „French classic cars“ in the interests of our customers, based on our long-standing experience. It is meaningful and pleasant to be able to respond to the wishes of our customers, without having to consider the interests of external investors.

Just wanted to briefly mention that. It is not sufficient to just pride ourselves for doing or intending to do this or that. It helps us all if we just do it and not only speak so much about it.

Yours Ansgar Olberding

Der Franzose

Place your order directly on the exploded-view drawing.

The easiest way for everyone.

Fast and simple to find the needed part!

You can order the part you need directly from the exploded-view drawing. The illustration shows you a clear view of the assembled part of a component. Coloured markings show which parts are actually available for sale. And you can prepare your shopping cart directly from each drawing. The exploded-view drawing can be found next to the picture of the item. Only 1 click and you're in!

How to use this feature?

- 1 Click on the exploded-view drawing and open the detailed view.
- 2 Click on the coloured marking of the item.
- 3 Add item to the shopping cart using the button under the details.

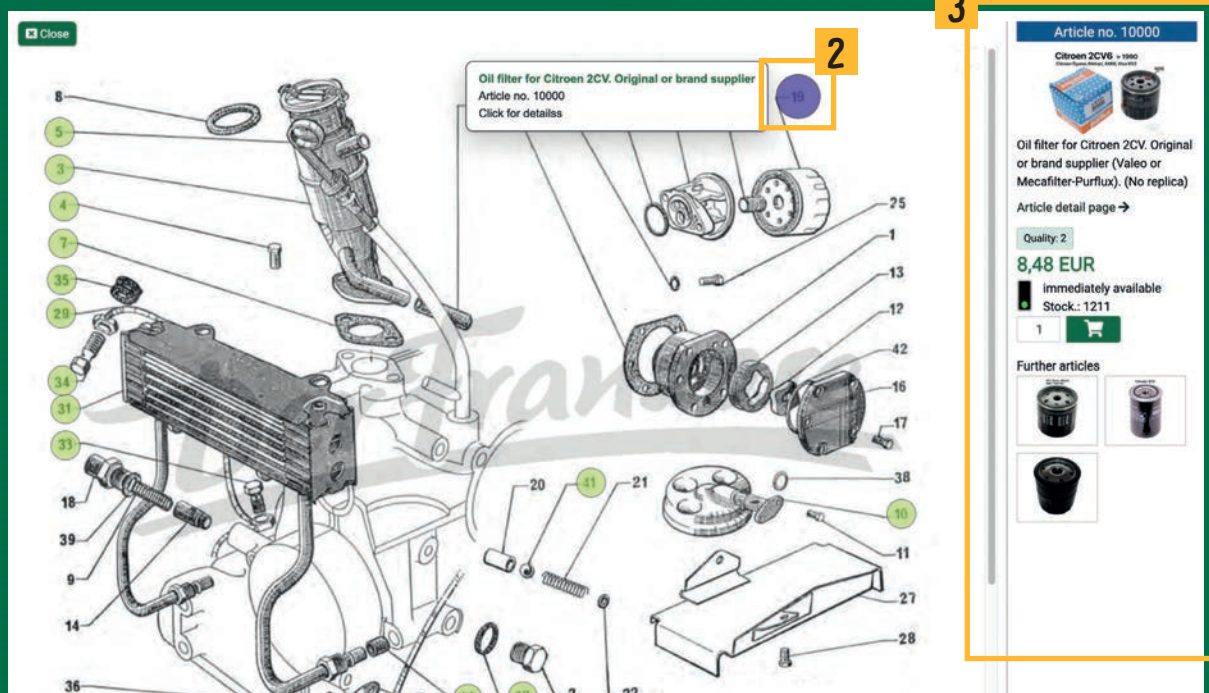
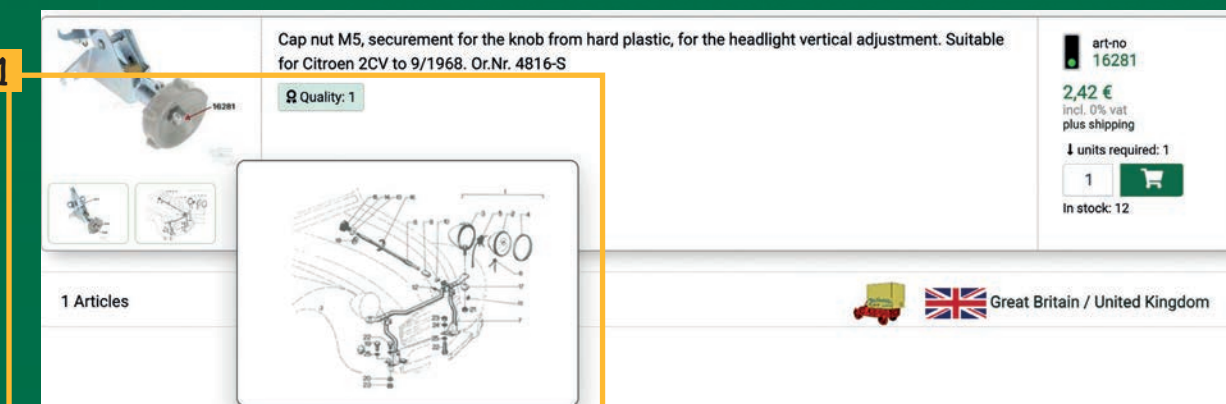

for free

Vintage literature

We offer a wide range of manuals and vintage catalogues for free download. These are original repair manuals, catalogues or leaflets. Simply click on „Books and Workshop“ at the top of the web page. You can refine the list by selecting the vehicle of your choice.

How do I use this function?

- 1 Click on „Books and Workshop“ in the main menu.
- 2 Select the model of the car.
- 3 Consult the documents in pdf format

Online for free



The screenshot illustrates the website's interface. At the top, the navigation menu includes 'Books Workshop' (highlighted with a yellow box and '1'), 'Contact Infos', 'Download Portal', and 'This & that News'. Below the menu is a search bar and a 'Show all articles' button. The main content area is titled 'Workshop manuals' and features a 'Choose model' button (highlighted with a yellow box and '2') and a 'Choose category' section with options like 'Repair manual', 'Spare parts catalogue', and 'Technical information'. A grid of manual covers is displayed, including 'Citroën Ami 6', 'Citroën 2CV', 'Citroën HY Vehicles HW (hydraulic rear)', and 'Citroën Visa, C15 Workshop Manual'. A specific manual, 'Citroën 2CV6 - Spare parts catalogue - from 1979 (last edition)', is highlighted with a yellow box and '3'. The bottom part of the image shows a preview of the selected manual's content, featuring a Citroën 2CV illustration and the text 'PIECES D'ORIGINE ORIGINAL-TEILE GENUINE PARTS PIEZAS DE ORIGEN RICAMBI ORIGINALI'.



How you order

You know what is missing in your car? You can find the right spare parts fastly and straightforward in our catalogue and directly place an order – also comfortably in our online shop. Thereby you need to notice few information about the parts. Both our printed catalogue as well as our online shop are similarly structured for you to orient yourselves easier:

Chapter, Categories and Attribution of the articles are identical here as well as overthere.

1 Name of the article & Description

Facts and details about the parts

2 Photo

3 Article number

Article number for orders or queries

4 Quality

- 0 = New Old Stock
(new original part but partially stored up to 40 years, possibly surface rust)
- 1 = Good
(upgraded original parts)
- 2 = Original
(original part or original supplier)
- 3 = Advanced replica
(reproduction – good quality, similar to the original part)
- 4 = Replica
(not as good as the original but good quality)
- 5 = Mediocre replica
(considerably worse than the original)

5 Needed quantity

That is the amount of items you need per car.
Please note: It is not the quantity delivered!

6 Price of the articles

including legal VAT, excluding the shipping costs. If the invoice and the delivery address is in a non-EU-country, we exclude the tax.

7 The old part deposit

To ensure further availability of particular items, we are reliant on the return flow of old parts. The deposit amount will be refunded via cheque / bank transfer / Paypal / credit card after submission of the old part. In the description of the article, you can find out if a deposit will be charged as well as the appropriate amount.

8 Availability

Trace light system

9 QR-Code

Scan with your smartphone and get the price for the item displayed directly and/or go directly to the online shop.

Katalog

1 Clutch set for Citroen 2CV6, starting from year of construction 03/1982. Reproduction, Made one in European Union. 18 teeth, diameters: 160mm. (Multi-disk) new part.

3 Art.No.	4 Quality	5 Qty
10175	4	1

Website

1 Clutch set for Citroen 2CV6, starting from year of construction 03/1982. Reproduction, Made one in European Union. 18 teeth, diameters: 160mm. (Multi-disk) new part.

2 Photo of the clutch set

3 Art.no. 10175

4 Quality: 4

5 Qty: 1

6 69,32 € (incl. 19% vat excl. 0,25 € EUR plus shipping)

8 Units required: 1

9 In stock: 14

What is where?

Here is an orientation guide to help you choosing the right part as one ask oneself sometimes, where is left and right.

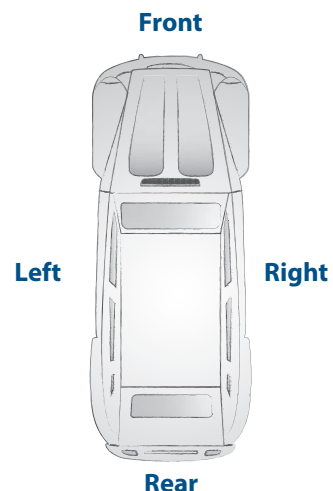



Delivery procedures

Der Franzose deliver your spare parts on a safe way until their destination via leading logistic companies, whether in Germany, Europe or worldwide. Further information about our terms of payment and shipping conditions here:

✓ Payment

You can comfortably settle your payment via credit card, Paypal or pre-payment.

✓ Delivery

We basically dispatch the parcels via local DPD/DHL. Big items (motors, chassis) are being sent via shipping agencies.

✓ Delivery insurance

For safety reasons, all parcels are covered by a transport insurance. Therefore you will be charged for the costs (appr. 0,92% of the value of the goods)

✓ For specific cases

Der Franzose assist your motorcar with high-class spare parts and dedicated service. Nevertheless for any discrepancies, kindly contact us. We will solve the problem!

Weight / Gewicht / Poids til	Zone 0*	Zone 1	Zone 2	Zone 3	Zone 4	Zone 5	Zone 6
	EUR	EUR	EUR	EUR	EUR	EUR	EUR
1 kg	7,99 €	11,90 €	16,90 €	19,90 €	27,90 €	36,70 €	44,70 €
5 kg	7,99 €	11,90 €	16,90 €	19,90 €	38,90 €	58,70 €	69,90 €
10 kg	10,99 €	16,90 €	25,90 €	27,90 €	54,80 €	87,60 €	112,90 €
20 kg	14,99 €	19,90 €	29,90 €	34,90 €	89,90 €	138,90 €	194,80 €
30 kg	21,90 €	29,90 €	39,90 €	42,90 €	118,90 €	213,00 €	279,85€
40 kg	29,90 €	39,90 €	54,90 €	59,90 €	168,90 €	277,80 €	389,60 €
50 kg	35,90 €	49,90 €	64,80 €	84,90 €	198,95 €	350,90 €	474,65 €
60 kg	39,90 €	59,90 €	79,80 €	104,00 €	234,00 €	426,00 €	559,70 €
90 kg	86,00 €	89,90 €	121,90 €	122,90 €	340,00 €	579,84 €	809,80 €

Long goods 1 (not automatically eligible packages), Condition: 116 to 170cm, width up to 56cm, length up to 56cm, volume up to 145 litres, Gross surcharge 11,90 €

Long goods 2 (not automatically eligible parcels with excess length), Condition: 171 to 245cm, girth up to 325cm, weight up to 31,5 kg, Gross surcharge: 49,90 €

Long goods 3, too long, too heavy, always manual work = forwarding surcharge, Condition: Length up to 245cm, or weight over 31,5kg, girth over 300, Surcharge gross 74,90 €

Zone 0	Germany, Luxembourg, Netherlands, Belgium
Zone 1	France (métropolitaine), Denmark, Italy, Ireland, Austria, Poland, Liechtenstein, Switzerland, Czech Republic
Zone 2	Andorra, Finland, Great Britain, Monaco, Norway, San Marino, Sweden, Slovakia, Spain, Hungary, Vatican City
Zone 3	Bulgaria, Croatia, Cyprus, Estonia, Greece, Latvia, Lithuania, Malta, Portugal, Romania, Slovenia
Zone 4 (most important)	Albania, Algeria, Belarus, Bosnia-Herzegovina, Egypt, Georgia, Iceland, Israel, Lebanon, Libya, Macedonia, Moldova, Republic of Montenegro, Russian Federation, Syria, Serbia, Tunisia, Turkey, Ukraine
Zone 5 (most important)	Afghanistan, Canada, China, India, Indonesia, Japan, Malaysia, Mexico, Oman, Pakistan, Papua New Guinea, Qatar, Philippines, Saudi Arabia, Singapore, Sri Lanka, South Korea, Taiwan, Thailand, United Arab Emirates, Vietnam
Zone 6 (most important)	Argentina, Australia, Bahamas, Bolivia, Brazil, Colombia, Costa Rica, Ivory Coast, Jamaica, Mauritius, New Zealand, Nicaragua, South Africa, Uganda, Uruguay, Venezuela, Central African Republic

Customs fees

For deliveries to non-EU countries and areas outside the Schengen Agreement, additional customs duties, taxes and fees may apply.

How our parts reach you

Your orders are being processed as soon as we receive them. We thus work together with one of the leading logistics company since we have more than 550,000 parts in our warehouse waiting to be dispatched. For example: 14,500 wheel brake cylinders stocked.

Here some more examples: from a range of 16.000 various parts, we dispatch every year more than 60.000 parcels in 90 countries, more than 6.100 galvanized chassis and 3.600 regulated catalyst for R4 + 2CV delivered in different countries.

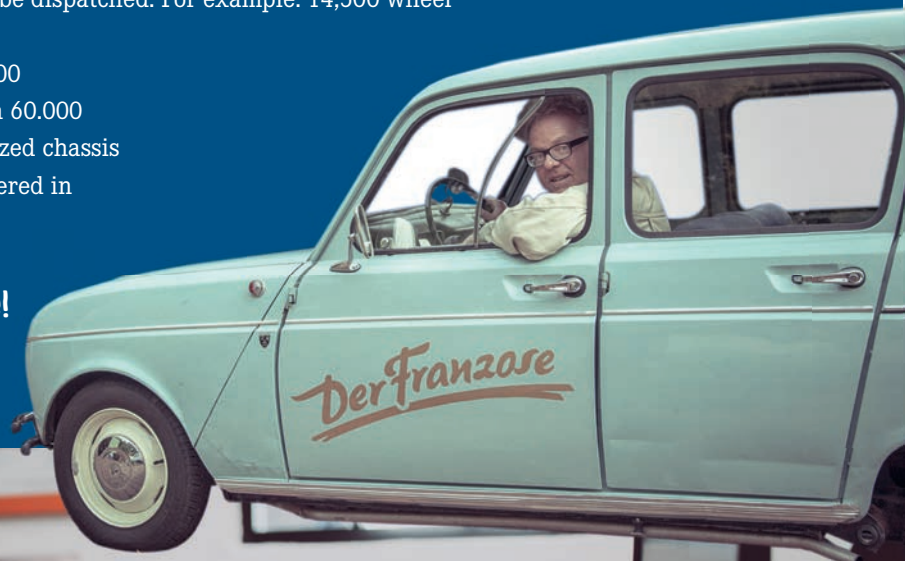

Fast and reliable delivery – Worldwide!

ORDER
INSTALL
BE
HAPPY
:-)



Other possibilities to order



Our online shop offers you the possibility to get a complete overview on all our parts. You can browse for the required parts even without a catalogue. Through the traffic light system in our online shop, you can immediately see if the required part is  in stock  temporarily not available  or out of stock for the moment.

www.franzose.com



Should you have any questions, our service team is personally at your disposal:
+49 4441 – 916 19 12



You can also send us your order via Email to the following Email address:
info@franzose.com

Shop





1

engine + gear box

replacement engine	0100
engine gasket sets	0101
engine block	0102
engine + transmission suspension	0103
cylinder head	0104
cylinder head gasket	0105
crankshaft, camshaft, piston, flywheel	0106
oil feed, oil cooling, oil filter	0107
engine + transmission oil	0108
transmission	0109
gearshift mechanism + linkage	0110
differential	0111
hydraulic	0112
hydraulic fluid + brake fluid	0113

Oil - Now, it's gonna be greasily complicated...



Most people think that oil change is very simple - buying the oil at the filling station and fill it??

It sounds very easy but for vintage vehicles, the modern oil is not really the optimal one for the motor. The new modern oil are thin fluid and contain much more cleaning additives which can ruin your motor.

Nowadays, the interval of oil change in modern cars with 50,000 km, is not an unusual condition. The modern oil has to be very thin to avoid that the filtration run smoothly, preventing sludge deposits and suits also vehicles with short distances. Whereas for vintage cars, oil change is done most of the time at specific season of the year! Oil is being renewed few weeks before the „hibernation“!

Vehicles like H-Van, Traction Avant, 2CV (until 2CV4) as well as many other vintage cars do not even have an oil filter. The impurities are set down in the oil pan and is being flushed out at the next oil change. That's exactly how it shall work! With the modern oil, it is the contrary which happens. The oil dissolved the impurities and pumped it again in the oil circulation. And this is wrong! Moreover, the material of the motor gasket of our vintage does not tolerate the chemical additives in the modern oil. Oil seals and rubber seal get harder through the additives and do not seal up

correctly. Cork seal get eroded and does not absorb any oil anymore and thus the motor leaks.

Just imagine, you take a plate full of noodle. On the lower part of the plate, you have 3 holes, pour some good olive oil upon the noodle. You can see how the noodle absorb that oil and underneath the plate, there is no trace of oil.

Now pour some soft drinks on the noodle. A pure chemical drink... now you can see that the soft drink does not get stick to the noodle and even wash out the good oil and the whole fluid are to be found on the plate and drop out slowly through the small holes in the plate!

Dear friends of vintage cars, this example with the noodle and the oil, is in fact a figurative one showing you what happens with your motor when you are using the modern high-tech synthetic oil.

So please hands off from all those modern synthetic oil.

Last but not least - our tip: the optimal oil for Citroën 2CV, DS, Traction und H-Van is 20W50. Even Renault R4, R5, R16, all rear-mounted engines (except Alpine) and all Peugeot like 203, 404, 204, 304, 404 und 504 are „grateful“ if the motor is being filled with 20W50!

engine gasket sets 0101



Engine gasket set (inclusive cylinder head gasket 1,5mm) Diesel. Suitable for engines: XD88, XDP88-BD, XDP88-BDS, XD90 (1948ccm). Bore: 94mm. Suitable for Peugeot 404 D, 504 D, J7 Diesel. Citroën HY Diesel. Installed from year of construction 1963 to 1975. Inclusive shaft seals. Or. No. 0198.14



Art.No.	Quality	needed qty
71134	2	1



Engine gasket set (inclusive cylinder head gasket) Indenor Diesel. For engine: TMD85, XDP85, TMD85-AD, XPD (1816cc). Suitable for Citroën HY Diesel. Peugeot of 403 Diesel, 404 Diesel, 504 Diesel, J7 Diesel. Without shaft seals. Or. No. 0198.24



Art.No.	Quality	needed qty
71131	2	1



Engine gasket set completely (inclusive. Cylinder head gasket). Manufacturer original "Glaser". Suitable for Citroën 11CV/11D + Citroën HY 78, to year of construction 09/1963.



Art.No.	Quality	needed qty
60361	2	1



Engine gasket set completely (inclusive cylinder head gasket). Suitable for Citroën HY 72 + 78 (bore 78mm = 1911ccm/ 72mm = 1600ccm), starting from year of construction 1963. The suitable liner seals have our article number: 60153. The cylinder head gasket of HY 72 + 78, are identically constructed! The cylinder liners are the same. They differ only in the bore!



Art.No.	Quality	needed qty
41010	3	1



Oil pan sealing set. Suitable for Citroën 11CV D engine + Citroën HY. Or. No. D113-97



Art.No.	Quality	needed qty
60370	3	1



Oil pan rubber seal (2 fittings), seal to the crankshaft. Suitable for Citroën 11CV D engine, ID19, DS19, HY. Or.Nr. D113-11 + D113-12. Made in Germany.



Art.No.	Quality	needed qty
30316	3	1



Oil pan seal, suitable for Citroën 11CV D + Citroën HY. Or. No. D132-9. Original one of "Glaser".



Art.No.	Quality	needed qty
60371	2	1

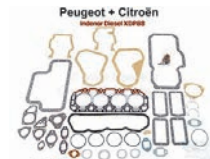

P 404/504/HY, engine gasket set Indenor Diesel XDP88. Bore 94mm. Suitable for Citroën HY Diesel + Peugeot 404 D + 504 D. Without shaft seals



Art.No.	Quality	needed qty
40002	3	1



Sealing paper set with and without metallic carrier! to produce own seals! Size DIN A4. Original "REINZ".



Art.No.	Quality	needed qty
20206	3	1



Used part deposit, what's that?

A lot of spare parts are no longer completely new fabricated. So special companies take back used parts to disassemble them. This single parts are going to be cleaned and lacquered, all flexible parts and pistons going to be renewed. After assemble them again, the parts are as good as new again.

However, we don't have so much used parts as we need and that is why we work with "used part deposit". For example: A distributor sends us a renewed brake calliper. Excepting the base price, we have to pay 50 €uro used part deposit for this part.

If we send back a suitable brake calliper, the distributor repays the 50 €uro.

We are also using this method: If you buy a spare part which is afflicted with used part deposit, you have to pay the selling price and the deposit. By sending back the replaced old part, you'll get back the deposit (just if the old part is qualified for an overhauling).

0102 engine block

1
2
3
4
5
6
7
8
9
10
11
12
13
14



Seal, for the cover plate at the engine block (left side of the engine block). Suitable for Citroën DS, starting from year of construction 07/61. Citroën HY, to year of construction 02/1970. Or. No. DF11485 + 1D5413624P.



Art.No.	Quality	needed qty
30153	3	1



Seal, for the division of the engine block, for the main bearing mounting. Suitable for Citroën HY, starting from year of construction 1959. Citroën ID19 + DS19. Or. No. D1329



Art.No.	Quality	needed qty
48117	3	1



14,5 mm

Frost threaded plug. Diameter: 14,5mm. Suitable for Peugeot Diesel., Citroën HY Diesel. Or. No. 0234.06. This frost plug can be ground to 14,2mm. Then it also fits in Citroën DS, HY petrol, 11CV. Or No. (14,2mm cover) 457.069 + ZC9457069U.



Art.No.	Quality	needed qty
72290	3	4



38 mm

Frost threaded plug. Diameter: 38mm. Suitable for Peugeot Diesel., Citroën HY Diesel. Or. No. 0233.06



Art.No.	Quality	needed qty
72291	3	1



Liner sealing ring down. Suitable for Citroën 11CV, 15CV, ID19, HY. Standard measurement of 0,07mm. Inside diameter: 83,5mm. Outside diameter 95mm. Or. No.: D1113A



Art.No.	Quality	needed qty
60153	3	4



Engine sealing compound grey, to 340°, 85ml, silicone basis. Optimally for oil pans, valve cap, valve timing cover. Very good quality. Made in Germany.



Art.No.	Quality	needed qty
20029	3	1



HYLOMAR engine sealing material, permanent elastic engine sealing, indispensable with engine overhaul, 80ml. Hylomar M is temperature resistant between -50°C and +250°C and can be applied for sealing sealing surfaces and threaded pieces.



Art.No.	Quality	needed qty
20027	2	



M16 x 1,5

Aimant / Magnet

Oil drain screw magnetically, suitable for Citroën 2CV, HY, DS, 11CV (with oil pan out of sheet metal). Interior square. The suitable tool has our number 20221. Or. No. A1321M, thread M16x1,5x20



Art.No.	Quality	needed qty
60123	3	1



M16 x 1,5

Oil drain screw (engine + gearbox) suitable for Citroën 2CV, DS, HY, GS. Thread M16.



Art.No.	Quality	needed qty
10002	4	3



M18 x 1,5

Oil drain screw (engine, Peugeot gearbox, Peugeot rear axle). Thread: M18 x 1,5mm (interior square). Suitable for Peugeot 203, 403, 404, 504, J7. Suitable for all engines. Renault R4. Citroën HY Diesel + AMI6 with M4 engine, AZAM6. Or. No. 0311.07 + 0311.04



Art.No.	Quality	needed qty
71065	3	4



M18 x 1,5

magnétique magnétique magnetisch

Oil drain screw magnetic (engine, Peugeot gearbox, Peugeot rear axle). Thread: M18 x 1,5mm (interior square). Suitable for Peugeot 203, 403, 404, 504, J7. Suitable for all engines. Renault R4. Citroën HY Diesel + AMI6 with M4 engine, AZAM6



Art.No.	Quality	needed qty
71427	3	4



M16 x 1,5

Oil drain screw with valve. Thread M16 x 1,5. This valve is mounted instead of the original oil drain screw. Simply remove protecting cap - tighten hose - then the valve opens.



Protecting cap mount - valve closed. Everything without tool. No dirty and burned hands. No oil on the floor. 10637 is a necessary item. And only 1 time mounting. That preserves the thread in the oil pan (those are often no longer supplyable). Completely manufactured in Germany! The thread M16 x 1,5 was installed in: Citroën 2CV, DS, HY, 11CV, GS. Nearly all classical Peugeot (403, 404, 504, 304, 204)

Art.No.	Quality	needed qty
10636	1	1



Hose (25cm) for the oil drain screw with valve (10636). Thread: M22 x 1,5.



Art.No.	Quality	needed qty
10637	1	1



Oil drain screw seal 18 x 24 x 2mm (for M18 thread). Suitable for Peugeot 203, 403, 404, 504, 505, J7 (all engines). Renault R4. Citroën HY. AMI6 with M4 engine. Oil cooler screwed joint 2CV with 16HP!



Art.No.	Quality	needed qty
71066	3	1

16,3 x 22 x 2mm



Gasket for oil drain plug for 2CV6, BX, XM, 204, 203, 304, 404, 504. inlet + exhaust screw, measure: 16,3x22x2mm. Version C, curved with a seal inside. (PTFE)



Art.No.	Quality	needed qty
10001	3	3

Diesel 0,8 Bar



Oil pressure switch (Diesel). Thread M18 x 1,5. Suitable for Peugeot 204D, 304D, 305D, 404D, 504D, 505D, 604D. Citroën HY Diesel. Renault Diesel: R9, R11, R18, R20, R25, R30. Talbot Tagora Diesel. Response pressure: 0,8 bar. Or. No. 1131.10. Due to the design, there is always a drop of oil at the electrical connection. Alternatively, the modern oil pressure switch 70733 can be installed.



Art.No.	Quality	needed qty
71071	3	1

Citroën + Renault



Oil pressure switch, suitable for Citroën ID19, DS19, HY petrol. Citroën 2CV + AMI6 without oil filters! Thread: M14x1,5.



Art.No.	Quality	needed qty
30049	2	1

Renault + Citroën



Oil pressure switch. Thread: M14 x 1,5. Response pressure: 0,5 bar. Suitable for Renault R3 + R4 (747cc), from year of construction 1962 to 1967. Renault Dauphine + Floride. Citroën HY petrol.



Art.No.	Quality	needed qty
81035	3	1



Oil pan sealing set. Suitable for Citroën 11CV D engine + Citroën HY. Or. No. D113-97



Art.No.	Quality	needed qty
60370	3	1

Citroën DS 11CV (11D), ID19, DS19, HY



Oil pan rubber seal (2 fittings), seal to the crankshaft. Suitable for Citroën 11CV D engine, ID19, DS19, HY. Or.Nr. D113-11 + D113-12. Made in Germany.



Art.No.	Quality	needed qty
30316	3	1



Oil pan seal Peugeot Diesel. For the following engines: XD2, XD4.88, XD4.90, XD25, XD3, XD3TE, XDP88, XDP90, CD2P94. Suitable for Peugeot 404, 504, 505, 604, J7, J9. Citroën HY Diesel. Or. No. 0313.23



Art.No.	Quality	needed qty
71290	3	1



Oil pan seal, suitable for Citroën 11CV D + Citroën HY. Or. No. D132-9. Original one of "Glaser".



Art.No.	Quality	needed qty
60371	2	1



Camshaft drive chain duplex, 66 chain links. Suitable for Citroën 11CV, 15CV, ID19, DS19, HY. 1911ccm to year of construction 1966. Original quality!



Art.No.	Quality	needed qty
30046	3	1



Camshaft drive chain tensioner. Suitable for diesel engines: Peugeot 404, 504, 505, J7, J9, Tagora. Citroën HY. Or. No. 0849.04



Art.No.	Quality	needed qty
71038	3	1

Citroën ID19 11CV, HY



Timing chain tensioner, suitable for Citroën ID19. Citroën 11CV + 15CV. Citroën HY. Dimensions: 114x29mm. Or. No. 4612565. But beware: think carefully before installing the chain tensioner. Because the chain will inevitably rub against the chain tensioner (metal on metal = abrasion). We would rather drive without a chain tensioner and replace the timing chain more often.



Art.No.	Quality	needed qty
31214	3	1

Citroën ID19, HY, 11CV D



Spur gear largely. 38 teeth. 27,6mm. Suitable for Citroën 11CV D, starting from year of construction 10/1954. Citroën ID 19 + HY. Or. No. 457347



Art.No.	Quality	needed qty
60914	3	1

Citroën ID19, HY, 11CV



Spur gear small. 19 teeth. Suitable for Citroën 11CV, all years of construction. Citroën ID 19 + HY. Or. No. 461178



Art.No.	Quality	needed qty
60915	3	1



Spur gear set, suitable for Citroën 11D, ID19, DS19, HY. 38 teeth. Or. No. 457347 + 461178



Art.No.	Quality	needed qty
60184	3	1



Valve timing cover - seal (material: Paper). Suitable for Citroën 11CV (D-Engine). Citroën ID19. Citroën HY. Or. No. 451762. Made in Germany.



Art.No.	Quality	needed qty
60558	3	1

Citroën DS + HY 404 + 504



Shaft seal in valve timing cover, suitable for DS + HY. Measurements: 48 x 65 x 10mm.



Art.No.	Quality	needed qty
30341	3	1

0102 engine block

1
2
3
4
5
6
7
8
9
10
11
12
13
14

Peugeot 0942.05



Cam follower (diameter: 24,0mm). Length: 48mm. Suitable for petrol engines: Peugeot 203, Peugeot 403, Peugeot 404, Peugeot 504, Peugeot J7. Diesel engines: Peugeot 404, Peugeot 504, Peugeot J7. Citroën HY. Or. No. 0942.05. Please compare the dimensions!



Art.No.	Quality	needed qty
71031	3	8



Identification plate engine, black. Suitable for Citroën, 2CV (old version), 11CV, HY, DS.

Art.No.	Quality	needed qty
17139	3	1



Identification plate orange, for Citroën. 78x40mm. 2 bores. (Metal). The red identification plates were often used for engine numbers!

Art.No.	Quality	needed qty
16972	3	1



Cam follower, suitable for Citroën DS + HY, from year of construction 6/1956 to 1966. Dimension: 26 x 50 x 14mm. Or. No. DS124-1



Art.No.	Quality	needed qty
30090	3	4



Plug screw for the crankshaft. Suitable for Citroën ID19 + Citroën HY. Thread: M22 x 1.25 x 8. Or. No. DS121-88

Art.No.	Quality	needed qty
30089	3	1



Push rod for inlet + exhaust (6.5 x 242,5mm). Suitable for diesel engines: Peugeot 403D, Peugeot 404D, Peugeot 504D, Peugeot J7D. Citroën HY CD. per piece. Or. No. 0940.08



Art.No.	Quality	needed qty
71033	3	8



Seal, for the water pump, down at the engine block. Suitable for Citroën HY. Diameter: 40mm. Or. No. HY235-30. Made in Germany.

Art.No.	Quality	needed qty
48154	4	1

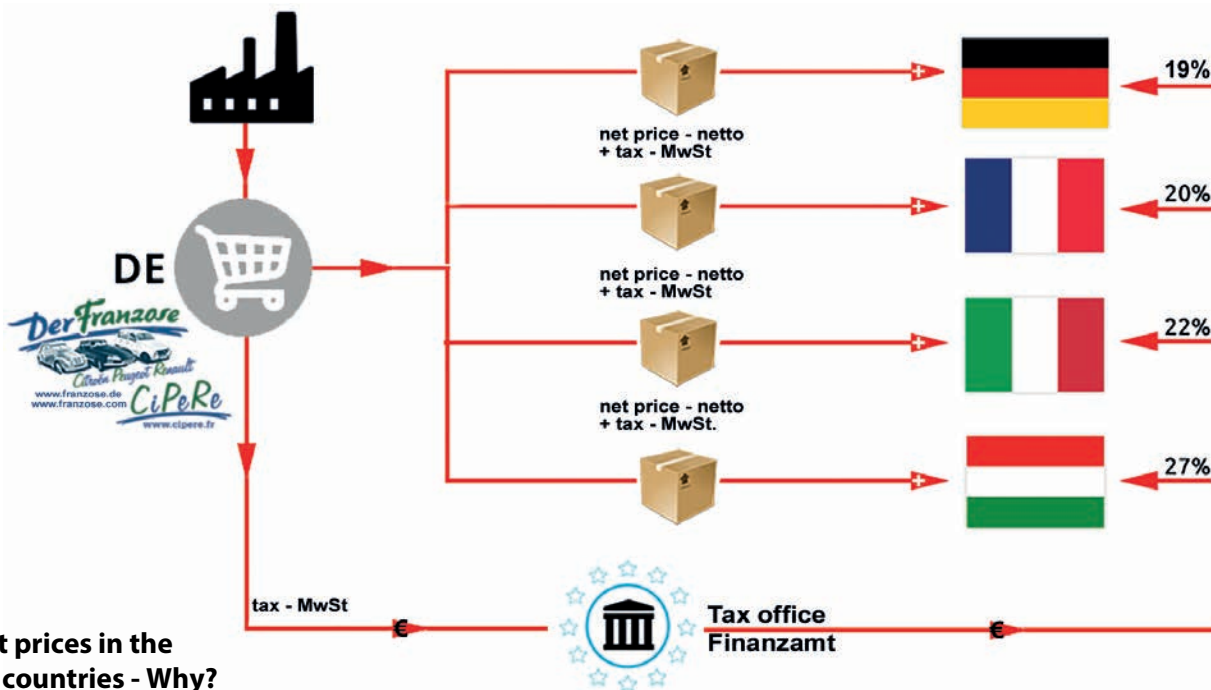

Different prices in the delivery countries - Why?

Since 2021, as an end customer, you will be charged the sales tax rate of the country you have selected for delivery. This Europe-wide regulation has been in force since July 1, 2021, for mail order companies, ensuring a fairer distribution of sales tax revenue across EU countries. (One-Stop-Shop Procedure)

From now on, end customers will be charged the sales tax rate of the country they have selected for delivery. We then pay this tax, one-to-one, back to that country. This means that the sales tax always goes to the country in which the sale actually took place. This change may result in different end consumer prices, as the price calculation is always based on the net price + sales tax (rate of the country of delivery).

Example:

- Delivery country Germany 100€ (net Total) + 19% VAT = 119€ (Gross/end consumer price)
- Delivery country Sweden 100€ (net Total) + 25% VAT = 125€ (Gross/end consumer price)
- Delivery country Ireland 100€ (net Total) + 23% VAT = 123€ (Gross/end consumer price)

More Information: https://ec.europa.eu/taxation_customs/business/vat/telecommunications-broadcasting-electronic-services/content/mini-one-stop-shop_en



Transmission suspension, suitable for Citroën HY. Dimension: 37 - 55.5 - 55mm. Or. No. H133-83



Art.No.	Quality	needed qty
44818	3	1



Safety sheet, for the engine suspension in front. Suitable for Citroën HY. Or. No. ZC9479090U. Made in Germany.



Art.No.	Quality	needed qty
44825	3	1



Keep your oil change labels and record all important information. Protect the labels from dirt and put them in a bag. This way you keep an overview of the work done on the vehicle and you know exactly what maintenance has been done from year to year.

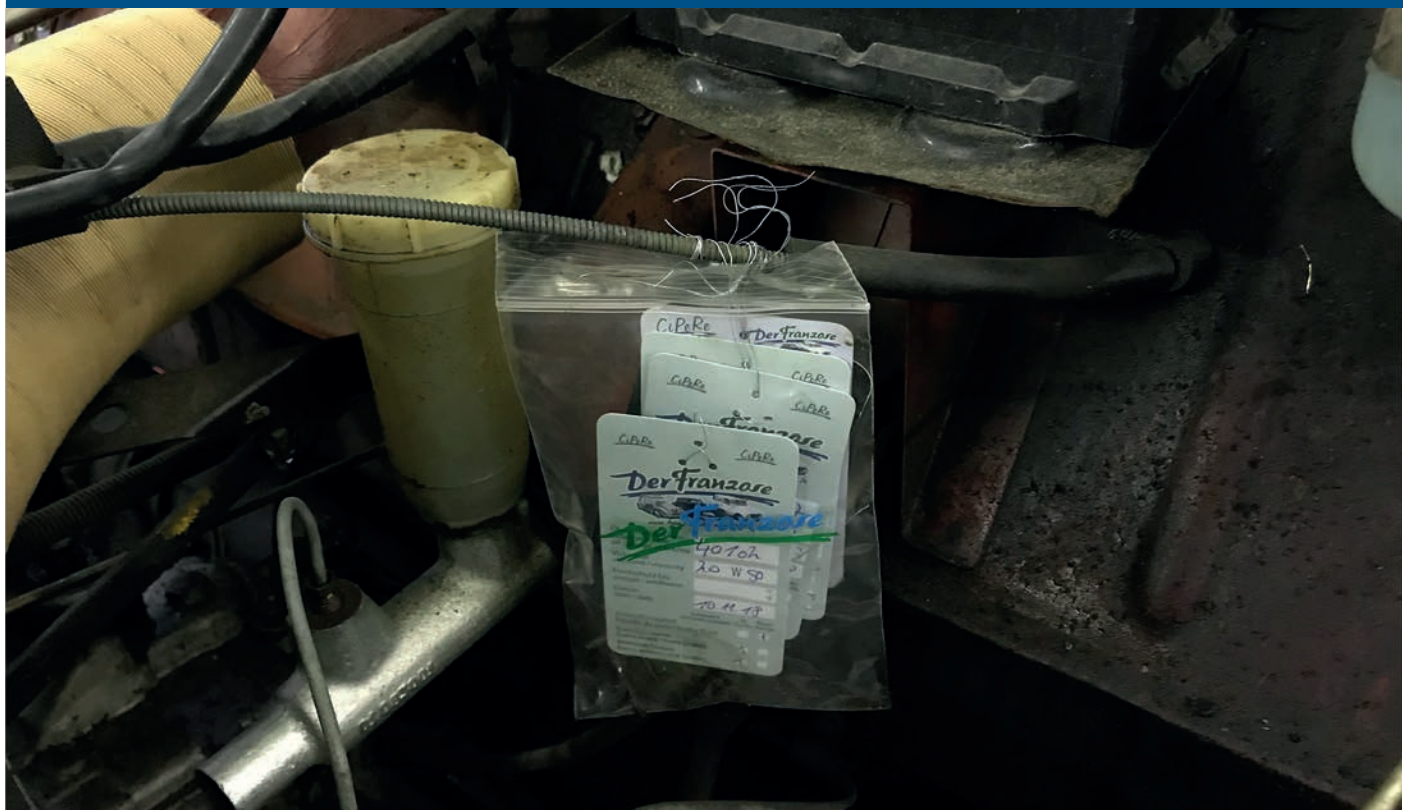

- 1
- 2
- 3
- 4
- 5
- 6
- 7
- 8
- 9
- 10
- 11
- 12
- 13
- 14

0104 Cylinder head

1
2
3
4
5
6
7
8
9
10
11
12
13
14



Sealing rubber (rubber ring) under the valve cap. Seal for the plug body. Suitable for Citroën DS, Citroën HY, Citroën CX.



Art.No.	Quality	needed qty
30021	3	4



Seal between inlet + exhaust elbow + cylinder head. Suitable for Citroën 11CV + Citroën HY to year of construction 1963. 186mm long. Or. Nr.452996



Art.No.	Quality	needed qty
60024	3	2



Exhaust valve, suitable for Citroën 11CV with D-Engine. Citroën HY. Dimension: 33.8 x 9.0 x 110,6mm. Or. Nr.D1248



Art.No.	Quality	needed qty
60019	4	4



Inlet valve, suitable for Citroën 11CV with D-Engine + Citroën HY. Dimension: 37.0 x 9.0 x 108,5mm. Or. Nr.D1247



Art.No.	Quality	needed qty
60020	4	4



Exhaust valve, suitable for Citroën 11CV PERFO engine. Installed from 02/1939 to 05/1955. Citroën HY from 1/1955 to 9/1963. Dimension: 33.8 x 9 x 103mm. Or. No. 461847



Art.No.	Quality	needed qty
60144	3	4



Inlet valve, suitable for Citroën DS, to year of construction 1965. Citroën HY, final models. Diameter: 42mm. Length: 107,7mm. Valve stem: 9mm. Or. No. DS1247



Art.No.	Quality	needed qty
30239	3	4



Exhaust valve, for Citroën DS + HY. Dimension: 39x9x104mm, the valves have 3 grooves for the valve spring cotter at the shank. Or.Nr. DX 124-108 A



Art.No.	Quality	needed qty
30000	3	4



Rocker arm exhaust, suitable for Citroën DS, from year 1965. Citroën HY with aluminum cylinder head. Total length approx. 107mm. Or. No. 1D5412021R + D124-2A



Art.No.	Quality	needed qty
30277	3	4



Exhaust valve, suitable for Citroën DS, to year of construction 1965. Citroën HY, final models. Diameter: 37mm. Length: 105,5mm. Valve stem: 9mm. Or. No. DS1248A



Art.No.	Quality	needed qty
30252	3	4



Rocker arm inlet, suitable for Citroën DS, from year 1965. Citroën HY with aluminum cylinder head. Total length approx. 75mm. Or. No. 1D5412568L + D124-2



Art.No.	Quality	needed qty
30276	3	4



Seal for the cover plate at the cylinder head. Suitable for Citroën 11CV, ID19, DS19, HY. Measurements: 80x71mm. Or.Nr.457469. Made in Germany



Art.No.	Quality	needed qty
30317	3	1



Seal for the cover plate at the cylinder head. Suitable for Citroën DS19, of year of construction 1959 to 1966, Citroën HY. Or.Nr. DM112-88. Made in Germany.



Art.No.	Quality	needed qty
31041	3	1



Seal for the cover plate, at the cylinder head. Suitable for Citroën HY. Or. No. HY11278A



Art.No.	Quality	needed qty
48120	3	1



Rocker arm left (for cylinder 2+4). Suitable for Citroën 11CV D. Citroën HY with cast iron cylinder head.



Art.No.	Quality	needed qty
70724	3	2



Rocker arm right (for cylinder 1+3). Suitable for Citroën 11CV D. Citroën HY with cast iron cylinder head.



Art.No.	Quality	needed qty
70725	3	2



Rocker lever axle, spring for the exhaust rocker arm. Per piece. Suitable for Citroën DS, starting from year of construction 1965 + Citroën HY, starting from year of construction 1967. Dimension: 18.5 x 20.5 x 17mm. Or. No. DD124-80 + 1D 5412571U



Art.No.	Quality	needed qty
30350	3	4



Rocker lever axle, spring for the inlet rocker arm. Per piece. Suitable for Citroën DS, starting from year of construction 1965 + Citroën HY, starting from year of construction 1967. Dimension: 18.3 x 21.3 x 42,5mm. Or. No. DD124-98 + 1D 5412573R



Art.No.	Quality	needed qty
30349	3	4



Rocker arm shaft, for the exhaust valves. Suitable for Citroën HY petrol. Citroën DS19 + ID19. Dimension: 16 x 66mm. Or. No. DS124-21A



Art.No.	Quality	needed qty
48008	3	4



Rocker lever axle, for the inlet valves. Suitable for Citroën HY petrol. Citroën DS19 + ID19. Dimension: 17.95 x 420mm. Or. No. DS124-4



Art.No.	Quality	needed qty
48009	3	1



Manifold seal exhaust (33,4mm inside diameter). Suitable for Citroën DS + Citroën HY. Or. No. DS181-2



Art.No.	Quality	needed qty
32329	3	4



Manifold seal inlet, centrally. Suitable for Citroën DS19, starting from year of construction 7/1959. Citroën HY. Inside diameter: 42mm. Connector long side: 100mm. Connector short side: 61mm. Bore for stud bolts: 8,5mm.



Art.No.	Quality	needed qty
30100	3	1

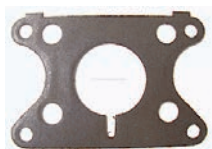

Manifold seal inlet. Suitable for Citroën DS, to year of construction 09/1968. Engine: DY, DL, DLF. Citroën HY. Or. No. DY14111. Inside diameter: 46mm. Connector long side: 105mm. Connector short side: 63mm. Bore for stud bolts: 8,0mm.



Art.No.	Quality	needed qty
30156	3	2



Manifold seal inlet. Suitable for Citroën DS19 + Citroën HY. Or. No. DM141-11. Inside diameter: 45mm. Connector long side: 103mm. Connector short side: 62mm. Bore for stud bolts: 9,0mm.



Art.No.	Quality	needed qty
32315	3	1

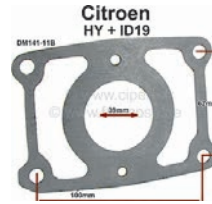

Manifold seal inlet. Suitable for Citroën ID19 + Citroën HY. Or. No. DM141-11B. Inside diameter: 39mm. Connector long side: 100mm. Connector short side: 62mm. Bore for stud bolts: 8,1mm.



Art.No.	Quality	needed qty
48119	3	1



Cap on the valve cap, for filling in engine oil. The cap is supplied with seal + holding rope. Suitable for Citroën DS + Citroën HY.



Art.No.	Quality	needed qty
30233	3	1



Sealing rubber, for the oil filler neck cap. Suitable for Citroën DS, 11CV, HY.



Art.No.	Quality	needed qty
30004	3	1



Rubber cap oil exhausting suitable for the valve cap (crank house exhausting), for Citroën HY + DS early years of construction. Or. No. DS132-48



Art.No.	Quality	needed qty
42342	3	1



Oil exhausting rubber cap, for the valve cap. Suitable for Citroën DS, HY, CX. Inside diameter: 40mm. Inside diameter crank house exhausting: 7,0mm.



Art.No.	Quality	needed qty
30023	3	1



P 403, seal from cork, at the cylinder head. Suitable for Peugeot 403 Diesel + Citroën HY. Engine TMD + XDP85. Or. No. 0147.04



Art.No.	Quality	needed qty
70821	1	1



Ring seal under that bearing block from the inlet rocker arm shaft. Suitable for Citroën DS + Citroën HY. Dimension: Measurements: 8.9 x 14.3 x 2,7mm. Made in Germany.



Art.No.	Quality	needed qty
30241	3	7



Safety sheet, for the rocker arm block. Suitable for Citroën 11CV. Citroën HY, to year of construction 9/1963. Or. No. 463015



Art.No.	Quality	needed qty
60146	3	5

0104 Cylinder head

1
2
3
4
5
6
7
8
9
10
11
12
13
14



Stud bolt M7 on M8. 45mm lengths. Special production!



Art.No.	Quality	needed qty
31219	2	



Stud bolt M8 on M10. 38mm lengths. Special production!



Art.No.	Quality	needed qty
31220	2	



Valve cover gasket from cork. Suitable for Citroën 11CV + Citroën HY, to year of construction 09/1963. Dimension: 44.5 x 15cm. Or. No. 451323



Art.No.	Quality	needed qty
60372	3	1



Valve cover gasket Diesel, suitable for engine XD88, XDP88-BD, XDP88-BDS. 1949cc. Installed from year of construction 1963 to 1975. Suitable for Peugeot 404 D, 504 D, J7 Diesel. Citroën HY Diesel. Or. No. 0249.25



Art.No.	Quality	needed qty
71136	2	1



Valve cover gasket Inedodor Diesel (1816cc). Suitable for Peugeot of 403 + 404 Diesel. Citroën HY Diesel. Installed from year of construction 1959 to 1966. Or. No. 0249.17



Art.No.	Quality	needed qty
71133	2	1



Valve cover gasket, suitable for Citroën DS, starting from year of construction 1965. Citroën HY petrol, starting from year of construction 1969 (final version). Citroën CX (first version).



Art.No.	Quality	needed qty
30022	3	1



Valve cover gasket. Suitable for Citroën DS + HY, to year of construction 7/1961. Citroën 11CV, Citroën U23.



Art.No.	Quality	needed qty
30091	3	1



Valve cover gasket. Suitable for Citroën DS, of year of construction 7/1961 to 1966. Citroën HY. The seal is flat and has a circulating edge! Or. No. DS132-4A



Art.No.	Quality	needed qty
30092	3	1



Valve clearance gauge. 0,05 > 1,00mm. Precision - feeler gauge with conical lamellas



Art.No.	Quality	needed qty
20045	3	1



Valve spring set outside + inside (16 fittings). Suitable for Citroën 11CV PERFO + 11D engine. Citroën HY, to year of construction 9/1963. Or. No. 452914. Dimension: 30 x 46,5mm.



Art.No.	Quality	needed qty
60133	3	1

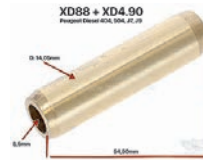

Valve guide inlet + outer valve. Peugeot Diesel XD88 (1948cc) + XD4.90. Suitable for Peugeot 404, 504, J7, J9. Citroën HY Diesel. Inside diameter: 8,5mm. Outside diameter: 14,05mm. Length: 54,50mm.



Art.No.	Quality	needed qty
71272	3	8



Valve guide, for the inlet + the exhaust valve. Suitable for Citroën 11CV + Citroën HY. Dimension: 13 x 55 x 9mm. Or. No. 457358



Art.No.	Quality	needed qty
60138	3	8



Valve adjusting screw (valve clearance). Suitable for Citroën DS + Citroën HY. Thread: M7. Length: 26mm. Or. No. 1D5412567A



Art.No.	Quality	needed qty
30295	3	8



Water pipe (coolant) in the cylinder head. Suitable for Citroën 11CV + U23. Dimension: 422.0 x 20,0mm. Or. No. 451321



Art.No.	Quality	needed qty
60027	4	1



Spark plug thread M14 thread inserts. Suitable for our repair kit 21176. Length of thread inserts: 9.7 mm + 11.0 mm + 13.0 mm + 19.1 mm.



Art.No.	Quality	needed qty
21177	4	1



Spark plug thread M14 cleaner, with a cutter for the spark plug sealing ring. This combination tool can clean your contaminated thread and make it usable again. In addition, the sealing surface around the thread is nicely planed again. But be careful: if the spark plug thread is already badly damaged, you will need to insert a new thread (item 21176).



Art.No.	Quality	needed qty
21178	4	1

Cylinder head 0104



M14
Spark plug thread M14 repair kit (for repairing defective spark plug threads). Hobby quality. For all M14 spark plugs. The repair kit comes with an HSS thread cutter (drive wrench size 17 mm) and 4 thread inserts. Length of thread inserts: 9.7 mm + 11.0 mm + 13.0 mm + 19.1 mm.



Art.No.	Quality	needed qty
21176	4	1



Citroën HY 001982 - 110508
Cylinder head screw (10 x 102mm). Suitable for Citroën 11CV, with Perfo engine. Citroën HY, of year of construction 07/1952 to 11/1958.



Art.No.	Quality	needed qty
60769	3	13



1

2

3

4

5

6

7

8

9

10

11

12

13

14

0105 cylinder head gasket

1
2
3
4
5
6
7
8
9
10
11
12
13
14



Sealing rubber (rubber ring) under the valve cap. Seal for the plug body. Suitable for Citroën DS, Citroën HY, Citroën CX.



Art.No.	Quality	needed qty
30021	3	4



Seal for the cover plate at the cylinder head. Suitable for Citroën DS19, of year of construction 1959 to 1966, Citroën HY. Or.Nr. DM112-88. Made in Germany.



Art.No.	Quality	needed qty
31041	3	1



Valve cover gasket from cork. Suitable for Citroën 11CV + Citroën HY, to year of construction 09/1963. Dimension: 44.5 x 15cm. Or. No. 451323



Art.No.	Quality	needed qty
60372	3	1



Valve cover gasket Diesel, suitable for engine XD88, XDP88-BD, XDP88-BDS. 1949cc. Installed from year of construction 1963 to 1975. Suitable for Peugeot 404 D, 504 D, J7 Diesel. Citroën HY Diesel. Or. No. 0249.25



Art.No.	Quality	needed qty
71136	2	1



Valve cover gasket Indedor Diesel (1816cc). Suitable for Peugeot of 403 + 404 Diesel. Citroën HY Diesel. Installed from year of construction 1959 to 1966. Or. No. 0249.17



Art.No.	Quality	needed qty
71133	2	1



Valve cover gasket, suitable for Citroën DS, starting from year of construction 1965. Citroën HY petrol, starting from year of construction 1969 (final version). Citroën CX (first version).



Art.No.	Quality	needed qty
30022	3	1



Valve cover gasket. Suitable for Citroën DS + HY, to year of construction 7/1961. Citroën 11CV, Citroën U23.



Art.No.	Quality	needed qty
30091	3	1



Valve cover gasket. Suitable for Citroën DS, of year of construction 7/1961 to 1966. Citroën HY. The seal is flat and has a circulating edge! Or. No. DS132-4A



Art.No.	Quality	needed qty
30092	3	1

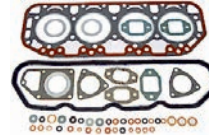

Cylinder head gasket set for Indenor Diesel XDP88. Bore 94mm. Suitable for Citroën HY Diesel + Peugeot 404 D + 504 D. The cylinder head gasket is 1,7mm heavily.



Art.No.	Quality	needed qty
40003	2	1



Cylinder head gasket Indenor Diesel. Engine: XD85. Suitable for Peugeot 403 Diesel, 404 Diesel first years of construction. Citroën HY Diesel. Original manufacturer.



Art.No.	Quality	needed qty
72159	1	1



Cylinder head gasket set for Indenor Diesel. For engine: TMD85, XDP85, TMD85-AD, XPD (1816cc). Suitable for Citroën HY Diesel. Peugeot 403 Diesel, 404 Diesel, 504 Diesel, J7 Diesel. Heavy one: 1,25mm. Or. No. 0199.48



Art.No.	Quality	needed qty
71132	2	1



Cylinder head gasket. Suitable for Citroën HY (petrol engine) from year of construction 09/1963. original Glaser.



Art.No.	Quality	needed qty
48115	2	1

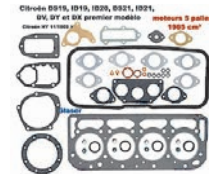

Cylinder head gasket set. Suitable for Citroën ID19, ID20, DS20, DS21, ID21. For engines: DV, DY, DX first version. 1985cc, bore 86mm + 90,0mm. Citroën HY 1,9L, starting from year of construction 11/1969.



Art.No.	Quality	needed qty
30028	3	1

Mountings

The engine and gearbox mountings serve the purpose to absorb the vibrations from the engine. The rubbers of these mountings mature very fast and become too flexible so the vibrations can't be absorbed any longer.

So if your car hums loudly or accelerating makes strange noises, you should check the engine and gearbox mountings. Maybe they are defective. Replacing these parts often works wonders.

Oil Pressure

After a winter break please pull the plus cable out of the ignition coil.

Then let the engine turn a little while until it builds up oil pressure (the oil pressure light disappears). Only now start the engine, your car will be grateful for this.

0105 cylinder head gasket

0 = New old stock
1 = Good
2 = Original
3 = Advanced replica
4 = Replica
5 = Mediocre replica

crankshaft-camshaft-piston-flywheel 0106



Diesel, liner gasket bottom (4x). Suitable for diesel engine: XD85, TMD85, XD88, XDP88, XD4x88, XD90, XD4x90. For the following vehicles: Peugeot 403, 404, 504, J7. Citroën HY Diesel.



Art.No.	Quality	needed qty
71415	3	1



Piston + liner (4 fittings), suitable for Citroën DS - ID19, to year of construction 1965. Citroën HY. Citroën 11CV. Inclusive piston rings. Bore: 78mm. Piston pin: 20,0mm diameter. Curved piston head. Piston rings: 2,5 + 2,5 + 4,5mm.



Art.No.	Quality	needed qty
30273	3	1



Piston + liner (4 pieces), suitable for Citroën DS, to year of construction 1965 (ID19 + DS19). Citroën HY 1911cc (HY78, HW1600, HZ1000, H78). Citroën 11CV D. Bore: 78mm. Flat piston head. Piston pin: 20,0 x 68mm. Piston rings: 2,5 + 2,5 + 3,0 + 3,5mm



Art.No.	Quality	needed qty
30071	3	1



Piston rings (label manufacturer), for 4 pistons. Suitable for Citroën DS19, ID19, to year of construction 01/1962. Citroën HY 1,9L. Citroën 11CV. 78mm bore. Dimension: 2,0 + 2,5 + 4,0 + 4,0mm.



Art.No.	Quality	needed qty
30068	3	1

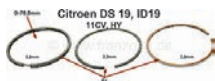

Piston rings (label manufacturer), for 4 pistons. Suitable for Citroën DS19, ID19. Citroën HY 1,9L. Citroën 11CV. 78mm bore. Dimension: 2,0 + 2,5 + 5,0mm.



Art.No.	Quality	needed qty
30066	2	1



Piston ring set, for 4 pistons. Suitable for HY Diesel. Peugeot 404 Diesel. Peugeot 504 Diesels, J7 Diesel. Engine: XD, XDP, TMD4.88. Bore: 88,0mm. Piston rings: 2,0 + 2,0 + 2,0 + 4,5mm.



Art.No.	Quality	needed qty
41022	3	1



Crankshaft bearing (complete set), standard dimension. Suitable for Citroën 11CV with Perfo + D-Engine, of year of construction 1937 to 1957. Citroën U23. Or. No. 45130A



Art.No.	Quality	needed qty
60025	3	1



Crankshaft bearing (complete set). 0.25 oversize. Suitable for Citroën 11CV with Perfo + D-Engine, of year of construction 1937 to 1957. Citroën U23 (van). Made one in France.



Art.No.	Quality	needed qty
60783	3	1



Crankshaft bearing (complete set). Suitable for Citroën DS 19, to year of construction 1965. Citroën HY petrol. Reproduction. Dimension: 0.25 undersize.



Art.No.	Quality	needed qty
30044	3	1



Crankshaft bearing (complete set). Suitable for Citroën DS 19, to year of construction 1965. Citroën HY petrol. Reproduction. Dimension: 0.50 undersize.



Art.No.	Quality	needed qty
30045	3	1



Crankshaft bearing (complete set). Suitable for Citroën DS 19, to year of construction 1965. Citroën HY petrol. Reproduction. Dimension: 0.75 oversize.



Art.No.	Quality	needed qty
30051	3	1



Crankshaft bearing (complete set). Suitable for Citroën DS 19, to year of construction 1965. Citroën HY petrol. Reproduction. Dimension: 1,00 undersize.



Art.No.	Quality	needed qty
30052	3	1



Crankshaft bearing (complete set). Suitable for Citroën DS 19, to year of construction 1965. Citroën HY petrol. Reproduction. Dimension: Standard dimension. 54mm.



Art.No.	Quality	needed qty
30059	3	1



Crankshaft bearing, standard dimension. Suitable for Citroën HY Diesel. Peugeot 403D, 404D, 504D, J7D. Engine: XD/P85 + XDP90 (1816cc + 2112cc).



Art.No.	Quality	needed qty
71159	2	1



Crankshaft bearing, oversize 0,30. Suitable for Citroën HY Diesel. Peugeot 403D, 404D, 504D, J7D. Engine: XD/P85 + XDP90 (1816cc + 2112cc). Dimension: 0,30 (for crankshafts with the measurement of 54.694 to 54,709mm).



Art.No.	Quality	needed qty
71160	2	1

0106 crankshaft-camshaft-piston-flywheel

1
2
3
4
5
6
7
8
9
10
11
12
13
14



Crankshaft bearing, oversize 0,50. Suitable for Citroën HY Diesel. Peugeot 403D, 404D, 504D, J7D. Engine: XD/P85 + XDP90 (1816cc + 2112cc). Dimension: 0,50 (for crankshafts with the measurement of 54.494 to 54,509mm).



Art.No.	Quality	needed qty
71161	2	1



Liner sealing ring down. Suitable for Citroën 11CV, 15CV, ID19, HY. Standard measurement of 0,07mm. Inside diameter: 83,5mm. Outside diameter 95mm. Or. No.: D1113A



Art.No.	Quality	needed qty
60153	3	4



Oil wiper ring, 78mm bore. 4mm thickness. Suitable for Citroën 11CV + HY. Citroën DS, to year of construction 1965. Or. No. D111-11A



Art.No.	Quality	needed qty
60173	3	4



P 403D/404/J7/HY, piston (1 piece), suitable for Citroën HY Diesel. Peugeot 403 D, 404 D, Peugeot J7 Diesel. For engine: XDP 85. Engine capacity: 1816cc. Bore: 85mm.



Art.No.	Quality	needed qty
71318	3	4

XD85, XDP85, TMD85



P 403D/404/J7/HY, liner (1 piece), suitable for Peugeot 403 Diesel, 404 Diesel, Peugeot J7 Diesel. Citroën HY Diesel. For engine: XD85, XDP85, TMD85. Engine capacity: 1816ccm. Bore: 85mm. Dimensions of the liner = outside diameter down: 93mm.



Art.No.	Quality	needed qty
71322	3	4

XD85, XDP85, TMD85



P 403D/404/J7/HY, liner (1 piece), suitable for Peugeot 403 Diesel, 404 Diesel, Peugeot J7 Diesel. Citroën HY Diesel. For engine: XD85, XDP85, TMD85. Engine capacity: 1816ccm. Bore: 85mm. Dimensions of the liner = outside diameter down: 96mm.



Art.No.	Quality	needed qty
71321	3	4



Piston + liner (1 fitting), suitable for Peugeot 404 Diesel, 504 Diesel, Peugeot J7 Diesel. Citroën HY Diesel. For engine: XD8, XDP4/88. Engine capacity: 1948ccm. Bore: 88mm. Piston pin: 28 x 72,0mm. Piston rings: 2,0 - 2,0 - 2,0 - 4,5mm. Dimensions of the liner = outside diameter down: 96mm. Height totally: 173,10mm. Outside diameter above: 106,30mm.



Art.No.	Quality	needed qty
71320	3	4



Piston + liner (4 fittings), suitable for Peugeot of 404 Diesel, 504 Diesel, Peugeot J7 Diesel. Citroën HY Diesel. For engine: XD8, XDP4/88 (1 series). Engine capacity: 1948cc. Bore: 88mm. Piston pin: 28 x 74,40mm. Piston rings: 2,0 - 2,0 - 4,5mm. Dimensions of the liner = outside diameter down: 94mm. Height totally: 173,20mm. Outside diameter above: 104,90mm. Height from downside to bulge (base) of the liner: 129mm.



Art.No.	Quality	needed qty
71319	2	1



Connecting rod bush. Suitable for Citroën 11D, ID19, HY. Dimension: 20 x 21,5 x 25mm. Or. No. D1212C



Art.No.	Quality	needed qty
60175	3	4

Peugeot Diesel



Connecting rod bearing set, 0,30 undersize. Suitable for Citroën HY Diesel. Peugeot 404 Diesel. Peugeot 504 Diesel, J7 Diesel. Engine: XD88, XD2, XD2P94, XD4x88, XD4x90, XD90, XDP4.88, XDP4.90, XDP85, XDP88, XDP90.



Art.No.	Quality	needed qty
41023	3	1

Peugeot Diesel



Connecting rod bearing set, standard dimension. Suitable for Citroën HY Diesel. Peugeot 404 Diesel. Peugeot 504 Diesel, J7 Diesel. Engine: XD88, XD2P94, XD4x88, XD4x90, XD90, XDP4.88, XDP4.90, XDP85, XDP88, XDP90.



Art.No.	Quality	needed qty
41416	3	1



Connecting rod bearing (complete set). Suitable for Citroën ID19, DS19 to year of construction 1965. Citroën HY of 1,9 petrol. Citroën HY of 1,9 petrol. Dimension: 0.25 oversize. For 47,75mm crankshaft. Or. No. DM1219A



Art.No.	Quality	needed qty
30054	3	1



Connecting rod bearing (complete set). Suitable for Citroën ID19, DS19 to year of construction 1965. Citroën HY of 1,9 petrols. Citroën 11CV. Reproduction. Dimension: 0.50 oversize. For 47,50mm crankshaft.



Art.No.	Quality	needed qty
30055	2	1



Connecting rod bearing (complete set). Suitable for Citroën ID19, DS19 to year of construction 1965. Citroën HY of 1,9 petrols. Citroën 11CV. Reproduction. Dimension: 0.75 oversize. For 47,25mm crankshaft.



Art.No.	Quality	needed qty
30056	3	1

crankshaft-camshaft-piston-flywheel 0106



Connecting rod bearing (complete set). Suitable for Citroën ID19, DS19 to year of construction 1965. Citroën HY of 1,9 petrols. Citroën 11CV. Reproduction. Dimension: 1,00 oversize. For 46,00mm crankshaft.



Art.No.	Quality	needed qty
30057	3	1



Connecting rod bearing (complete set). Suitable for Citroën ID19, DS19 to year of construction 1965. Citroën HY of 1,9 petrol. Citroën 11CV. Reproduction. Dimension: Standard dimension. For 48mm crankshaft. Or. No. DM1219



Art.No.	Quality	needed qty
30053	3	1



Connecting rod bearing screw. M 9 x 29mm. Suitable for Citroën 11D. Citroën ID19. Citroën HY. Or. No. DS121-13



Art.No.	Quality	needed qty
60179	3	8



Flywheel screw. M9 x 18mm. Suitable for Citroën 11D, Citroën HY > 06/1962. Citroën DS > 06/1962. Per piece. Or. No. D121-92



Art.No.	Quality	needed qty
60177	3	6



Flywheel bearing, suitable for Citroën 11CV, 15CV, + Citroën HY. Dimension: 17 x 40 x 12mm.



Art.No.	Quality	needed qty
48018	3	1



Camshaft drive chain duplex, 66 chain links. Suitable for Citroën 11CV, 15CV, ID19, DS19, HY. 1911ccm to year of construction 1966. Original quality!



Art.No.	Quality	needed qty
30046	3	1



Camshaft drive chain tensioner. Suitable for diesel engines: Peugeot 404, 504, 505, J7, J9, Tagora. Citroën HY. Or. No. 0849.04



Art.No.	Quality	needed qty
71038	3	1



Timing chain tensioner, suitable for Citroën ID19. Citroën 11CV + 15CV. Citroën HY. Dimensions: 114x29mm. Or. No. 461256S. But beware: think carefully before installing the chain tensioner. Because the chain will inevitably rub against the chain tensioner (metal on metal = abrasion). We would rather drive without a chain tensioner and replace the timing chain more often.



Art.No.	Quality	needed qty
31214	3	1



Spur gear largely. 38 teeth. 27,6mm. Suitable for Citroën 11CV D, starting from year of construction 10/1954. Citroën ID 19 + HY. Or. No. 457347



Art.No.	Quality	needed qty
60914	3	1



Spur gear small. 19 teeth. Suitable for Citroën 11CV, all years of construction. Citroën ID 19 + HY. Or. No. 461178



Art.No.	Quality	needed qty
60915	3	1



Spur gear set, suitable for Citroën 11D, ID19, DS19, HY. 38 teeth. Or. No. 457347 + 461178



Art.No.	Quality	needed qty
60184	3	1



Shaft seal in valve timing cover, suitable for DS + HY. Measurements: 48 x 65 x 10mm.



Art.No.	Quality	needed qty
30341	3	1

Peugeot 0942.05



Cam follower (diameter: 24,0mm). Length: 48mm. Suitable for petrol engines: Peugeot 203, Peugeot 403, Peugeot 404, Peugeot 504, Peugeot J7. Diesel engines: Peugeot 404, Peugeot 504, Peugeot J7. Citroën HY. Or. No. 0942.05. Please compare the dimensions!



Art.No.	Quality	needed qty
71031	3	8



Cam follower, suitable for Citroën DS + HY, from year of construction 6/1956 to 1966. Dimension: 26 x 50 x 14mm. Or. No. DS124-1



Art.No.	Quality	needed qty
30090	3	4



Push rod for inlet + exhaust (6.5 x 242,5mm). Suitable for diesel engines: Peugeot 403D, Peugeot 404D, Peugeot 504D, Peugeot 505D, Peugeot J7D. Citroën HY CD. per piece. Or. No. 0940.08



Art.No.	Quality	needed qty
71033	3	8



Plug screw for the crankshaft. Suitable for Citroën ID19 + Citroën HY. Thread: M22 x 1.25 x 8. Or. No. DS121-



Art.No.	Quality	needed qty
30089	3	1

0107 oil feed + oil cooling + oil filter

1
2
3
4
5
6
7
8
9
10
11
12
13
14

Citroen DS + HY



Hollow bolt for the oil line outside at the engine. Lateral bore: 2,0mm. Suitable for Citroën DS + HY. Or. No. A225-86



Art.No.	Quality	needed qty
30384	3	2

Citroen HY M7



Copper sealing ring doubles, for connector oil line at the engine. Suitable for Citroën HY, ID19. Dimension: 7,2x12mm. Or.Nr.5412173T



Art.No.	Quality	needed qty
48118	3	

14,3x19x1,5



Copper sealing ring, diameter inside 14,3mm. (14,3x19x1,5)



Art.No.	Quality	needed qty
10592	3	

M16 x 1,5



Oil drain screw magnetically, suitable for Citroën 2CV, HY, DS, 11CV (with oil pan out of sheet metal). Interior square. The suitable tool has our number 20221. Or. No. A1321M, thread M16x1,5x20



Art.No.	Quality	needed qty
60123	3	1

M16 x 1,5



Oil drain screw (engine + gearbox) suitable for Citroën 2CV, DS, HY, GS. Thread M16.



Art.No.	Quality	needed qty
10002	4	3

M18 x 1,5



Oil drain screw (engine, Peugeot gearbox, Peugeot rear axle). Thread: M18 x 1,5mm (interior square). Suitable for Peugeot 203, 403, 404, 504, J7. Suitable for all engines. Renault R4. Citroën HY Diesel + AMI6 with M4 engine, AZAM6. Or. No. 0311.07 + 0311.04



Art.No.	Quality	needed qty
71065	3	4

M18 x 1,5



Oil drain screw magnetic (engine, Peugeot gearbox, Peugeot rear axle). Thread: M18 x 1,5mm (interior square). Suitable for Peugeot 203, 403, 404, 504, J7. Suitable for all engines. Renault R4. Citroën HY Diesel + AMI6 with M4 engine, AZAM6



Art.No.	Quality	needed qty
71427	3	4



Oil drain screw with valve. Thread M16 x 1,5. This valve is mounted instead of the original oil drain screw. Simply remove protecting cap - tighten hose - then the valve opens.



Protecting cap mount - valve closed. Everything without tool. No dirty and burned hands. No oil on the floor. 10637 is a necessary item. And only 1 time mounting. That preserves the thread in the oil pan (those are often no longer supplyable). Completely manufactured in Germany! The thread M16 x 1,5 was installed in: Citroën 2CV, DS, HY, 11CV, GS. Nearly all classical Peugeot (403, 404, 504, 304, 204)

Art.No.	Quality	needed qty
10636	1	1



Hose (25cm) for the oil drain screw with valve (10636). Thread: M22 x 1,5.



Art.No.	Quality	needed qty
10637	1	1



Oil drain screw seal 18 x 24 x 2mm (for M18 thread). Suitable for Peugeot 203, 403, 404, 504, 505, J7 (all engines). Renault R4. Citroën HY. AMI6 with M4 engine. Oil cooler screwed joint 2CV with 16HP!



Art.No.	Quality	needed qty
71066	3	1

16,3 x 22 x 2mm



Gasket for oil drain plug for 2CV6, BX, XM, 204, 203, 304, 404, 504. Inlet + exhaust screw, measure: 16,3x22x2mm. Version C, curved with a seal inside. (PTFE)



Art.No.	Quality	needed qty
10001	3	3



Oil pressure switch (Diesel). Thread M18 x 1,5. Suitable for Peugeot 204D, 304D, 305D, 404D, 504D, 505D, 604D. Citroën HY Diesel. Renault Diesel: R9, R11, R18, R20, R25, R30. Talbot Tagora Diesel. Response pressure: 0,8 bar. Or. No. 1131.10. Due to the design, there is always a drop of oil at the electrical connection. Alternatively, the modern oil pressure switch 70733 can be installed.



Art.No.	Quality	needed qty
71071	3	1

Citroën + Renault



Oil pressure switch, suitable for Citroën ID19, DS19, HY petrol. Citroën 2CV + AMI6 without oil filters! Thread: M14x1,5.



Art.No.	Quality	needed qty
30049	2	1

Renault + Citroen



Oil pressure switch. Thread: M14 x 1,5. Response pressure: 0,5 bar. Suitable for Renault R3 + R4 (747cc), from year of construction 1962 to 1967. Renault Dauphine + Floride. Citroën HY petrol.



Art.No.	Quality	needed qty
81035	3	1

oil feed + oil cooling + oil filter 0107



Oil pressure valve spring with sleeve, suitable for Citroën 11CV starting from 1954, Citroën DS first models, HY. The sleeve has 12mm outside diameter and is 20mm long. The spring is 8,5mm x 70mm. Consisting of Or.Nr. DS222-5 + 457381



Art.No.	Quality	needed qty
60804	3	1



Cap on the valve cap, for filling in engine oil. The cap is supplied with seal + holding rope. Suitable for Citroën DS + Citroën HY.



Art.No.	Quality	needed qty
30233	3	1



Sealing rubber, for the oil filler neck cap. Suitable for Citroën DS, 11CV, HY.



Art.No.	Quality	needed qty
30004	3	1



Oil-fill in cap, chromium-plates. Suitable for Citroën 11CV D engine. Citroën HY + Citroën DS19.



Art.No.	Quality	needed qty
60791	3	1



Rubber cap oil exhausting suitable for the valve cap (crank house exhausting), for Citroën HY + DS early years of construction. Or. No. DS132-48



Art.No.	Quality	needed qty
42342	3	1



Oil exhausting rubber cap, for the valve cap. Suitable for Citroën DS, HY, CX. Inside diameter: 40mm. Inside diameter crank house exhausting: 7,0mm.



Art.No.	Quality	needed qty
30023	3	1



Oil filter (like Purflux L126). Suitable for Peugeot 403 Diesel. Peugeot 404 Diesel, to year of construction 09/1969. Citroën HY Diesel. Or. No. 1109.05



Art.No.	Quality	needed qty
70752	3	1



Oil filter LS127. Suitable for Peugeot Diesel + Citroën HY Diesel. Peugeot 204D, starting from year of construction 10/1969. 304D, 403D, 404D starting from year of construction 10/1969, 504 D. Thread: M18x1,5. Or. No. 1109.35



Art.No.	Quality	needed qty
71122	2	1



Tool universal for oil filter, fits for all oil filter, also to remove spheres!



Art.No.	Quality	needed qty
20216	2	1



Oil pump seal. Suitable for Citroën ID19. Citroën 11CV + 15CV. Citroën HY. Or. No. 457220



Art.No.	Quality	needed qty
31216	3	1



Oil pump repair set. Suitable for Citroën 11D. Citroën HY, to year of construction 1963. Citroën DS + ID, to year of construction 03/1963. Dimension: 24.9 x 30mm. Or. No. 457373 + 457374



Art.No.	Quality	needed qty
60191	3	1



Oil pump repair set. Suitable for Citroën HY, starting from year of construction 1963. Both drive wheels have 10 teeth. Or. No. ZC9457373U + ZC9457374U.



Art.No.	Quality	needed qty
48323	3	1



Oil pump grain sieve down. Suitable for Citroën HY, 11CV + 15CV. Dimension: 150 x 10,5mm. Or. No. 452719



Art.No.	Quality	needed qty
60560	3	1



Oil pan sealing set. Suitable for Citroën 11CV D engine + Citroën HY. Or. No. D113-97



Art.No.	Quality	needed qty
60370	3	1



Oil pan rubber seal (2 fittings), seal to the crankshaft. Suitable for Citroën 11CV D engine, ID19, DS19, HY. Or.Nr. D113-11 + D113-12. Made in Germany.



Art.No.	Quality	needed qty
30316	3	1



Oil pan seal, suitable for Citroën 11CV D + Citroën HY. Or. No. D132-9. Original one of "Glaser".



Art.No.	Quality	needed qty
60371	2	1



oil feed + oil cooling + oil filter 0107

0108 engine + transmission oil



Gearbox/transmission oil SAE 75/80,(1 liter, GL4) brand: TOTAL (alternatively from Petronas). This gearbox oil "Transmission Gear8 75W80" made by TOTAL is a formally from Citroën and Peugeot approved oil. This oil is made exclusive and only for use in manual gearboxes, regarding to its high-viscosity it is qualified for very long operation time (until 250000 km). Ideally suitable for all Classic Cars. Depending on the superior viscosity value of 80, shifting for gear change is also in case of low temperatures no problem. We ourselves use this gearbox oil from TOTAL in our complete classic car pool, so as in : R4, DS, ID, 2CV, Dauphine, HY, Fiat 500, Alfa Spider. We are absolutely pleased with this high quality oil, properly for all classic cars.



Art.No.	Quality	needed qty
36107	2	4



Gearbox Oil additive, 20g. Suitable for 1 liter transmission oil. This additive has been specially developed for manual and differential transmissions. The product significantly reduces wear and reduces temperature peaks which means quieter running, softer gear changes and better fuel-efficiency.



Art.No.	Quality	needed qty
20504	1	1



Engine oil HTX 20W-50, from TOTAL/elf. Special oil for classic cars with petrol engine from 1950 ! 5 Litre can. Mineral multi range motor oil for engine technology with oil filter from the fifties on. HTX 20W50 is positioning between soft alloyed one range motor oils and modern lubricants. HTX 20w50 provides motor best armoring for classic engines and warrants optimal oil pressure conditions also at high engine loading level. All seasons motor oil! Rust and corrosion protection for vehicles kept inactive for long periods of time.



Art.No.	Quality	needed qty
20001	1	1



Engine oil Castrol Classic 20W50, filled up in a beautiful sheet metal can. Special oil for classic cars with petrol engine from 1950 ! 5,0 Litre can. Mineral multi range motor oil for engine technology with oil filter from the fifties on. Castrol Classic 20W50 is positioning between soft alloyed one range motor oils and modern lubricants. Castrol Classic 20w50 provides motor best armoring for classic engines and warrants optimal oil pressure conditions also at high engine loading level. All seasons motor oil ! Price per liter: EUR 11,78



Art.No.	Quality	needed qty
20010	2	1



HTX Prestige - Developed for classic cars built between the 1900s and 1950s. 5 Liter tin can. ELF HTX Prestige is for classics from a bygone automotive era. HTX Prestige mineral engine lubricant has a high viscosity to ensure minimal oil loss and Multigrade technology to avoid low-temperature oil circulation issues. The oil is available at SAE 40 grade for vehicles built between 1900 and 1950 without an oil filter or cyclone separator (Citroën 11CV.....) Used oil should be chucked and recycled according to official prescriptions. Please bring used oil to collecting points for used oil recycling.



Art.No.	Quality	needed qty
20015	2	1



Label engine oil "TOTAL". Dimension: 32 x 65mm.



Art.No.	Quality	needed qty
37310	3	1



Oil draining pump 12 Volt. Ideal for emptying the hydraulic tank. For example Citroën DS, CX, GS etc.. Of course other huiles oils can also be pumped with it. Super practical.



Art.No.	Quality	needed qty
20557	3	1



Oil absorbent pad. Extremely absorbent. Dimension: 51x38cm. For oils and brake fluids. Attention, the pads do not suck and absorb water! Your wife will be grateful!



Art.No.	Quality	needed qty
20511	1	1



Oil change card "Der Franzose". With inspection list. Language: German, English, French! Per piece!



Art.No.	Quality	needed qty
10618	1	1



Oil change cards (10 fittings) "Der Franzose". With inspection list. Language: German, English, French!



Art.No.	Quality	needed qty
10619	2	1



Aluminum sealing ring range. 300 sealing rings, from 9x1 to 28x26. Optimally for brake and engine.



Art.No.	Quality	needed qty
21026	3	1



Copper sealing ring range. 150 fittings.



Art.No.	Quality	needed qty
20971	2	1



Citroën HY
502895
ZC9002895U
Differential bearing inside. Suitable for Citroën HY, all years of construction. Dimension: 45 x 85 x 23.



Art.No.	Quality	needed qty
44860	3	2



Citroën DS
Double ball bearing, for the primary shaft rear. Suitable for Citroën DS, with 4 gear gearbox. Dimension: 30 x 72 x 78.6 x 30,2. Or. No. ZC9620164U



Art.No.	Quality	needed qty
31197	2	1



Gearbox sealing ring. Suitable for Citroën HY, starting from year of construction 1974. Citroën DS. Or. No. 22478009K



Art.No.	Quality	needed qty
48108	4	



Gearbox sealing ring. Suitable for Citroën HY, to year of construction 1974. Dimension: 26.0 x 32.0 x 2,5mm. Or. No. 22474009G



Art.No.	Quality	needed qty
48107	4	



Citroën HY
89990 + ZC9088090U
Gearbox bearing for the primary shaft (the rear of the two rear bearings). Suitable for Citroën HY, all years of construction. Dimension: 30 x 62 x 16. Or. No. 89990 + ZC9088 090 U.



Art.No.	Quality	needed qty
44857	3	1



Citroën HY
89981 + ZC9089981U
Gearbox bearing for the primary shaft (the front of the two rear bearings). Suitable for Citroën HY, all years of construction. Dimension: 30 x 62 x 20. Or. No. 89981 + ZC9089 981 U.



Art.No.	Quality	needed qty
44856	3	1



Citroën HY
> 09/1966
507539 + ZC9507539U
Gearbox bearing, for the shaft for the bevel gear. Suitable for Citroën HY, to year of construction 09/1966. Dimensions: 35 x 80 x 21. Attention: This bearing has been reproduced like the original bearing. It is not a standard bearing as it is often offered! Or. No. 507539 + ZC9507 539U. Made in France.



Art.No.	Quality	needed qty
44859	3	1

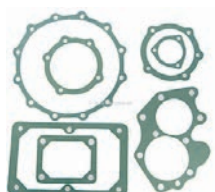

Gearbox sealing set. Suitable for Citroën HY. Or. No. 5456896. Made in Germany.



Art.No.	Quality	needed qty
48121	3	1

Citroën HY
> 09/1966
506287 + ZC9089448U



25 x 62 x 24

Gearbox bearing above (primary shaft). Suitable for Citroën HY, of year of construction 1948 to 09/1966. Dimension: 25 x 62.0 x 24mm. Or. No. 506287 + ZC9089448U



Art.No.	Quality	needed qty
44858	3	1

remaining stock!
while stocks last!



25 x 62 x 67,2 x 25,4
1G 6437164J

Citroën HY
Gearbox bearing on top, front (primary shaft). Suitable for Citroën HY, from year 01/1972. Citroën DS (4 speed gearbox), from year 11/1971. Dimensions: 25 x 62,0 x 67 x 25,4mm. Or. No. 1G 5437164J



Art.No.	Quality	needed qty
48106	3	1

Citroën HY
09/1966>
620010 + ZC960286U



30 x 72 x 78,5 x 30,2

Citroën HY
Gearbox bearing lower (jackshaft). Suitable for Citroën HY, starting from year of construction 09/1966. Dimension: 30 x 72.0 x 78.5 x 30,2mm. Or. No. ZC9620286U + 620010



Art.No.	Quality	needed qty
48112	2	1

Citroën HY
1957 > 08/1966
620071



30 x 72 x 78,5

Citroën HY
Gearbox bearing lower (jackshaft). Suitable for Citroën HY, of year of construction 1957 to 08/1966. Dimension: 30 x 72.0 x 78.5 x 30,0mm. Or. No. 620071



Art.No.	Quality	needed qty
44862	3	1

remaining stock!
while stocks last!



additif pour 1 litre d'huile de Sella
Gearbox oil additive, for 1 liter
Getrieboil Additiv, für 1 Liter

Gearbox Oil additive, 20g. Suitable for 1 liter transmission oil. This additive has been specially developed for manual and differential transmissions. The product significantly reduces wear and reduces temperature peaks which means quieter running, softer gear changes and better fuel-efficiency.



Art.No.	Quality	needed qty
20504	1	1

Citroën DS



30 x 62 x 16mm
ZC9620159

Ball bearing, for primary shaft. Suitable for Citroën DS. Dimension: 30 x 62 x 16mm. Or. No. ZC9620159



Art.No.	Quality	needed qty
31316	3	1

M9 x 42mm



M9, stud bolt, for the mounting of the drive shaft at the gearbox. Suitable for Citroën 2CV + Citroën DS. Measurement: M9x42mm.



Art.No.	Quality	needed qty
12182	3	

0109 transmission



Oil drain screw magnetically, suitable for Citroën 2CV, HY, DS, 11CV (with oil pan out of sheet metal). Interior square. The suitable tool has our number 20221. Or. No. A1321M, thread M16x1,5x20



Art.No.	Quality	needed qty
60123	3	1



Oil drain screw (engine + gearbox) suitable for Citroën 2CV, DS, HY, GS. Thread M16.



Art.No.	Quality	needed qty
10002	4	3



Oil drain screw (engine, Peugeot gearbox, Peugeot rear axle). Thread: M18 x 1,5mm (interior square). Suitable for Peugeot 203, 403, 404, 504, J7. Suitable for all engines. Renault R4. Citroën HY Diesel + AMI6 with M4 engine, AZAM6. Or. No. 0311.07 + 0311.04



Art.No.	Quality	needed qty
71065	3	4



Oil drain screw magnetic (engine, Peugeot gearbox, Peugeot rear axle). Thread: M18 x 1,5mm (interior square). Suitable for Peugeot 203, 403, 404, 504, J7. Suitable for all engines. Renault R4. Citroën HY Diesel + AMI6 with M4 engine, AZAM6



Art.No.	Quality	needed qty
71427	3	4



Gasket for oil drain plug for Citroën 2CV6, BX, XM, 204, 203, 304, 404, 504. inlet + exhaust screw, measure: 16,3x22x2mm. Version C, curved with a seal inside. (PTFE)



Art.No.	Quality	needed qty
10001	3	3



Locking plate, for the drive shaft securement at the gearbox. Suitable for Citroën HY. Or. No. ZC9409506U. Per piece. Made in Germany.



Art.No.	Quality	needed qty
44824	3	6



Shaft seal primary shaft. Suitable for Citroën HY. Dimensions: 21 x 40 x 10mm. Or. No. ZC 9612512U



Art.No.	Quality	needed qty
44922	3	1



Synchronizer, suitable for Citroën HY, starting from year of construction 1967. Citroën ID, starting from year of construction 1964. Or. No. HY335-16



Art.No.	Quality	needed qty
48111	4	



Identification plate green, for Citroën. 78x40mm. 2 bores. (Metal). The green identification plates were often used for gearbox identification!



Art.No.	Quality	needed qty
16973	3	1

0109 transmission

0 = New old stock
 1 = Good
 2 = Original
 3 = Advanced replica
 4 = Replica
 5 = Mediocre replica



Citroën HY



Sealing rubber for the gear shift lever, in the interior. Suitable for Citroën HY. Or. No. HY334-82



Art.No.	Quality	needed qty
48333	3	1

Citroën HY

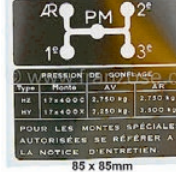

Label, for the gear shift "Gonflage Speciales". Suitable for Citroën HY.



Art.No.	Quality	needed qty
44888	3	1

Citroën HY



Label, for the gear shift "Pressione Gonflage". Suitable for Citroën HY.



Art.No.	Quality	needed qty
44887	3	1

Citroën HY



Label, for the gear shift (in reverse). Suitable for Citroën HY.



Art.No.	Quality	needed qty
44886	3	1

Citroën HY



Label, for the gear shift at the dashboard. Old version. Suitable for Citroën HY.



Art.No.	Quality	needed qty
44889	3	1

Citroën HY

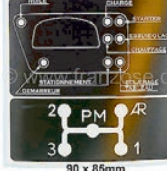

Label, for the gear shift at the dashboard. New version. Suitable for Citroën HY.



Art.No.	Quality	needed qty
44890	3	1



Label, for the gear change lever position. Suitable for Citroën HY.



Art.No.	Quality	needed qty
48235	3	1

FRENCH AUTOMOBILE CULTURE



www.cipere.fr

www.franzose.de

www.franzose.com

0111 differential

1
2
3
4
5
6
7
8
9
10
11
12
13
14



Citroën HY
802895
ZC9502895U

Differential bearing inside. Suitable for Citroën HY, all years of construction. Dimension: 45 x 85 x 23. Or. No. 502895 + ZC9502 895U



Art.No.	Quality	needed qty
44860	3	2



M12x51
www.franzose.de
1D 5423871

Stud bolt for the drive shaft. Dimension: M12x1,25 x 51. Suitable for Citroën DS + Citroën HY. Or. No. 1D5423871



Art.No.	Quality	needed qty
33192	3	12



Citroën DS + HY

Nut, for the connector Tripodes aluminum casing. Suitable for Citroën DS + Citroën HY. Per piece. Dimension: M12 x 1,25 (collar unit). Or. No. ZC9615032U



Art.No.	Quality	needed qty
33191	3	12



Citroën DS + HY

Tripodes case, inclusive new balls. For the securement, of the drive shaft. Suitable for Citroën DS + Citroën HY. Or. No. 2D5430517J



Art.No.	Quality	needed qty
33194	3	2



Shaft seal for the differential (drive shaft). Suitable for Citroën HY + Citroën 15CV. Dimension: 61 x 40 x 12,5mm. Material: Vitton!.. Or. No. ZC96112645U.



Art.No.	Quality	needed qty
44832	1	2

DerFranzose
Citroën Peugeot Renault
www.franzose.com





Label "LHM level", for the LHM reservoir. Dimension: 55 x 85mm.



Art.No.	Quality	needed qty
37312	3	1



Label "LHM". Dimension: 28 x 50mm.



Art.No.	Quality	needed qty
37311	3	1



Label "Maxi - Mini" for the LHM hydraulic reservoir. Suitable for Citroën DS.



Art.No.	Quality	needed qty
37782	3	1



Pressure accumulator ball, LHM, reproduction. 400ccm, 62 bar. Suitable for Citroën ID-DS, BX, GSA, GS, CX, SM.



Art.No.	Quality	needed qty
32103	3	1



Vehicle height corrector repair set. Hydraulic system LHM. Suitable for Citroën DS + HY with hydraulic rear axle. Or. No. DS43502DR



Art.No.	Quality	needed qty
31121	3	2



Vehicle height corrector, in the exchange. Hydraulic system LHM (green liquid). Suitable for Citroën DS + SM. Citroën HY with hydraulic rear axle. Plus 100 Euro Old part deposit.



Art.No.	Quality	needed qty
31124	3	2



Hydraulic pressure controller repair set. System LHM. Suitable for Citroën DS.



Art.No.	Quality	needed qty
31202	3	1



Hydraulic line seal 6,35mm, for LHM (green) hydraulic system. 10mm outside diameter! About 10mm long. Suitable for Citroën DS, CX, GS, SM, BX, XM etc.



Art.No.	Quality	needed qty
32380	3	1



Hydraulic line rubber 6,35mm, LHM (green), 10mm outside diameter! About 8mm long. Suitable for Citroën DS, CX, GS, SM, BX, XM etc.



Art.No.	Quality	needed qty
32154	3	1



Hydraulic line rubber 6,35mm, LHS (red). 10mm outside diameter! Suitable for Citroën DS, with LHS hydraulic system.



Art.No.	Quality	needed qty
32156	3	1



Hydraulic line rubber 6,35mm. LHS (red). 12mm outside diameter. About 10mm long. Only suitable for Citroën DS, with LHS hydraulic system. This heavy rubber is for the connection at the brake system accumulator. Or. No. D392-9020



Art.No.	Quality	needed qty
32276	3	1



Hydraulic pump bearing. Suitable for Citroën DS. Diameter: 50 mm. Inner diameter: 12 mm. Thickness: 16 mm. Or. No. ZC9620073U



Art.No.	Quality	needed qty
30279	3	1

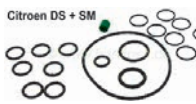

Hydraulic pump sealing set (7 pistons pump). Hydraulic system LHM. Suitable for Citroën DS + SM. For hydraulic pumps with 2 + 3 V-belts.



Art.No.	Quality	needed qty
30370	3	1



Hydraulic pump spring set (15 pieces). Suitable for 7 pistons hydraulic pump, for Citroën DS.



Art.No.	Quality	needed qty
31312	3	1



Spraying varnish 400ml, LHM green. Approximate varnish (RAL 6005). Corresponds rather accurately to the original varnish tone AC502.



Art.No.	Quality	needed qty
39431	3	1



0113 hydraulic fluid + brake fluid

1
2
3
4
5
6
7
8
9
10
11
12
13
14



Label "LHM level", for the LHM reservoir. Dimension: 55 x 85mm.

Art.No.	Quality	needed qty
37312	3	1



Label "LHM". Dimension: 28 x 50mm.

Art.No.	Quality	needed qty
37311	3	1



Label "Maxi - Mini" for the LHM hydraulic reservoir. Suitable for Citroën DS.

Art.No.	Quality	needed qty
37782	3	1



Brake fluid DOT4. 1 liter. Manufacturer ATE. Suitable for all Citroën 2CV to year of construction 1981 (vehicles with drum brake in front). Citroën 11CV, HY. All Peugeot and Renault models.

Art.No.	Quality	needed qty
13026	2	1



Brake fluid DOT4. 1/2 liter. Manufacturer TOTAL. Suitable for all Citroën 2CV to year of construction 1981 (vehicles with drum brake in front). Citroën 11CV, HY. All Peugeot and Renault models.

Art.No.	Quality	needed qty
13244	3	1



Brake fluid DOT4. 5,0 liter can. Manufacturer TOTAL. Suitable for all Citroën 2CV to year of construction 1981 (vehicles with drum brake in front). Citroën 11CV, HY. All Peugeot and Renault models.

Art.No.	Quality	needed qty
13248	3	1



Oil draining pump 12 Volt. Ideal for emptying the hydraulic tank. For example Citroën DS, CX, GS etc.. Of course other huiles oils can also be pumped with it. Super practical.

Art.No.	Quality	needed qty
20557	3	1



0113 hydraulic fluid + brake fluid

0 = New old stock
1 = Good
2 = Original
3 = Advanced replica
4 = Replica
5 = Mediocre replica

2

outside of the engine

intake and exhaust manifold	0201
exhaust system	0202
engine cooling	0203
carburetor + carburetor gasket sets	0204
gas manipulation + gas cable + choke cable	0205
air filter	0206
fuel system (pump, lines, transmitter, tank)	0207
ignition	0208
clutch	0209
clutch cables	0210
generator + spare parts	0211
V-belt	0212
starter	0213
heating + ventilation	0214
engine electric	0215
cooling tube universal	0216

Ethanol fuel

it no longer lives up to expectations

E5 (Super) and E10 petrol is no longer permanently stable when exposed to oxygen and begins to degrade after just a few months. The stabilising additives become ineffective. Many manufacturers therefore only guarantee a shelf life of 60 days.

After that, the fuel begins to separate, resulting in a pungent smell. This means that, as enthusiasts of these vehicles, we must take care of corrosion prevention ourselves. But how, when ethanol is present everywhere?

In higher concentrations, the fuel additive ethanol is a highly effective solvent that severely attacks, amongst other things, seals, fuel lines and other metals used in the fuel system, such as iron, zinc and magnesium. This poses a risk of leaks. Ethanol causes severe corrosion. Furthermore, the fuel system in modern vehicles is a closed system, whereas in classic cars it is constantly in contact with air.

In these open systems, additional corrosion occurs because ethanol is hygroscopic and absorbs moisture from the air. At the same time, as the fuel ages, aggressive acetic and formic acids are produced, which exacerbate the problem. Consequently, the problem of corrosion is exacerbated during prolonged periods of inactivity or due to less frequent refuelling, often resulting from low mileage.

Before vehicles were fitted with catalytic converters, the addition of certain phosphates to petrol helped to counteract corrosion. However, as these damaged the emissions filter (catalytic converter), they were replaced by other agents. With the further development of the automotive industry, these additives eventually disappeared from the fuel. The unleaded petrol of the 1990s offered significantly better corrosion protection than the petrol used in today's fuel systems – which is bad for the fuel tank, carburettor and fuel pump.

Petrol today has a very short shelf life! You should therefore only fill up with petrol without (bio-) ethanol.

To the best of our knowledge (February 2026), Shell V Power 100 contains ether instead of ethanol, according to the manufacturer, and Shell's V-Power contains a maximum of 0.7% ethanol.

For longer periods of inactivity, we recommend adding petrol stabilisers, which are suitable for infrequent drivers and also for the winter break. According to the manufacturer, using this additive eliminates the need to drain the fuel system. We can confirm this from our own experience, but of course cannot guarantee it.

Add the additive to a full tank and let the vehicle run for ten minutes. Nothing more. So far, we have only had positive experiences.



We stock these additives from Liqui Moly under item numbers 20087 and 10617. In practice, the ELF/Total octane booster (item 21174) has also proven very effective.

And even though many 'experts' claim that E10 or E5 petrol is harmless to cars, we do not see it that way. We only follow the advice of many experts to fill the tank to the brim when the car is off the road if you use premium petrol with little or no ethanol.

Another tip that has proven effective for the winter break is adding one per cent of the tank's capacity in the form of synthetic two-stroke oil.

If you own a diesel vehicle, you unfortunately face a problem. In modern diesel fuels (in an open fuel system), bacteria can form that break down the fuel. This mixture then corrodes your injectors and fuel pumps. This often requires very expensive repairs. This is, of course, also a major problem for recreational boating, as these vessels often have Peugeot or Perkins diesel engines fitted.

However, there is an alternative: use HVO fuel. Bacteria cannot form in this fuel.

After refuelling, you should run the engine in to warm it up so that the HVO diesel reaches the fuel system. After switching off, fill the fuel filler neck with HVO using a jerrycan.

And here's a little tip from one bloke to another: we also use premium petrol and petrol additives for our rarely used petrol-powered tools (lawnmowers, chainsaws, etc.). These too start up again without any problems after the winter break.

In short: always buy the best fuel and drive, drive, drive.

Because all classic cars, regardless of the manufacturer, have an open fuel system! This allows oxygen to reach the fuel.

And that's where the dilemma begins...

**result, after 3 years
using fuel with ethanol**

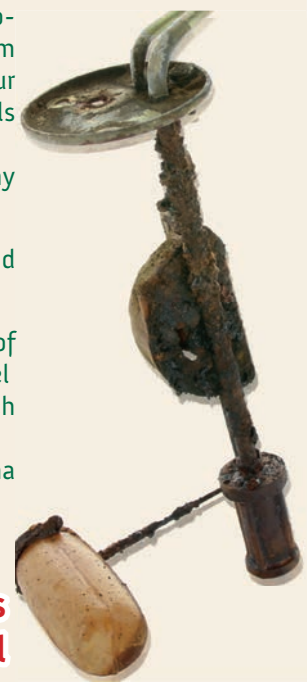

intake and exhaust manifold 0201

Citroën HY 1103



Exhaust elbow, new part. Suitable for Citroën HY, starting from year of construction 1963. Or. No. 5484966



Art.No.	Quality	needed qty
48135	3	1

Citroën DS + HY



Exhaust clip from metal casting (inside diameter 57mm), for the connection exhaust manifold to the flame tube. Suitable for Citroën DS + Citroën HY. Or. No. 5412150T



Art.No.	Quality	needed qty
32352	2	1

Citroën HY 1103
Citroën 11CV



Seal between inlet + exhaust elbow + cylinder head. Suitable for Citroën 11CV + Citroën HY to year of construction 1963. 186mm long. Or. Nr.452996



Art.No.	Quality	needed qty
60024	3	2



Manifold seal exhaust (33,4mm inside diameter). Suitable for Citroën DS + Citroën HY. Or. No. DS181-2



Art.No.	Quality	needed qty
32329	3	4



Manifold seal inlet, centrally. Suitable for Citroën DS19, starting from year of construction 7/1959. Citroën HY. Inside diameter: 42mm. Connector long side: 100mm. Connector short side: 61mm. Bore for stud bolts: 8,5mm.



Art.No.	Quality	needed qty
30100	3	1



Manifold seal inlet. Suitable for Citroën DS, to year of construction 09/1968. Engine: DY, DL, DLF. Citroën HY. Or. No. DY14111. Inside diameter: 46mm. Connector long side: 105mm. Connector short side: 63mm. Bore for stud bolts: 8,0mm.



Art.No.	Quality	needed qty
30156	3	2

Citroën DS19 + HY



Manifold seal inlet. Suitable for Citroën DS19 + Citroën HY. Or. No. DM141-11. Inside diameter: 45mm. Connector long side: 103mm. Connector short side: 62mm. Bore for stud bolts: 9,0mm.



Art.No.	Quality	needed qty
32315	3	1

Citroën HY + ID19



Manifold seal inlet. Suitable for Citroën ID19 + Citroën HY. Or. No. DM141-11B. Inside diameter: 39mm. Connector long side: 100mm. Connector short side: 62mm. Bore for stud bolts: 8,1mm.



Art.No.	Quality	needed qty
48119	3	1

M7



copper nut M7 for exhaust system ! For exhaust system and outlet manifold. Please use only copper nuts: no rust, no sticking!



Art.No.	Quality	needed qty
20139	2	

M8



M8, copper nut M8, for 13mm tool. Universal suitable e.g. for exhausts + exhaust manifolds.



Art.No.	Quality	needed qty
60129	3	1

M8



M8, copper nut, for 12mm open end wrench. For exhausts + exhaust manifolds.



Art.No.	Quality	needed qty
31213	3	

M8



M8, nut for 12mm wrench. (Metal) (e.g. carburetor on intake manifold 2CV).



Art.No.	Quality	needed qty
10112	3	



Nut (toggle), for the securement of the elbow. Suitable for Citroën 11CV with Perfo + D-Engine. Citroën HY, to year of construction 1963. Or. Nr.451331



Art.No.	Quality	needed qty
60028	3	1



P 504/505/J7/HY, exhaust elbow seal, suitable for Indenor Diesel XDP88. Bore 94mm. Suitable for Citroën HY Diesel. Peugeot 504D, 505D, J7D, J9D. Inside diameter: 40 x 30mm. Bore diameter: 9mm. Bore distance from center to center: 64mm.



Art.No.	Quality	needed qty
40006	2	4



P 504/505/J7/HY, intake manifold seal for Indenor Diesel XDP88. Bore 94mm. Suitable for Citroën HY Diesel. Peugeot 504D, 505D, J7D, J9D.



Art.No.	Quality	needed qty
40005	2	4

M7 **M8**



Stud bolt M7 on M8. 45mm lengths. Special production!



Art.No.	Quality	needed qty
31219	2	

M7x28



M7, stud bolt M7x28. (e.g. screening plate on manifold Citroën DS). Or. No. ZC9616135W



Art.No.	Quality	needed qty
31206	3	3

0201 intake and exhaust manifold



M7x43
Stud bolt M7x43mm (thread M7x1). This stud bolt are installed, for example, at the exhaust elbow with Citroën 15CV. Elbow pipe Citroën DS, etc. Universally fitting!



Art.No.	Quality	needed qty
60200	3	13



M8x50
Stud bolt M8x50, cylinder head exhaust elbow. Suitable for Citroën DS + HY. Original Citroën!



Art.No.	Quality	needed qty
31218	2	

stud bolt M8x55



Stud bolt M8 on M10. 38mm lengths. Special production!



Art.No.	Quality	needed qty
31220	2	



Art.No.	Quality	needed qty
30300	3	



stud bolt M8x35



Art.No.	Quality	needed qty
30088	3	1



stud bolt M8x62



Art.No.	Quality	needed qty
30391	3	



Stud bolt M8x45, e.g. elbow securement Citroën DS.



Art.No.	Quality	needed qty
30078	3	



	38mm Tailpipe trim chromium-plates. 38mm inside diameter. Universal suitable. Reproduction of the typical trim from the fifties + sixties.							
<table border="1"><tr><th>Art.No.</th><th>Quality</th><th>needed qty</th></tr><tr><td>72195</td><td>3</td><td>1</td></tr></table>	Art.No.	Quality	needed qty	72195	3	1		
Art.No.	Quality	needed qty						
72195	3	1						
	Citroën HY 09/1963 > 1981 Exhaust silencer fixture on the left. Suitable for Citroën HY, starting from year of construction 09/1963. Or. No. HY183-91							
<table border="1"><tr><th>Art.No.</th><th>Quality</th><th>needed qty</th></tr><tr><td>44909</td><td>3</td><td>1</td></tr></table>	Art.No.	Quality	needed qty	44909	3	1		
Art.No.	Quality	needed qty						
44909	3	1						
	Citroën HY 09/1967 > 1981 Exhaust silencer fixture on the right. Suitable for Citroën HY, starting from year of construction 09/1967. Or. No. HY182-66							
<table border="1"><tr><th>Art.No.</th><th>Quality</th><th>needed qty</th></tr><tr><td>44910</td><td>3</td><td>1</td></tr></table>	Art.No.	Quality	needed qty	44910	3	1		
Art.No.	Quality	needed qty						
44910	3	1						
	Citroën HY > 09/1967 Exhaust silencer fixture on the right. Suitable for Citroën HY, to year of construction 09/1967. Or. No. HY182-100							
<table border="1"><tr><th>Art.No.</th><th>Quality</th><th>needed qty</th></tr><tr><td>44912</td><td>3</td><td>1</td></tr></table>	Art.No.	Quality	needed qty	44912	3	1		
Art.No.	Quality	needed qty						
44912	3	1						
	Citroën HY 1949 + 1963 Exhaust silencer. Suitable for Citroën HY (type H), of year of construction 1949 to 1963. Or. No. H183-01 + HY183-0a							
<table border="1"><tr><th>Art.No.</th><th>Quality</th><th>needed qty</th></tr><tr><td>42349</td><td>3</td><td>1</td></tr></table>	Art.No.	Quality	needed qty	42349	3	1		
Art.No.	Quality	needed qty						
42349	3	1						
	Citroën HY 1963 + 1969 Exhaust silencer. Suitable for Citroën HY petrol, of year of construction 1963 to 10/1969. Or. No. HY182-0							
<table border="1"><tr><th>Art.No.</th><th>Quality</th><th>needed qty</th></tr><tr><td>42343</td><td>3</td><td>1</td></tr></table>	Art.No.	Quality	needed qty	42343	3	1		
Art.No.	Quality	needed qty						
42343	3	1						
	Citroën HY Indenor Diesel 1969 + 1981 Exhaust silencer. Suitable for Citroën HY Indenor Diesel, starting from year of construction 11/1969. Or. No. HG182-901a							
<table border="1"><tr><th>Art.No.</th><th>Quality</th><th>needed qty</th></tr><tr><td>42347</td><td>3</td><td>1</td></tr></table>	Art.No.	Quality	needed qty	42347	3	1		
Art.No.	Quality	needed qty						
42347	3	1						
	Citroën HY Indenor Diesel 1964 + 1969 Exhaust silencer. Suitable for Citroën HY Indenor Diesel, of year of construction 1964 to 10/1969. Or. No. HG183-0b							
<table border="1"><tr><th>Art.No.</th><th>Quality</th><th>needed qty</th></tr><tr><td>42346</td><td>3</td><td>1</td></tr></table>	Art.No.	Quality	needed qty	42346	3	1		
Art.No.	Quality	needed qty						
42346	3	1						
	Citroën HY 1969 + 1981 Exhaust silencer. Suitable for Citroën HY, starting from year of construction 11/1969. Or. No. HY182-901A. Simple reproduction. Very simply built from the inside.							
<table border="1"><tr><th>Art.No.</th><th>Quality</th><th>needed qty</th></tr><tr><td>42200</td><td>4</td><td>1</td></tr></table>	Art.No.	Quality	needed qty	42200	4	1		
Art.No.	Quality	needed qty						
42200	4	1						

	Citroën HY 11/1969 > 1981 Exhaust silencer. Suitable for Citroën HY, starting from year of construction 11/1969. Or. No. HY182-901A. Good reproduction. Very complex exhaust system and absorption inside.							
<table border="1"><tr><th>Art.No.</th><th>Quality</th><th>needed qty</th></tr><tr><td>44880</td><td>3</td><td>1</td></tr></table>	Art.No.	Quality	needed qty	44880	3	1		
Art.No.	Quality	needed qty						
44880	3	1						
	Citroën U23 + T23 Exhaust silencer. Suitable for Citroën U23 + T23. Inlet pipe "short" inside diameter: 49,0mm. Outlet pipe "long" outside diameters: 38,0mm.							
<table border="1"><tr><th>Art.No.</th><th>Quality</th><th>needed qty</th></tr><tr><td>42350</td><td>3</td><td>1</td></tr></table>	Art.No.	Quality	needed qty	42350	3	1		
Art.No.	Quality	needed qty						
42350	3	1						
	200g Exhaust sealing compound 200g. For sealing larger holes, gaps, cracks. Relatively tough material. It hardens!							
<table border="1"><tr><th>Art.No.</th><th>Quality</th><th>needed qty</th></tr><tr><td>20483</td><td>3</td><td>1</td></tr></table>	Art.No.	Quality	needed qty	20483	3	1		
Art.No.	Quality	needed qty						
20483	3	1						
	Exhaust seal triangular. Suitable for Citroën 11CV + Citroën HY to year of construction 9/1963. Or. No. 308324							
<table border="1"><tr><th>Art.No.</th><th>Quality</th><th>needed qty</th></tr><tr><td>60176</td><td>3</td><td>1</td></tr></table>	Art.No.	Quality	needed qty	60176	3	1		
Art.No.	Quality	needed qty						
60176	3	1						
	Exhaust seal oval, suitable for Citroën 11CV + Citroën HY, to year of construction 1963. Inside diameter. about 41mm. Bore diameter: 10mm. Bore difference from center to center: about 68mm. Or. No. 308431							
<table border="1"><tr><th>Art.No.</th><th>Quality</th><th>needed qty</th></tr><tr><td>60181</td><td>3</td><td>2</td></tr></table>	Art.No.	Quality	needed qty	60181	3	2		
Art.No.	Quality	needed qty						
60181	3	2						
	150g Exhaust assembly paste 150g. For sealing the plug-in connections when mounting exhaust pipes. The compound hardens when heated. Very helpful!							
<table border="1"><tr><th>Art.No.</th><th>Quality</th><th>needed qty</th></tr><tr><td>20485</td><td>3</td><td>1</td></tr></table>	Art.No.	Quality	needed qty	20485	3	1		
Art.No.	Quality	needed qty						
20485	3	1						
	Citroën 2CV, Dyane, Mehari, DS Exhaust pipe securement. Rubber, short version. Suitable for Citroën DS + HY. Or. No. DS18280. Per piece.							
<table border="1"><tr><th>Art.No.</th><th>Quality</th><th>needed qty</th></tr><tr><td>31015</td><td>4</td><td>2</td></tr></table>	Art.No.	Quality	needed qty	31015	4	2		
Art.No.	Quality	needed qty						
31015	4	2						
	Citroën HY 1969 + 1981 Tail pipe for the exhaust. Suitable for Citroën HY, starting from year of construction 1963. For fuel engine, Diesel Perkins. Or. No. HY182-4							
<table border="1"><tr><th>Art.No.</th><th>Quality</th><th>needed qty</th></tr><tr><td>42202</td><td>4</td><td>1</td></tr></table>	Art.No.	Quality	needed qty	42202	4	1		
Art.No.	Quality	needed qty						
42202	4	1						

1
2
3
4
5
6
7
8
9
10
11
12
13
14

0202 exhaust system

1
2
3
4
5
6
7
8
9
10
11
12
13
14



Exhaust pipe centrally, between front mufflers + tail pipe. Suitable for Citroën HY Inenor Diesel, starting from year of construction 11/1969. Or. No. HG182-204a



Art.No.	Quality	needed qty
42348	3	1



Exhaust pipe centrally, between front mufflers + tail pipe. Suitable for Citroën HY, starting from year of construction 11/1969. Or. No. HY182204A.



Art.No.	Quality	needed qty
42201	4	1



Exhaust pipe link (tubing adapter). Inside diameter 42,5mm. Length: 130mm



Art.No.	Quality	needed qty
21069	3	1



Exhaust pipe in front (between exhaust manifold + silencer). Suitable for Citroën U23 + T23.



Art.No.	Quality	needed qty
42351	3	1



Exhaust pipe in front, between exhaust manifolds and silencers. Suitable for Citroën HY, starting from year of construction 1963 to production end. Engine: Fuel. OR. No. HY182-1



Art.No.	Quality	needed qty
42203	4	1



Exhaust pipe seal, suitable for Citroën HY Diesel + Peugeot J7. Engine: XDP88, XDP90, XDPX90 (1948cc + 2112cc + 2304cc). Inside diameter: 47,0mm. Outside diameter: 66,0mm. Or. No. 171007 + 171078



Art.No.	Quality	needed qty
40008	3	1



Exhaust pipe seal, suitable for Citroën HY Diesel. Engine XDP88. Bore 94mm.



Art.No.	Quality	needed qty
40007	3	1



Exhaust pipe seal. Suitable for Citroën HY Diesel (XDP88). Peugeot 504 2.3D (XD2). Peugeot J7 (XDP88, XDP4.88, XDP90, XDPX90). Inside diameter: 46mm. Outside diameter: 60mm with 2 slots! Or. No. 171019



Art.No.	Quality	needed qty
40009	3	1



Exhaust clip 49mm. Suitable for Citroën HY, with Indenor Diesel.



Art.No.	Quality	needed qty
42359	3	1



Exhaust clip 53mm.



Art.No.	Quality	needed qty
42354	3	1



Exhaust clip 66mm.



Art.No.	Quality	needed qty
42355	3	1



Exhaust clip 38mm (clamp clip). Thread: M8



Art.No.	Quality	needed qty
42353	3	1



Exhaust clip 42mm (clamp clip).



Art.No.	Quality	needed qty
42356	3	1



Exhaust clip 52mm (clamp clip). Thread: M10!



Art.No.	Quality	needed qty
42357	3	1



Exhaust clip 54mm (clamp clip). Thread: M8



Art.No.	Quality	needed qty
42352	3	1



Exhaust clip 56mm (clamp clip). Thread: M8



Art.No.	Quality	needed qty
42358	3	1



Exhaust clip from metal casting (inside diameter 57mm), for the connection exhaust manifold to the flame tube. Suitable for Citroën DS + Citroën HY. Or. No. 5412150T



Art.No.	Quality	needed qty
32352	2	1



Exhaust clip, suitable for Citroën HY, starting from year of construction 1969. This clip is mounted between manifold + first exhaust pipe + securement tail pipe. Or. No. 541215



Art.No.	Quality	needed qty
42205	3	2



Rubber silent block M10. Diameter: 40mm. Overall height: 28mm. Suitable for Renault R16 and many different.



Art.No.	Quality	needed qty
82825	3	2



Silent block M6. Amount: 25mm. Suitable for exhaust Renault R4, R5, R6. Citroën DS front muffler. Universal



Art.No.	Quality	needed qty
82020	3	1



Silent block M8. Diameter: 40mm. Overall height: about 28mm. Thread: M8



Art.No.	Quality	needed qty
82990	3	1



copper nut M7 for exhaust system ! For exhaust system and outlet manifold. Please use only copper nuts: no rust, no sticking!



Art.No.	Quality	needed qty
20139	2	



M8, copper nut M8, for 13mm tool. Universal suitable e.g. for exhausts + exhaust manifolds.



Art.No.	Quality	needed qty
60129	3	1



M8, copper nut, for 12mm open end wrench. For exhausts + exhaust manifolds.



Art.No.	Quality	needed qty
31213	3	



M8, nut for 12mm wrench. (Metal) (e.g. carburetor on intake manifold 2CV).



Art.No.	Quality	needed qty
10112	3	



Metal sleeve for the rubber strips, with which the exhaust pipes are fastened. Suitable for Citroën DS, 11CV, HY.



Art.No.	Quality	needed qty
32369	3	4



0203 engine cooling

1
2
3
4
5
6
7
8
9
10
11
12
13
14



Label coolant "TOTAL".
Dimension: 31 x 62mm.



Art.No.	Quality	needed qty
37313	3	1



Bush (mounting for the axle) in the water pump housing. Suitable for Citroën 11CV + HY. Dimension: 15 x 19 x 32mm. Or. No. 32935



Art.No.	Quality	needed qty
60491	3	1



Distilled water, 5 liters. For radiator filling. Tap water contains harmful components for the cooling circuit. For mixing the antifreeze fluid, please take care to use distilled water. It improves the adhesion of corrosion-blocker in your cooling system.



Art.No.	Quality	needed qty
20556	3	1



GLACELF CARTECH antifreeze concentrate from Total (must be mixed with distilled water). Suitable for classic engines that also have aluminium and/or copper components (radiator, cylinder head, etc.). Reliable protection against rust, corrosion, foaming and cavitation. Mixing ratio: 50% antifreeze + 50% distilled water. Attention: This is a new antifreeze from TOTAL that replaces the antifreeze "GLACEELF Auto Supra" (GLACELF contains borates, which are no longer permitted in the EU). The two antifreezes can be mixed together. But be careful: CARTECH antifreeze is only mixable with GLACELF Auto Supra from TOTAL. CARTECH is not mixable with antifreeze from other manufacturers. But it is best to replace the antifreeze completely with TOTAL CARTECH! General information: Amines, nitrites and borates are no longer allowed under the new EU CLP regulations. In addition, 2-ethylhexanoic acids must be removed because they are suspected of being harmful to human reproduction (or in short: it making you impotent!)



Art.No.	Quality	needed qty
21157	2	4



Antifreeze Coolant Tester Dial Type



Art.No.	Quality	needed qty
20093	3	1



Rubber (seal) down at the water pump. Transition to the water pipe at the cylinder head. Suitable for Citroën HY, starting from year of construction 09/1963. Or. No. ZC9472409U



Art.No.	Quality	needed qty
48150	3	1



Radiator (in the exchange), suitable for Citroën HY petrol, starting from year of construction 1966. Made in Germany. The radiator is completely dismantled and cleaned. Radiator glass blasting, radiator core renew, radiators checked for tightness and radiators completely painted. Plus 250 Euro Old part deposit.



Art.No.	Quality	needed qty
48139	3	1



Radiator (in the exchange), suitable for Citroën HY petrol, to year of construction 1958. Made in Germany. The radiator is completely dismantled and cleaned. Radiator glass blasting, radiator core renew, radiators checked for tightness and radiators completely painted. Plus 250 Euro Old part deposit.



Art.No.	Quality	needed qty
48339	3	1



Radiator (in the exchange), suitable for Citroën HY, from year of construction 1963 to 1966. Made in Germany. The radiator is completely dismantled and cleaned. Radiator glass blasting, radiator core renew, radiators checked for tightness and radiators completely painted. Plus 250 Euro Old part deposit.



Art.No.	Quality	needed qty
48338	3	1



Radiator drain valve (tap), completely fabricated from brass. Thread: M14 x 1,5mm



Art.No.	Quality	needed qty
32482	3	1



Degreaser for radiator. For cleaning and degreasing of copper and aluminium radiators. Use: mix 1 kg degreaser in 10 liters warm water. After draining of cooling water fill in radiator with degreasing water: After driving (1-2 days) please drain degreasing water and flush the cooling system with hot water before refilling it. Caution: the cleaning process may uncover some leakages!



Art.No.	Quality	needed qty
52209	1	1



Descaling agent for radiators. For decalcifying of copper and aluminium radiators. Use: mix 1 kg softening agent in 10 liters warm water. After Draining of cooling water fill in radiator with decalcifying: After driving (1-2 days) please drain softening agent water and flush the cooling system with hot water before refilling it. Caution: the cleaning process may uncover some leakages!



Art.No.	Quality	needed qty
52208	1	1



Radiator Fin Straightener.
Designed for straightening fins and removing debris from vehicles radiators and air conditioning condensers. One tool with 6 different combs works on any vent or grill. The use of this tool allows the radiator or air conditioning grill to work correctly. Also use on air conditioning grills. Also suitable for oil and water radiators/condensers and evaporators



Art.No.	Quality	needed qty
21039	1	1

Citroën 11CV
HY > 1963



Radiator cap from brass.
Suitable for Citroën 11CV + Citroën HY, to year of construction 1963. Or. Nr.329627



Art.No.	Quality	needed qty
60039	4	1

Citroën 11CV, HY
Peugeot 203, 403



Radiator cap chromium-plates, with seal. For 60mm thread diameter. Suitable for Citroën 11CV, HY, Peugeot 203 + 403



Art.No.	Quality	needed qty
60818	3	1



Radiator cap, for Peugeot Diesels + Citroën HY Diesel.
Suitable for Peugeot 204 D, 304 D, 404 D, 504 D, 505 D, 604 D. diameters: 56mm. Pressure disk diameter: 39mm.



Art.No.	Quality	needed qty
72583	3	1

Citroën DS
0.28 bar



Radiator cap, suitable for Citroën DS, to year of construction 07/1972 + HY (petrol) starting from year of construction 1963. 0.28 atue. All Citroën DS, without radiator expansions tank. Cap internal dimension = 57mm. The sealing rubber has a diameter of 38mm. Above in the cap is no seal. (all vehicles without compensating tank do not have above in the cap a seal. All vehicles with expansion tank have a seal). Or. No. 5418102N



Art.No.	Quality	needed qty
32251	3	1



Radiator hose (water hose) on the left. Suitable for Citroën HY, all years of construction. Connection: both sides 40,0mm. Or. No. H235-3B



Art.No.	Quality	needed qty
48155	4	1

Citroën HY Diesel



Radiator hose above (on the radiator). Suitable for Citroën HY Diesel. 40mm/53mm. Or. No. HG 235-3



Art.No.	Quality	needed qty
48335	3	1

Citroën HY



Coolant hose above, curved around 90° (with external connection). Altogether 3 connections. Outside diameter: 50+50+25 mm. Suitable for Citroën HY, starting from year of construction 09/1963. Or. No. HY23510A



Art.No.	Quality	needed qty
48152	3	1

Citroën HY 1963 >



Radiator hose above. Suitable for Citroën HY, starting from year of construction 1963. Connection diameter: 60,0 + 40,0mm, outside diameter: 70,0 + 50,0mm. Or. Nr.HY2353



Art.No.	Quality	needed qty
60014	3	1

Citroën HY



Coolant hose on the right, suitable for Citroën HY, all years of construction. Overall length about 340mm. 40mm connection. Or.Nr. H2351



Art.No.	Quality	needed qty
48151	3	1

Citroën HY



Radiator hose connecting piece, under the water pump (connection at the engine block). Suitable for Citroën HY. Or. No. HY235-87



Art.No.	Quality	needed qty
48156	3	1



Radiator hose universal. Inside diameter: 10,0mm. Outside diameter: 17,0mm. Length: 1000mm.



Art.No.	Quality	needed qty
72263	3	1



Radiator hose universal. Inside diameter: 12,0-13,0mm. Outside diameter: 19,0-22,0mm. Length: 1000mm.



Art.No.	Quality	needed qty
72264	3	1



Radiator hose universal. Inside diameter: 15,0mm. Outside diameter: 22,0mm. Length: 1000mm.



Art.No.	Quality	needed qty
72265	3	1



Radiator hose universal. Inside diameter: 18,0mm. Outside diameter: 25,0mm. Length: 1000mm.



Art.No.	Quality	needed qty
72266	3	1



Radiator hose universal. Inside diameter: 22,0mm. Outside diameter: 29,0mm. Length: 1000mm.



Art.No.	Quality	needed qty
72267	3	1

0203 engine cooling

1
2
3
4
5
6
7
8
9
10
11
12
13
14



Radiator hose universal. Inside diameter: 25,4mm. Outside diameter: 32,0mm. Length: 1000mm.

Art.No.	Quality	needed qty
72268	3	1



Radiator hose universal. Inside diameter: 8,0mm. Outside diameter: 15,0mm. Length: 1000mm.

Art.No.	Quality	needed qty
72262	3	1



Coolant hose down, curved around 90°. Suitable for Citroën HY, starting from year of construction 09/1963. Connection diameter: about 37mm. Outside diameter: 50mm Or. No. HY23511A

Art.No.	Quality	needed qty
48153	3	1



Radiator hose down, suitable for Citroën HY Indenor Diesel. Inside diameter: 38, mm on the side with one connection. 43,0 + 15,5mm on the other side. Or. No. HG235-1

Art.No.	Quality	needed qty
48282	3	1



P 404/HY, water pump. Suitable for Peugeot 404 Diesel. Citroën HY Diesel. Engine XD88. Installed from year of construction 1960 to 1975. Or. No. 1202.44 + 1202.90

Art.No.	Quality	needed qty
72033	3	1



P 404/HY, water pump seal. Suitable for Peugeot 404 Diesel. Citroën HY Diesel. Engine XD88. Installed from year of construction 1960 to 1975. Or. No. 1206.07. Made in Germany.

Art.No.	Quality	needed qty
72404	3	1



Tube bending sleeve. Suitable for hose outer diameter of 12,5 > 13,4mm. Length: 60mm. With this you can easily produce bent water hoses. Simple and ingenious!

Art.No.	Quality	needed qty
72539	1	1



Tube bending sleeve. Suitable for hose outer diameter of 14,6 > 16,4mm. Length: 65mm. With this you can easily produce bent water hoses. Simple and ingenious!

Art.No.	Quality	needed qty
72540	1	1



Tube bending sleeve. Suitable for hose outer diameter of 16,5 > 18,4mm. Length: 70mm. With this you can easily produce bent water hoses. Simple and ingenious!

Art.No.	Quality	needed qty
72541	1	1



Tube bending sleeve. Suitable for hose outer diameter of 18,8 > 21mm. Length: 75mm. With this you can easily produce bent water hoses. Simple and ingenious!

Art.No.	Quality	needed qty
72542	1	1



Tube bending sleeve. Suitable for hose outer diameter of 21,8 > 24mm. Length: 90mm. With this you can easily produce bent water hoses. Simple and ingenious!

Art.No.	Quality	needed qty
72543	1	1



Hose clamp 11-17mm, especially for radiator hose. Vintage look. Embossed band with raised edges. This prevents the hose from being damaged. Small screw housing with 7mm hexagon head screw (with slot). Normal, modern hose clamps squeeze the hose. This is completely avoided with these clamps. And they even look better.

Art.No.	Quality	needed qty
50216	1	1



Hose clamp 13-20mm, especially for radiator hose. Vintage look. Embossed band with raised edges. This prevents the hose from being damaged. Small screw housing with 7mm hexagon head screw (with slot). Normal, modern hose clamps squeeze the hose. This is completely avoided with these clamps. And they even look better.

Art.No.	Quality	needed qty
50217	1	1



Hose clamp 15-24mm, especially for radiator hose. Vintage look. Embossed band with raised edges. This prevents the hose from being damaged. Small screw housing with 7mm hexagon head screw (with slot). Normal, modern hose clamps squeeze the hose. This is completely avoided with these clamps. And they even look better.

Art.No.	Quality	needed qty
50218	1	1





19-28mm

Hose clamp 19-28mm, especially for radiator hose. Vintage look. Embossed band with raised edges. This prevents the hose from being damaged. Small screw housing with 7mm hexagon head screw (with slot). Normal, modern hose clamps squeeze the hose. This is completely avoided with these clamps. And they even look better.



Art.No.	Quality	needed qty
50219	1	



40-56mm

Hose clamp 40-56mm, especially for radiator hose. Vintage look. Embossed band with raised edges. This prevents the hose from being damaged. Small screw housing with 7mm hexagon head screw (with slot). Normal, modern hose clamps squeeze the hose. This is completely avoided with these clamps. And they even look better.



Art.No.	Quality	needed qty
50224	1	



22-32mm

Hose clamp 22-32mm, especially for radiator hose. Vintage look. Embossed band with raised edges. This prevents the hose from being damaged. Small screw housing with 7mm hexagon head screw (with slot). Normal, modern hose clamps squeeze the hose. This is completely avoided with these clamps. And they even look better.



Art.No.	Quality	needed qty
50220	1	



50-65mm

Hose clamp 50-65mm, especially for radiator hose. Vintage look. Embossed band with raised edges. This prevents the hose from being damaged. Small screw housing with 7mm hexagon head screw (with slot). Normal, modern hose clamps squeeze the hose. This is completely avoided with these clamps. And they even look better.



Art.No.	Quality	needed qty
50225	1	



26-38mm

Hose clamp 26-38mm, especially for radiator hose. Vintage look. Embossed band with raised edges. This prevents the hose from being damaged. Small screw housing with 7mm hexagon head screw (with slot). Normal, modern hose clamps squeeze the hose. This is completely avoided with these clamps. And they even look better.



Art.No.	Quality	needed qty
50221	1	



57-75mm

Hose clamp 57-75mm, especially for radiator hose. Vintage look. Embossed band with raised edges. This prevents the hose from being damaged. Small screw housing with 7mm hexagon head screw (with slot). Normal, modern hose clamps squeeze the hose. This is completely avoided with these clamps. And they even look better.



Art.No.	Quality	needed qty
50226	1	



32-44mm

Hose clamp 32-44mm, especially for radiator hose. Vintage look. Embossed band with raised edges. This prevents the hose from being damaged. Small screw housing with 7mm hexagon head screw (with slot). Normal, modern hose clamps squeeze the hose. This is completely avoided with these clamps. And they even look better.



Art.No.	Quality	needed qty
50222	1	



15 - 20mm

hose clamp for 15-20mm.



Art.No.	Quality	needed qty
51020	3	



40 - 60mm

hose clamp for 40-60mm.



Art.No.	Quality	needed qty
51013	3	



38-50mm

Hose clamp 38-50mm, especially for radiator hose. Vintage look. Embossed band with raised edges. This prevents the hose from being damaged. Small screw housing with 7mm hexagon head screw (with slot). Normal, modern hose clamps squeeze the hose. This is completely avoided with these clamps. And they even look better.



Art.No.	Quality	needed qty
50223	1	



Hose clamp Screwdriver hexagon (7mm). Flexible. Ideal for our hose clamps with raised edges.



Art.No.	Quality	needed qty
50227	1	

 Citroën HY
11CV + 15CV

Shaft seal for the water pump. Suitable for Citroën 11CV/15CV + HY. Outside diameter: 35mm. Inside diameter: 15mm. Height charges: 13mm. Height unloaded: 17mm. Or. No. 456399



Art.No.	Quality	needed qty
60366	3	1

0203 engine cooling

1
2
3
4
5
6
7
8
9
10
11
12
13
14



Peugeot Diesel
XD88, XD90, XD2, XD3
Citroën HY Diesel

Temperature switch coolant.
88°-75°. Thread: M22x1,5.
Suitable for Peugeot diesel
engines, XD88, XD90, XD2 XD3
(Peugeot 404, 505, 604, Citroën
HY).

Art.No.	Quality	needed qty
72051	2	1



72°

Thermostat 72°, suitable for
Citroën DS. Citroën HY. Peugeot
203, 403, 404, 504. Mounting in
the radiator hose. Opening
temperature 72°. Or. No.
DS234-01A

Art.No.	Quality	needed qty
32323	2	1



75° Diesel

Thermostat 75°. Diesel. Suitable
for Peugeot 404 all Diesel, J7 D,
J9 D. Citroën HY Diesel. Engine:
XD85, XD88, XDP88.

Art.No.	Quality	needed qty
72043	3	1



75°

Thermostat 75°C. Installed in
the radiator hose. Suitable for
Citroën DS + HY. Peugeot 203,
403, 404, 504 (to year of
construction 1978). Or. No.
Citroën: DS23401A. Or. No.
Peugeot: 133726

Art.No.	Quality	needed qty
34509	3	1



77°

Thermostat 77°, suitable for
Citroën DS. Citroën HY. Peugeot
203, 403, 404, 504. Mounting in
the radiator hose. Opening
temperature 77°. Or. No.
5430115

Art.No.	Quality	needed qty
32324	2	1



Universal radiator hose 90°
sheet. Inside diameter: 15,0 >
16,0mm. Outside diameter:
25mm. Leg length 130 +
100mm.

Art.No.	Quality	needed qty
72348	3	1



10mm

End cap rubber. 10mm inside
diameter. E.G., for plugging
water pumps or heater radiator
connections.

Art.No.	Quality	needed qty
32446	3	1



12mm

End cap rubber. 12mm inside
diameter. E.G., for plugging
water pumps or heater radiator
connections.

Art.No.	Quality	needed qty
32447	3	1



14mm

End cap rubber. 14mm inside
diameter. E.G., for plugging
water pumps or heater radiator
connections.

Art.No.	Quality	needed qty
32448	3	1



16mm

End cap rubber. 16mm inside
diameter. E.G., for plugging
water pumps or heater radiator
connections.

Art.No.	Quality	needed qty
32449	3	1



18mm

End cap rubber. 18mm inside
diameter. E.G., for plugging
water pumps or heater radiator
connections.

Art.No.	Quality	needed qty
32450	3	1



21mm

End cap rubber. 21mm inside
diameter. E.G., for plugging
water pumps or heater radiator
connections.

Art.No.	Quality	needed qty
32451	3	1



23mm

End cap rubber. 23mm inside
diameter. E.G., for plugging
water pumps or heater radiator
connections.

Art.No.	Quality	needed qty
32452	3	1



26mm

End cap rubber. 26mm inside
diameter. E.G., for plugging
water pumps or heater radiator
connections.

Art.No.	Quality	needed qty
32453	3	1



8mm

End cap rubber. 8mm inside
diameter. E.G., for plugging
water pumps or heater radiator
connections.

Art.No.	Quality	needed qty
32445	3	1



Citroën HY
1963>

Water pump (new part) for
Citroën HY, Installed starting
from year of construction
7/1963. Or. No.5443099V. A old
part return is not necessary!
Caution: The HY has an open
cooling system. It is essential to check if the
radiator cap is the right one ! The water pump can
evacuate some cooling water through a small
opening. New water pumps need approx. 500 km
to 1000 km to get at 99,5 % leakproof. It is just
normal to see some drops of water on the water
pump!

Art.No.	Quality	needed qty
48336	3	1



Citroën HY 09/1963 - 09/1963
Citroën U23



Water pump (new part) HY 9/50 till 9/63, U23. Or.Nr. 456815. Caution: The HY has an open cooling system. It is essential to check if the radiator cap is the right one! The water pump can evacuate some cooling water through a small opening. New water pumps need approx. 500 km to 1000 km to get at 99,5 % leakproof. It is just normal to see some drops of water on the water pump!



Art.No.	Quality	needed qty
48142	3	1

Citroën HY



Seal, for the water pump, down at the engine block. Suitable for Citroën HY. Diameter: 40mm. Or. No. HY235-30. Made in Germany.



Art.No.	Quality	needed qty
48154	4	1

Peugeot + Citroën Diesel 1960



Water pump, suitable for Citroën HY Diesel. Peugeot 505 Diesel, Peugeot J7 Diesel. Possibly the two small connections must be plugged. Or. No. 120187, 120295, 120291, 120288, 120299. Hose flange diameter: 1x 16mm, 1x 55mm, 1x 42mm.



Art.No.	Quality	needed qty
42314	3	1

Citroën HY 09/63 >



Water pump axle, suitable for Citroën HY, starting from year of construction 9/1963. Dimension: 15 x 158mm. Or. No. HY2313



Art.No.	Quality	needed qty
48145	3	1



Water pump axle, suitable for Citroën HY, to year of construction 09/1963. Dimension: 15 x 170mm.



Art.No.	Quality	needed qty
48149	3	1

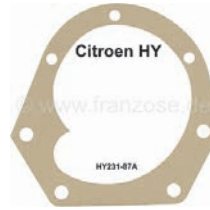

Water pump seal largely. Suitable for Citroën HY. Or. No. HY23187A. Made in Germany.



Art.No.	Quality	needed qty
48147	3	1



Water pump seal small. Suitable for Citroën HY, starting from year of construction 09/1963. Or. No. HY23188A. Made in Germany.



Art.No.	Quality	needed qty
48148	3	1



Water pump seal small. Suitable for Citroën U23 + HY to year of construction 9/1963. Or. No. 451631. Made in Germany.



Art.No.	Quality	needed qty
48140	3	1



Water pipe (coolant) in the cylinder head. Suitable for Citroën 11CV + U23. Dimension: 422.0 x 20,0mm. Or. No. 451321



Art.No.	Quality	needed qty
60027	4	1



0204 carburetor + carburetor gasket sets

1



SOLEX
CO adjusting screw, M 5x0,75 mm, (idle mixture adjusting screw), for Solex carburetor. Suitable for Citroën 2CV (round carburetor). Citroën 11CV, HY, DS. Renault 4CV, Dauphine, R4, Caravelle, Floride. Peugeot 203, 403, 404, 504.



Art.No.	Quality	needed qty
82681	3	1

2



CO tester (exhaust tester). Digitally. Optimally for the experienced mechanic, in order to adjust the carburetor. We use it since years for our classic cars! English operating instructions are attached. For the language German, Dutch, Spanish, Italian, French can be down-load the operating instructions of our homepage.



Art.No.	Quality	needed qty
20505	3	1

3

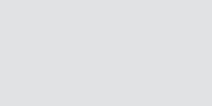

Seal under carburetor oval (2 fittings). Suitable for Citroën ID19, HY, 11CV. Peugeot. Inside diameter: 34mm. Spacer bolt center to spacer bolt center: about 61mm. Or. No. 481717. This seal fits almost to all Solex 34 carburetors.



Art.No.	Quality	needed qty
60384	3	2

4



0,45mm > 1,5mm
Nozzle gauge from 0.45 to 1.5 mm. 20 nozzle gauges. With these nozzle gauges, you can determine the diameter of carburetor nozzles. Indispensable for work on the carburetor (e.g. changing the nozzle to original values, calibrating the carburetor, etc.).



Art.No.	Quality	needed qty
10914	3	1

5



Solex
30/32/34 PICS-PCIS
Float from copper, in the carburetor, for Solex carburetor 30/32/34-PICS/PCIS. Diameter above: 37mm, down: 25mm, float height: 27mm. Installed one e.g. in 2CV4+6, Peugeot, Dauphine etc.



Art.No.	Quality	needed qty
10402	4	1

7



Solex PBICA
Carburetor sealing set, for Solex PBICA. Suitable for Citroën 2CV, DS, 11CV, HY. Peugeot 403, 404, 504 L, J7. Renault Dauphine + Floride. The diaphragm has a diameter of 20mm.



Art.No.	Quality	needed qty
32057	3	1

9



Citroen
Carburetor ring spanner, for the 12mm nut. Suitable for Citroën 11CV, HY, DS



Art.No.	Quality	needed qty
31319	3	1

11



Solex 34 PBICA
Carburetor sealing set small, Solex PBICA. Suitable for Peugeot 203, 403, 404. Citroën 11CV, HY, DS (early years of construction).



Art.No.	Quality	needed qty
72782	3	1

12

13



outil de nettoyage des gicleurs de carburateur
Carburetor jet cleaning tool
Vergrößerter Reinigungsstrahl
Carburetor jet cleaning tool. Essential for carburetor maintenance and cleaning in your classic car. The scope of delivery includes five stainless steel nylon brushes with diameters of 2, 3, 4, 5 and 7 mm and a brush length of 30 mm. Ten stainless steel cleaning needles with diameters of 0.7, 0.9, 1.1, 1.3 and 1.4 mm. A 4 mm Allen key and twelve round carbon steel files with diameters of 0.4, 0.5, 0.6, 0.7, 0.8, 0.9, 1.0, 1.1, 1.2, 1.3, 1.4 and 1.6 mm. A flat file is also included.



Art.No.	Quality	needed qty
10915	3	1



Seal under carburetor oval (2 fittings). Suitable for Citroën ID19, HY, 11CV. Peugeot. Inside diameter: 34mm. Spacer bolt center to spacer bolt center: about 61mm. Or. No. 481717. This seal fits almost to all Solex 34 carburetors.



Art.No.	Quality	needed qty
60384	3	2



14

gas manipulation + gas cable + choke cable 0205

Citroën
2CV, HY, 11CV

Choke cable "S" first version for Citroën 2CV + Ami6. Also suitable for Citroën 11CV + Citroën HY. Length: 1000mm.



Art.No.	Quality	needed qty
10635	3	1

Citroën 11CV + 15CV
07/1952 -

Choke cable with oval knob. Suitable for Citroën 11CV/15CV, starting from year of construction 07/1952. Length: 810mm. This choke cable can be installed also universal. Or. No. 723171



Art.No.	Quality	needed qty
60442	3	1

Citroën
2CV + HY

Throttle linkage clip, suitable for Citroën 2CV + HY. Only for vehicles with throttle linkage, not for 2CV6 with throttle control cable! Or. No. AM124-121. Note: There is also the clip 10588. Those is curved 180° differently around.



Art.No.	Quality	needed qty
10690	4	1



Throttle linkage clip, suitable for Citroën 2CV + HY. Only for vehicles with throttle linkage, not 2CV6 with throttle control cable! Or.Nr. AZ124121. Note: There is also the clip 10690. Those is curved 180° differently around.



Art.No.	Quality	needed qty
10588	4	1



Foot throttle spring, suitable for Citroën HY, starting from year of construction 03/1963. Or. No. H142-14A



Art.No.	Quality	needed qty
48239	3	1



Foot throttle spring, suitable for Citroën HY, of year of construction 05/1959 to 03/1963. Or. No. H142-14.



Art.No.	Quality	needed qty
48238	3	1



Knob "S" for choke cable. Suitable for Citroën 11CV, 15CV, 2CV old, HY. The handle is oval and from aluminum.



Art.No.	Quality	needed qty
60809	3	1



0206 air filter

1
2
3
4
5
6
7
8
9
10
11
12
13
14



Label "MIOFILTRE" for the air filter. Suitable for Citroën 2CV from the fifties, 11CV, HY.

Art.No.	Quality	needed qty
16906	3	1



Air filter label. Reproduction of the original label (gold colored, red frame). This label was mounted on many air filters. Citroën DS to year of construction 1965, 2CV, HY, Renault, Simca, Peugeot.

Art.No.	Quality	needed qty
32060	3	1



Butterfly nut for the cap of the sheet metal air filter. Suitable for Citroën 2CV + HY. Or. No. AM 171-123

Art.No.	Quality	needed qty
10470	4	1



Air filter label. Reproduction of the original label. Suitable for Citroën DS + HY.

Art.No.	Quality	needed qty
38255	3	1



Air cleaner element (spare type). Suitable for Citroën HY, starting from year of construction 9/1963. Citroën ID19, of year of construction 1957 to 1962. 268mm lengthens. Outside diameter 115mm, inside diameter 83mm.

Art.No.	Quality	needed qty
48401	3	1

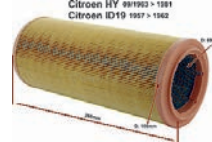

Air cleaner element (spare type). Suitable for Citroën HY, starting from year of construction 9/1963. Citroën ID19, of year of construction 1957 to 1962. 268mm lengthens. Outside diameter 108mm, inside diameter 69mm.

Art.No.	Quality	needed qty
48028	3	1

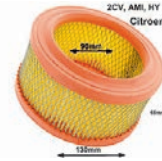

Air filter element for 2CV from the sixties, AMI for sheet metal air filter, HY Diesel + Citroën HY petrol to year of construction 1963 (H171-0A). Outside diameter: 130mm. Inside diameter: 90mm. Height of 60-65mm

Art.No.	Quality	needed qty
10499	2	1



Air cleaner element suitable for Citroën AMI6, AMI8, Mehari + Citroën HY Diesel. Outside diameter: 118mm. Inside diameter: 75mm. Height: 88mm. Or.Nr.: AM1715

Art.No.	Quality	needed qty
10217	2	1



Air filter oil 0.5 liters. To apply on wire and foam material air filters. (These air filters must be sprayed with oil, because they have then only the correct filter performance).

Art.No.	Quality	needed qty
72982	3	1



fuel system (pump, lines, transmitter, tank, tank cap) 0207



Gasoline filter made of metal chromium-plates. The filter has a inspection window. Gasoline line connection 5-6mm. Universal fitting.

Art.No.	Quality	needed qty
10071	3	1



Gasoline filter largely. Universal suitable for Renault, Peugeot, Citroën HY, DS etc.

Art.No.	Quality	needed qty
82643	3	1



Gasoline filter universal, from plastic. Universal fitting, e.g. for 2CV, DS, 11CV, HY, Peugeot, Renault, Simca.

Art.No.	Quality	needed qty
10070	2	1



Gasoline filter with check valve (membrane) preventing gasoline from flowing back again, universal model. Better start after long immobilisation time. The membrane of the fuel pump does not run dry quickly. Indispensable for vintage cars. For fuel hose with 5,5 - 7,5 mm internal diameter. Diameter 34mm. Construction length totally 100mm.

Art.No.	Quality	needed qty
10613	1	1



Fuel filter universal, slim and long. Length: 142mm. Diameter maximally: 37mm.

Art.No.	Quality	needed qty
30362	3	1



Gasoline filter universal. Metal chromium-plates, with control glass. For fuel hose with 8,0-9,5mm inside diameter.

Art.No.	Quality	needed qty
82650	1	1



Fuel pipe from cupro-nickel alloy. Outside diameter 7,95mm, length 5000mm. Suitable for Renault R4, R5 and many further vehicles.

Art.No.	Quality	needed qty
82915	3	1



Gasoline line set, suitable for Citroën HY + 11CV. Consisting of: 5 meters copper nickel gasoline line (rigid). 2 meters metal encased fuel hose. 1x fuel prefilter with return stop + 6 x clip.

Art.No.	Quality	needed qty
60913	3	1



Citroën DS 1966 > 1975
Gasoline pump distance plate. Suitable for Citroën DS, starting from year of construction 1966. Or. No. DX173-98. Made in Germany

Art.No.	Quality	needed qty
32387	3	1



Citroën DS 1968 > 1975
Citroën HY
Fuel pump made entirely of metal. The pump is operated by a tappet. Suitable for Citroën DS, built between 1968 and 1975. Citroën HY 1968>. The pump is of very high quality. Item no. 5447891. Made in the EU.

Art.No.	Quality	needed qty
32332	3	1



Citroën DS
Gasoline pump completely made of metal. Long operating lever (about 43mm). Suitable for Citroën ID/DS, starting from year of construction 1955 to 1965. Citroën HY 1911ccm, Installed from year of construction 1948 to 1967. Citroën 11CV (Traction Avant), from year of construction 1934 to 1957. The gasoline pump has additionally a manual operating lever! Connections in + out = 6mm. The pump is very high-quality. Made in European Union.

Art.No.	Quality	needed qty
32353	3	1



Citroën 11CV + 15CV
Gasoline pump mechanically, with inspection glass + hand lever. Suitable for Citroën 11CV, 15CV, ID19, HY. Or. No. 595822A

Art.No.	Quality	needed qty
60017	4	1



Citroën DS 1968 > 1975
HY 1968 >
Gasoline pump, with short operating lever. Suitable for Citroën DS, starting from year of construction 1968 to 1975. Citroën HY. Manufacturer: Valeo. Or. No. 5447891

Art.No.	Quality	needed qty
30202	2	1



GUIOT
Citroën 11CV, 15CV, ID19, HY
Gasoline pump (GUIOT) repair set. Suitable for Citroën 11CV, 15CV. Citroën ID19 + HY. Diameter diaphragm: 93,0mm. Or. No. 586877. Made in Germany.

Art.No.	Quality	needed qty
60400	3	1



Citroën HY, ID19, 11CV
Renault 4CV, Dauphine, R4
Peugeot 203, 403
SEV
Gasoline pump (SEV) repair set. Diaphragm diameter: 102mm. Suitable for Citroën 11CV, 15CV. Citroën HY, ID19. Renault Dauphine, 4CV, R4. Peugeot 203 + 403. Please observe the diameter! Made in Germany.

Art.No.	Quality	needed qty
60404	3	1

- 1
- 2
- 3
- 4
- 5
- 6
- 7
- 8
- 9
- 10
- 11
- 12
- 13
- 14

0207 fuel system (pump, lines, transmitter, tank, tank cap)

1
2
3
4
5
6
7
8
9
10
11
12
13
14



Gasoline pump cap seal, for mechanical SEV gasoline pumps. Dimension: 65 x 73 x 3mm. Partly suitable for Citroën 11CV, 15CV. Citroën HY. Renault 4CV + Dauphine. Renault 203 + 403. Made in Germany.



Art.No.	Quality	needed qty
60402	3	1



Gasoline pump glass cover (prefilter), for GUIOT gasoline pump. Diameter: 45mm. Suitable for Citroën 11CV, 15CV + Citroën HY. Or. No. 595335



Art.No.	Quality	needed qty
60409	3	1

Citroën HY + 11CV



Gasoline pump glass cover (prefilter), for SEV gasoline pump. Suitable for Citroën 11CV, 15CV + Citroën HY.



Art.No.	Quality	needed qty
60458	3	1



Gasoline pumps repair set, only for SEV gasoline pumps. Diaphragm diameter: 75mm. Suitable for many Renault (4CV, Dauphine, Floride, R4) + Peugeot (203,403,404). Citroën 11CV, HY, ID19.



Art.No.	Quality	needed qty
81361	4	1



Gasoline pump valve spring 9mm, for SEV gasoline pumps. Suitable for Citroën 11CV, 15CV. Citroën HY, ID19. Renault Dauphine, 4CV, R4. Peugeot 203 + 403



Art.No.	Quality	needed qty
60405	3	2



Gasoline pump valve chamber seal, for mechanical SEV gasoline pumps. Partly suitable for Citroën 11CV, 15CV. Citroën HY. Renault 4CV + Dauphine. Renault 203 + 403. Made in Germany.



Art.No.	Quality	needed qty
60403	3	1

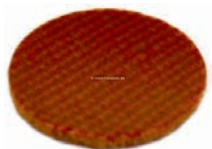

Gasoline pump valve flap (per piece), for SEV gasoline pumps. Dimension: 14 x 1mm. Suitable for Citroën 11CV, 15CV. Citroën HY, ID19. Renault Dauphine, 4CV, R4. Peugeot 203 + 403



Art.No.	Quality	needed qty
60406	3	2



Fuel pump seal for the connection at the engine block. Suitable for Citroën 2CV, Citroën DS after 1968, Renault, Peugeot. This seal replaces the paper gasket and is made of "KLINGERSIL". 0,5mm thick. Klingersil is an extremely resistant material, against oils, petrol, alcohol etc.



Art.No.	Quality	needed qty
10616	1	2



Gasoline pump seal (flange seal down). Suitable for Citroën 11CV, 15CV. Citroën HY + ID19. Or. No. 595022. Made in Germany.



Art.No.	Quality	needed qty
60408	3	2



Fuel hose fabric-encases. Inside diameter: 5,0mm. Outside diameter: 9,5mm. By meters. Customer cut, return not-possible!



Art.No.	Quality	needed qty
10526	1	1



Fuel hose fabric-encases. Inside diameter: 6,0mm. Outside diameter: 11,0mm. By meters. Customer cut, return not-possible!



Art.No.	Quality	needed qty
10527	1	1



Fuel hose fabric-encases. Inside diameter: 9,0mm. Outside diameter: 15,0mm. By meters. Customer cut, return not-possible!



Art.No.	Quality	needed qty
10528	1	1



Fuel hose metal-encases. (2CV6) Inside diameter: 5,5mm, outside diameter: 10,5mm. By meters. Customer cut, return not-possible!



Art.No.	Quality	needed qty
10522	1	1



Fuel hose metal-encases. Inside diameter: 3,5mm, outside diameter: 8,5mm. By meters. Customer cut, return not possible!



Art.No.	Quality	needed qty
10520	1	1



Fuel hose metal-encases. Inside diameter: 4,5mm, outside diameter: 9,5mm. By meters. Customer cut, return not-possible!



Art.No.	Quality	needed qty
10521	1	1

fuel system (pump, lines, transmitter, tank, tank cap) 0207



Fuel hose metal-encases. Inside diameter: 7,5mm, outside diameter: 12,5mm. By meters. Customer cut, return not-possible!



Art.No.	Quality	needed qty
10523	1	1



Fuel hose metal-encases. Inside diameter: 9,5mm, outside diameter: 15,0mm. By meters. Customer cut, return not-possible!



Art.No.	Quality	needed qty
10524	1	1



Fuel hose black fabric coated, for Citroën 2CV. (between gasoline pump + carburetors. By meters. Diameter: 5,5mm. Fasten please the hose with a hose clamp. Customer cut, return not possible!



Art.No.	Quality	needed qty
10124	3	1



Fuel hose connection (curved, 7 x 16mm), from the fuel sender to the gasoline line. Suitable for Citroën 11CV, 15CV + Citroën HY. Or. No. 595376



Art.No.	Quality	needed qty
60396	3	1



Fuel hose, only from rubber (not fabric encases). Inside diameter: 6,0mm. The hose is almost optical identical, to the early time used hoses. Customer cut, a return is not possible!



Art.No.	Quality	needed qty
10634	3	1



Fuel hose. Inside diameter: 3,2mm. Outside diameter: 8,5mm. By meters. Customer cut, return not-possible!



Art.No.	Quality	needed qty
10525	1	1

stabilisateur d'essence + octane booster
Fuel stabilizer - fuel additive - octane booster
Benzinestabilisator - Kraftstoffzusatz - Oktanzugabe



NEW!

Fuel stabiliser - fuel additive - octane booster from ELF/Total, for winter storage and storage of all 2 and 4-stroke engines. Ideal for our classic cars. Prevents corrosion in the tank and in the entire fuel system. Antioxidants prevent the fuel from ageing (the petrol remains ignitable). Binds and neutralises condensation in the tank. Eliminates starting difficulties when the vehicle has not been used for a long time. And as a special feature, the petrol additive has an octane booster. It therefore increases the ignitability of the petrol (knock resistance). Particularly interesting for regions in this beautiful world where there is no super petrol with at least 98 octane, or if you are involved in motor sports! Packaged in a high-quality aluminium can. Contents: 150ml. Application: 150ml is sufficient for 20 litres of petrol. Fill the tank completely. Fill in the fuel additive. Run the engine for 10 minutes. Done!



Art.No.	Quality	needed qty
21174	1	1



Gasoline stabilizer 250ml. Preserves and protects the fuel from ageing and oxidation. Prevents corrosion in the entire fuel system. Ensures problem-free immobilization of vintage cars, convertibles, motorcycles, scooters, quads, lawnmowers, chainsaws, and other petrol-driven 2-stroke and 4-stroke engines. Increases operational safety. With long-term effect. 25 ml from the dosing device preserve 5 l fuel. Before decommissioning, add the appropriate quantity to the tank and allow the engine to run for approx. 10 minutes.



Art.No.	Quality	needed qty
10617	2	1



Fuel tank 60 liters. Suitable for Citroën HY, all years of construction. Length: 640mm. Width: 250mm. Height: 470mm. Good reproduction. Or. No. H175-1C. The tank is made of zinc coated sheet metal.



Art.No.	Quality	needed qty
44840	3	1



Fuel pre-filter. For fuel pumps with round cover. Almost all available fuel pumps of our catalog are our own reproductions with removable cover. (round cover with 6 mm screw in the middle). Diameter about 41,4mm, bore 10,3mm.



Art.No.	Quality	needed qty
10615	2	1



Lead substitute (fuel additive) for older petrol engines, replaces the lubricating effect of the lead. 250ml bottle



Art.No.	Quality	needed qty
20087	1	1



Fuel pump cover gasket. For fuel pumps with round cover. Almost all available fuel pumps of our catalog are our own reproductions with removable cover. (round cover with 6 mm screw in the middle). Measurements about 44 x 36mm. 2mm heavily.



Art.No.	Quality	needed qty
10614	2	1



Diesel filter C112 (injection pump Bosch). Suitable for Peugeot 204, 304, 403, 404, 504. Citroën HY Diesel. CX Diesel, Visa Diesels. Height: 51mm. Outside diameter: 65mm. Inside diameter: 14mm. Or. No. 1906.02



Art.No.	Quality	needed qty
72071	3	1

0207 fuel system (pump, lines, transmitter, tank, tank cap)

1
2
3
4
5
6
7
8
9
10
11
12
13
14



Diesel filter (cartridge) C157A (injection pump Lucas/Roto Diesel). Suitable for Peugeot 404, 504, J7. Citroën HY Diesel. CX Diesel, Visa Diesel. Height: 73mm. Or. No. 1906.08



Art.No.	Quality	needed qty
72074	2	1



Diesel tank of 65 liters. Suitable for Citroën HY, all years of construction. Good reproduction. Or. No. HG175-12. The tank is made of zinc coated sheet metal.



Art.No.	Quality	needed qty
44907	3	1



Return stop (valve) for fuel or windscreen washer fluid. Connection: 6 mm. This valve is a real improvement for classic vehicles that use a hand pump without a ball valve to deliver water. This ensures that windscreen washer fluid is always available at the spray nozzles. Please note the direction of flow during installation! It also prevents petrol from flowing back in the fuel line (useful for longer periods of inactivity). Please install this valve close to the petrol pump (between the petrol pump and the tank).



Art.No.	Quality	needed qty
75315	3	1



Hose clamp gasoline line 8-12mm. Produced from high-grade steel!



Art.No.	Quality	needed qty
10608	1	4



T-connector fuel pipe, 3mm, also suitable for the screen wash.



Art.No.	Quality	needed qty
10449	3	1



T-connector fuel pipe, 4mm, also suitable for screen wash.



Art.No.	Quality	needed qty
10446	3	1



T-connector for fuel pipe, 5mm, also suitable for the screen wash.



Art.No.	Quality	needed qty
10447	3	1



Fuel filler cap lockable, color black. Suitable for Citroën 2CV, Dyane, DS, HY.



Art.No.	Quality	needed qty
16050	2	1



Fuel filler cap chromium-plates, lockable! Suitable for Citroën 2CV Dyane, DS, HY! For better rust protection please put regularly some oil on it.



Art.No.	Quality	needed qty
16145	4	1



Tank cap chrome-plated, lockable. Reproduction of the original. Suitable for 2CV/DS/11/HY/AK. Before you use the lock, please lubricate it! Note: Close and open the fuel filler cap only by a 1/4 turn! Otherwise the locking teeth can be damaged.



Art.No.	Quality	needed qty
16879	4	1

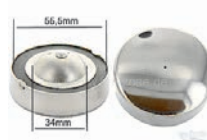

Chrome-plated fuel cap, non-lockable. (Metal). Suitable for 2CV, Dyane, AMI, HY, DS. The fuel caps are really well made. They also have a fuel vent, of course. Considering the price and quality, we highly recommend them.



Art.No.	Quality	needed qty
16846	3	1



Tank filler rubber seal, in the rear right fender. Colour grey. Fits Citroën 2CV from 1967 to 1990, Citroën DS up to 1974, HY from 09/1968, 11CV from 7/1952.



Art.No.	Quality	needed qty
16143	3	1



Tank filler rubber seal, in the rear right fender. Colour black. Fits Citroën 2CV from 1967 to 1990, Citroën DS up to 1974, HY from 09/1968, 11CV from 7/1952.



Art.No.	Quality	needed qty
16087	3	1



Rubber seal for the tank neck. Old version. Color: beige. Citroën 2CV to about year of construction 1967. Citroën AZU. Citroën HY, to year of construction 09/1968.



Art.No.	Quality	needed qty
16493	3	1



Rubber seal for the tank neck. Old version. Color: grey. Citroën 2CV to about year of construction 1967. Citroën AZU. Citroën HY, to year of construction 09/1968.



Art.No.	Quality	needed qty
16407	3	1



Rubber seal for the tank neck. Old version. Color: black. Citroën 2CV to about year of construction 1967. Citroën AZU. Citroën HY, to year of construction 09/1968.



Art.No.	Quality	needed qty
16406	3	1

fuel system (pump, lines, transmitter, tank, tank cap) 0207

Filtre de la sonde du réservoir
Fuel sensor filter
Benzindrifter Tankgeber



Fuel tank sensor Fuel filter. This filter (universal fitting) is mounted at the bottom of the fuel intake pipe of the fuel tank sensor. Universal fitting. Length: approx. 40mm. Inner diameter: 6mm.



Art.No.	Quality	needed qty
14134	3	1

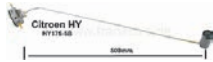

Fuel sender, suitable for Citroën HY. Or. No. HY175-5B. !! Attention: The fuel sender has 2x connections for the fuel gauge. But only one connection is used. Depending on whether the fuel gauge has an integrated series resistor or not (was just available in the factory). Please try out which connection fits your gauge. The earth (groend) is still connected via the housing!



Art.No.	Quality	needed qty
44868	3	1

Citroën 2CV, DS
Dynam, AK, Mehari, AZU...
Renault 4L4, Capoline, etc...
Peugeot 205, 306, 406...



Fuel sender - float, reproduction, for Citroën 2CV. Dimensions: 27 x 66mm. The groove for the hook have a diameter of 21mm.



Art.No.	Quality	needed qty
14211	3	1



Fuel sender seal from rubber. Suitable for Citroën 2CV + Citroën DS, Renault. Per piece.



Art.No.	Quality	needed qty
14135	2	1



Fuel sender seal, old version, for metal tank. Suitable for Citroën 2CV, DS, HY. You can use the seal also with a tank from plastic (Citroën 2CV). Made in Germany.



Art.No.	Quality	needed qty
14186	4	1



FRENCH AUTOMOBILE CULTURE



www.cipere.fr

www.franzose.de

www.franzose.com

0208 ignition

1
2
3
4
5
6
7
8
9
10
11
12
13
14



Citroën HY Diesel, Peugeot Diesel.....
Chrome-plated cover for the preheating indicator (also known as the 'salt shaker'). Original for Bosch preheating system. These are original covers, not replicas! Suitable for Citroën HY with Indenor diesel, for example. Many classic Peugeot models with Indenor diesel engines. Original number Citroën: HG721-73. Thread: M26x1



Art.No.	Quality	needed qty
44932	1	1



Sealing rubber (rubber ring) under the valve cap. Seal for the plug body. Suitable for Citroën DS, Citroën HY, Citroën CX.



Art.No.	Quality	needed qty
30021	3	4



Bosch, ignition contact system Bosch. The contact is struck clockwise. Suitable for Citroën DS21 IE, up to year of construction 12/1971. Peugeot 304 + Peugeot 104. Depending on availability, the ignition contact is supplied from another brand manufacturer. Made in France.



Art.No.	Quality	needed qty
32286	2	1



Ducellier, condenser (12 Volt). Suitable for Citroën ID + DS, starting from year of construction 1972. Citroën HY, CX Athena. Renault R4 GTL (R1123, 1126, 2106, 2109, 2391, 2392). Peugeot 304, 403, 404, 504. This condenser can be used also for SEV!



Art.No.	Quality	needed qty
34026	2	1



Ducellier, ignition contact (D304). Suitable for nearly all French car's with Ducellier distributor. E.G. Citroën DS, Citroën 11CV, HY. Peugeot 204, 304, 203, 403, 404, 504, J7. Renault R4, R5, R6, R8, R10, R12, R16, R17. Length of the contact: about 37mm. The cable is firmly mounted at the contact.



Art.No.	Quality	needed qty
34028	2	1



Ducellier, ignition contact + condenser (D304). Suitable for Citroën DS (engine DY3). Citroën HY. Peugeot 304, 404, 504, J7. Renault R4, R5, R6, R8, R10, R12, R16, R17. Contact length: 37mm. The connection cable is firmly mounted on the contact.



Art.No.	Quality	needed qty
48157	3	1



Ducellier, ignition contact. Suitable for Citroën DS, to year of construction 1962. Citroën HY + Citroën 11CV. Also Installed in various Renault (Estafette), Peugeot. Made in France.



Art.No.	Quality	needed qty
32275	2	1



Ducellier, ignition contact. Suitable for Peugeot 204 + Citroën HY. System Ducellier D327. Cable length: about 40cm. Original, no reproduction (NOS). Or. No. 5945.12



Art.No.	Quality	needed qty
72095	2	1



Ducellier, distributor arm, original manufacturer. Suitable for Citroën DS starting from year of construction 9/1972, CX up to 1980, HY. Renault R4GTL, R5, R16. Peugeot 204, 304S, 404, 504. Version D216. Length over everything: 46mm. Height over everything: 36mm. Inside diameter: 15mm. Or. No. Citroën: 5452421. Peugeot: 5937.05. Renault: 0854120600



Art.No.	Quality	needed qty
34031	2	1



Ducellier, distributor arm. Suitable for Citroën DS (from year of construction 04/1966 to 10/1972), HY, BX, C15, CX, Visa, XM, GS. Peugeot 504, 205, 505, 104. Renault R11, R18, R19, R21, R12. Mounting: 10mm inside diameter. Rotor length over everything = 48 mm. Rotor level over everything = 31 mm. Setting up depth = 13 mm. Or. No. Peugeot: 5937.28. Renault: 7701026824. Citroën 95559241 + 95611732



Art.No.	Quality	needed qty
72010	2	1



Ducellier, distributor arm. Suitable for Citroën DS (from year of construction 04/1966 to 10/1972), HY, BX, C15, CX, Visa, XM, GS. Peugeot 504, 205, 505, 104. Renault R11, R18, R19, R21, R12. Mounting: 8mm inside diameter. Rotor length over everything = 48 mm. Rotor level over everything = 31 mm. Setting up depth = 13 mm. Or. No. Peugeot: 5937.22. Renault: 7701020357



Art.No.	Quality	needed qty
82354	2	1



Ducellier, distributor cap (D801), lateral ignition cable outlet. Suitable for Citroën DS, CX, GS, HY, Visa, LNA. Renault R5. Made in France.



Art.No.	Quality	needed qty
34033	3	1

Ducellier



Ducellier, distributor cap + distributor arm (lateral ignition cable inlet). Suitable for Citroën DS, CX, GS, Visa, HY. Peugeot 504, 505. Renault R5, R6. Simca Talbot 1100, Matra, Bagherra, S-Rancho. Original manufacturer.



Art.No.	Quality	needed qty
34102	2	1

Ducellier



Ducellier, distributor cap + distributor arm. Suitable for Citroën DS, from of year of construction 10/1959 to 04/1966. Citroën HY. Renault Alpine 1300, from of year of construction 01/74 to 12/75. Peugeot 204 + 304, 404, 504. Renault R4, R5, R6, R10, R12, R15, R16, R17, R20. Height over everything: 65mm. Inside diameter: 65mm.



Art.No.	Quality	needed qty
82633	3	1

Ducellier



Ducellier, distributor cap, ignition cable outlet above (D216). Suitable for Citroën DS (up to year of construction 1972). Citroën HY + 11CV. Peugeot 204, 304, 403, 404, 504. Renault R4, R16. Diameter on distributors: 64mm. Height over everything: 65mm. Inside diameter: 65mm. Made in France.



Art.No.	Quality	needed qty
34034	2	1

Citroen DS



Electronic ignition, 6 + 12 V. Suitable for all Citroën DS, 11CV, HY, with vacuum connection at the distributor. Angled distributor cap, ignition cable connection laterally. This electronic ignition is very simple to install and has no mechanical components, which can wear. You will be enthusiastic! We sold already more than 5000 ignitions.



Art.No.	Quality	needed qty
34303	1	1

Citroen DS



Electronic ignition, 6 + 12 V. Suitable for all Citroën DS, 11CV, HY, with vacuum connection at the distributor. Straight distributor cap, ignition cable connection from above. This electronic ignition is very simple to install and has no mechanical components, which can wear. You will be enthusiastic! We sold already more than 5000 ignitions.



Art.No.	Quality	needed qty
34304	1	1

Citroen DS



Electronic ignition, 6 + 12 V. Suitable for all Citroën DS, 11CV, HY, without vacuum connection at the distributor. Angled distributor cap, ignition cable connection laterally. This electronic ignition is very simple to install and has no mechanical components, which can wear. You will be enthusiastic! We sold already more than 5000 ignitions.



Art.No.	Quality	needed qty
34300	1	1

Citroen DS



Electronic ignition, 6 + 12 V. Suitable for all Citroën DS, 11CV, HY, without vacuum connection at the distributor. Straight distributor cap, ignition cable connection from above. This electronic ignition is very simple to install and has no mechanical components, which can wear. You will be enthusiastic! We sold already more than 5000 ignitions.



Art.No.	Quality	needed qty
34301	1	1

Citroen DS



Electronic ignition, 6 + 12 V. Suitable for all Citroën DS, with "DV" engines. Installed from year of construction 1966 to 1967. Without vacuum connection at the distributor. Straight distributor cap, ignition cable connection from above. The distributor is at the front side from the engine Installed. This ignition fits for Ducellier and SEV Marchal distributor.



Art.No.	Quality	needed qty
34311	1	1

Peugeot 404 D, 504 D



Glow plug. Thread: 10,5V, M18x1,5. Wrench: 21mm. Suitable for engine: XD4.88. The engine built into: Peugeot 404 D. Peugeot 504 D (early years of construction). Citroën HY Diesel.



Art.No.	Quality	needed qty
72143	2	4

Ducellier



Condenser Ducellier. Connection: Round plug. Suitable for Citroën HY, GSA, CX, Visa, Peugeot 204, 104. Made in France.



Art.No.	Quality	needed qty
42080	2	1

Paris Rhone



Paris Rhone, distributor cap Paris Rhone, suitable for Citroën ID19 + Citroën HY. Inside diameter: 65mm. Overall height totally: 65mm.



Art.No.	Quality	needed qty
32360	3	1

SEV



SEV, condenser. Suitable for Citroën DS (with SEV contact cartridge, starting from year of construction 01/1969), GSA, HY. Peugeot 404, 504 etc.. Renault R4, R5, Fuego etc.. Length: 35,5mm. Diameter: 17,0mm. Brand manufacturer! Made in France.



Art.No.	Quality	needed qty
34024	2	1

0208 ignition

1
2
3
4
5
6
7
8
9
10
11
12
13
14



SEV S403
SEV, ignition contact (large sickle type). Version SEV S403. This contact fits nearly for all French cars, from the fifties + sixties, which have a SEV distributor. E.G. for Citroën ID-DS (year of construction 7/1954 to 8/1967). Citroën 11CV + HY. Peugeot 403 + 404 (of year of construction 1960 to 1975). Renault Dauphine, Floride, Caravelle, R6, Estafette. Talbot all models, with SEV distributor. Made in France.



Art.No.	Quality	needed qty
34027	2	1



SEV, ignition contact SEV, short version. Suitable for Citroën DS, to year of construction 03/1972. Citroën 11CV + HY. Peugeot 404, starting from year of construction 1968. Renault R4, early years of construction. Renault Floride, Dauphine etc. Simca + Talbot, different models. Or. No. DS: DY211217A. Or. No. Peugeot: 592724 + 592726.



Art.No.	Quality	needed qty
34084	3	1



SEV, distribution arm for distributor cap 48134. Suitable for Citroën 11CV, HY, DS, Peugeot, Citroën. Inside diameter 14mm. (Mounting at the distributor). Depth of the mounting 8,5mm. Distributor arm length over everything = 50mm.



Art.No.	Quality	needed qty
48247	3	1



SEV, distributor arm SEV 466. Suitable for Citroën 11CV, starting from year of construction 1942. Citroën HY. Peugeot 202, Peugeot 203 starting from year of construction 1949. Peugeot 403, starting from year of construction 1955. Peugeot 404, starting from year of construction 1960. Renault R4, Fregate, Juva, Dauphine, Floride. Simca 8, Aronde, Ariane. Suitable distributor cap: 72182



Art.No.	Quality	needed qty
72183	3	1



SEV, distributor rotor SEV. Type S4510. For distributors with contact cassette. Suitable for Citroën DS + HY. Peugeot 504 GR, SR (from year of construction 1979). Renault R4 GTL (R1128, 2370 2430), R8, R10, R12, Renault R16, R18, Fuego. Matra Bagheera. Or. No. Peugeot: 5937.27 + 5937.07. Renault: 7701020056



Art.No.	Quality	needed qty
34032	2	1



SEV, distributor arm. Suitable for Renault R4, Renault rear engine. Peugeot 203, 403, 404. Citroën DS, Citroën HY. Or.Nr.8556679. Length over everything: 50mm. Height over everything: 25mm. Inside diameter 14mm.



Art.No.	Quality	needed qty
82618	2	1



SEV, distributor cap SEV 453. Outside diameter: 58,7mm. Suitable for Citroën 11CV, starting from year of construction 1942. Citroën HY. Peugeot 202, Peugeot 203 starting from year of construction 1949. Peugeot 403, starting from year of construction 1955. Peugeot 404, starting from year of construction 1960. Renault R4, Fregate, Juva, Dauphine, Floride. Simca 8, Aronde, Ariane. Suitable distribution arm: 72183



Art.No.	Quality	needed qty
72182	3	1



SEV, distributor cap, firm carbon pins. Distributor diameter: 63,0mm. Suitable for Citroën 11CV, HY, DS, Peugeot, Citroën. The suitable distribution arm has our number 48247. Or. No. DM211-15A + DM211-15B



Art.No.	Quality	needed qty
48134	3	1



SEV, distributor cap. Suitable for Citroën HY. Renault Renault Fuego (136) 1,6TS/GTX + 2,0TX/GTX (1362-63). R18 (134) 1,6Turbo + R18 1.4, to year of construction 08/1982. R8, R10, R12, R16. Peugeot various (505). Peugeot Or. No. 5941.11. Made in France.



Art.No.	Quality	needed qty
82218	3	1



Shaft seal, for the distributor. Suitable for Citroën DS + Citroën HY. Dimension: 9 x 16 x 5mm. Or. No. 26126389P. Made in Germany.



Art.No.	Quality	needed qty
32218	3	1



Vacuum can Ducellier. Suitable for Ducellier distributor, last version for Citroën 11CV, HY. Peugeot 404 + 504. Original from Ducellier, no reproduction (NOS). Ducellier No. 660333



Art.No.	Quality	needed qty
71343	1	1



Ignition cable fixture (only plastic). Suitable for Citroën DS + Citroën HY. Or. No. DX212-248A + 1D 5451455W



Art.No.	Quality	needed qty
32391	3	1



Ignition cable fixture set. Consisting of the fixture (for 4 cables) above the ignition coil + fixture (2 cables) suitable for cylinder No. 3 + 4, for Citroën DS, Citroën HY, Citroën GS. Or. No. GX0610801A + DX212-286A



Art.No.	Quality	needed qty
32392	3	1



Citroën DS + HY
Ignition cable holder. Suitable for Citroën DS + Citroën HY. This holder is screwed on the valve cover. (at the fixing screws of the valve cover)



Art.No.	Quality	needed qty
32216	3	1



Citroën HY - 1974
Orange 11CV
Ignition cable set, suitable for Citroën 11CV. Citroën HY, up to model year 1963. Or. No. 715024. Caution: These ignition cables are high-resistance and can only be used with low-resistance spark plugs (so no spark plugs with an R in the designation. R = radio-control = high resistance).



Art.No.	Quality	needed qty
60147	3	1



Citroën DS 1965+ Citroën HY
Ignition cable set, suitable for Citroën DS (carburetor engine, starting from year of construction 1965) + Citroën HY, with in front mounted distributor. The ignition cable set is delivered with suitable spark plug sockets. Made in EU.



Art.No.	Quality	needed qty
34037	2	1



Citroën DS + HY
Spark plug electrode extension. Suitable for Citroën DS + Citroën HY. Or. No. 2D5416220G, DX21272B



Art.No.	Quality	needed qty
34106	3	4



Peugeot 403, 404, 504 Renault R16, Citroën DS
Spark plug electrodes extension. Suitable for Peugeot 403, 404, 504, J7. Renault R16. The extension fits also on Citroën DS + HY. With Citroën DS can be, that the rubber protection from the ignition cable, must cut off a little bit. It can be, that you must change the hole from the spark plug locking cap to 10mm. Normally no changes are necessary. Just opposite DS, the extensions from the Peugeot method is an significant improvement, because the electrode is fully insulating!



Art.No.	Quality	needed qty
72003	1	4



Citroën DS, HY, CX
Spark plug isolation pipe. Material such as original (PF CP 21). Suitable for Citroën DS, HY, CX. Dimension: 13 x 15 x 105mm. Or. No. DX212-77. Made in Germany



Art.No.	Quality	needed qty
34078	3	4



Citroën DS, HY, 11CV, 15CV
Spark plug NGK BP6 HS. Suitable for all Citroën DS models, Citroën HY, Citroën Traction 11cv and 15six. Short thread. Thread: M14 x 1.25 x 10mm. Wrench 21mm.



Art.No.	Quality	needed qty
34039	2	4



Spark gap measurement (testing) tool. With the help of this small, inexpensive tool, the spark gap of the spark plug can be checked very easily and safely. So, if the engine does not start: Is the spark plug sparking at all! And if so, how strong! Then exclusion procedure: Ignition OK? It is not getting any petrol!



Art.No.	Quality	needed qty
20559	3	1



Flexible Spark Plug Remover/Installer. This specially designed tool allows access to spark plugs where they are deep seated or require off-line access. The tool is also designed to grip the spark plug securely allowing the removal with ease.



Art.No.	Quality	needed qty
21046	1	1



Tap drill M14x1,25. (Spark plug threads).



Art.No.	Quality	needed qty
20946	3	1



Heli coil spark plug thread repair set. For all M14 spark plugs. Contents: 1 bore + cutting tool, installation spindle. 10x heli coil insert M14x1,25x17,5. (Spark plugs with long threads). 10x heli coil insert M14x1,25x12,7. (Spark plugs with short threads, 2CV, R4).



Art.No.	Quality	needed qty
20947	2	1



Spark plug thread Helicoil insert. M14x1,25x12,7 (spark plugs with short thread 2CV, R4). Refill package (10 pieces)!



Art.No.	Quality	needed qty
20948	2	1



Spark plug wrench (adjustable in length), for 20,8mm spark plugs. This key is perfect for the Citroën DS. It can be used with the normal electrode extension. Fitting for 3/8 inch ratchet (medium size). Fits of course also on all other spark plugs, for 21mm tools. Manufacturer: HAZET. Adjustable length from: 137,5mm to 157,5mm and 195,5mm. With spark plug holding rubber.



Art.No.	Quality	needed qty
21076	1	1



Citroën DS Peugeot 203, 403, 404, 504
Spark plug wrench (tube wrench), for 20,8 mm spark plugs. 300mm long! Particularly for Citroën DS, Peugeot 203, 403, 404, 504. Workshop quality!



Art.No.	Quality	needed qty
20094	2	1

0208 ignition

1
2
3
4
5
6
7
8
9
10
11
12
13
14



Citroën DS + HY

Spark plug socket (only the plastic part, which is pressed on the valve cap). Suitable for Citroën DS + Citroën HY.



Art.No.	Quality	needed qty
32383	3	4



Spark plugs plug 90° bent.



Art.No.	Quality	needed qty
72900	3	4



12 Volt

Ignition coil 12 volt (Bosch), without pre-resistor. Suitable for Citroën DS, GS, HY. Peugeot 203, 204, 304, 403, 404, 504, J7. Renault R4, R5, R16 etc.. We have it again, the original Bosch Asphalt ignition coil! The ignition coil owes its name to the fact that asphalt is used for the insulation inside the coil (just like before!)



Art.No.	Quality	needed qty
34659	2	1

NEW!



12 Volt

Ignition coil with pre-resistor. 12 V. Brand manufacturer! Suitable for Citroën DS, CX, GS, AMI8 Super. Peugeot 403, 404, 504, 505. Renault R4, R5, R12, R16 etc.



Art.No.	Quality	needed qty
34042	2	1



12 Volt

Ignition coil 12 V, without pre-resistor. Suitable for Citroën DS, GS, HY. Peugeot 203, 204, 304, 403, 404, 504, J7. Renault R4, R5, R16 etc.. Original VALEO



Art.No.	Quality	needed qty
34067	2	1



6 Volt

Ignition coil 6 V. Manufacturer: Bosch! Suitable for Renault (4CV, Floride, Dauphine, Estafette, R4). Citroën 11CV, HY.



Art.No.	Quality	needed qty
82303	2	1

6 Volt



Ignition coil 6 V. Suitable for Renault, Citroën 11CV, HY. Reproduction



Art.No.	Quality	needed qty
82300	4	1

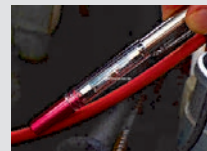

Spark Indicator. This non-contact spark tester will test for the presence of power in spark plugs, coils and distributors. Simply place the grooved end over the spark plug wire with the engine running and the high intensity bulb will flash indicating spark. Note: Depending upon screen of the ignition cables, it can be possible, that you see the flashing by daylight, very bad!



Art.No.	Quality	needed qty
20506	1	1



Citroen HY



Clutch release sleeve, like original! Suitable for Citroën HY. Premium reproduction. With graphitic ring! Or. No. HY314-07



Art.No.	Quality	needed qty
48246	3	1

Made in Germany



Spring for brake pedal + clutch pedal. Suitable for Citroën HY, Installed starting from year of construction 12/1969. Diameter: about 20mm. Length: about 155mm. 41 turns. Or. No. HY435-25. Note: With Citroën HY, from year of construction 12/1967 to 12/1969, is installed 1x spring article no. 48240 (ZC9089071u clutch) + 1x article no. 48292 (HY435-25 brake).



Art.No.	Quality	needed qty
48292	3	2



Spring for brake pedal + clutch pedal. Suitable for Citroën HY, Installed up to year of construction 12/1967. Diameter: about 12mm. Length: about 220mm. 31 turns. Or.Nr. ZC9089071U. Note: With Citroën HY, from year of construction 12/1967 to 12/1969 is 1x the spring article no. 48293 (ZC9089071u clutch) + 1x article no. 48292 (HY435-25 brake) Installed.



Art.No.	Quality	needed qty
48293	3	2



Spring for the clutch cable at the bottom. Suitable for Citroën HY. Or. No. H142-5.



Art.No.	Quality	needed qty
48240	3	1

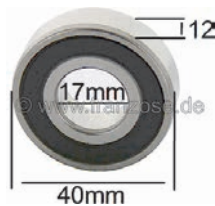

Ball bearing for the fly wheel. Suitable for Citroën HY. Inside diameter: 17,0mm. Outside diameter: 40,0mm. Overall height: 12,0mm.



Art.No.	Quality	needed qty
42095	4	1



Clutch pressure plate (new part). Suitable for Citroën HY, from year of construction 10/1968. Or. No. HY8312-000B. The pressure plate are adjusted after Citroën work instruction H312/3 to a clutch disk with 9,3mm thickness. If your clutch disk should have another thickness, the pressure plate must be readjusted after Citroën instruction H312/3! Made by Franzose.



Art.No.	Quality	needed qty
48030	3	1



Clutch pressure plate adjustment tool MR-3457-30. Suitable for Citroën HY, from year of construction 10/1968. This tool is for the height adjustment of the pressure plate. The pressure plate must be adjusted very accurately with each clutch assembly. Very important! See Citroën working instruction H312-3!



Art.No.	Quality	needed qty
48375	3	1



Clutch pressure plate spring set (repair set) + thrust ring pressure plate. Suitable for Citroën HY, of year of construction 10/1968 to 1981.



Art.No.	Quality	needed qty
48377	3	1

Citroen ID, DS + HY



Clutch pressure plate with 3 fingers: Nut for adjustment of the levers (fingers). Thread: M8. Lead of thread: 0,75. Wrench: 14mm. Or. No. ZC9491056U



Art.No.	Quality	needed qty
30386	3	3

Citroën HY



Clutch adjustment tool, for checking and adjusting the clutch release sleeve. Citroën No. MR-3657, suitable for Citroën HY. Attention: The adjustment of the clutch release sleeve is very important for the Citroën HY!



Art.No.	Quality	needed qty
48404	3	1



Complete clutch, new parts only. Suitable for Citroën HY, starts from 10/1968 to 1981. Consisting of: Pressure plate, pressure plate adjustment tool, clutch disk, release bearing. Attention: Please do follow the original Citroën working instructions H312-3, for the adjustment of the pressure plate, position of the release bearing, adjustment of the pedal travel! It is absolutely necessary to work according to the instructions for the Citroën HY. Please read first, then start working! Many things are adjusted differently than known from modern cars! A correct function is not given, if you do not work according to the original workshop manual!



Art.No.	Quality	needed qty
48376	3	1



Clutch Alignment Tool, Universal. For single plate clutches. Suitable for flywheels with or without pilot bearing. Fast to fit and remove. Universal applications. Size of collets: 14mm to 28mm across 3 adaptors. Cone size range from 35mm < 67mm (for almost all classical french cars)



Art.No.	Quality	needed qty
20555	1	1

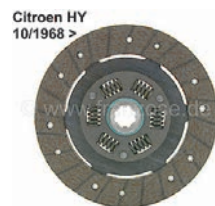

Clutch disk, new part. Suitable for Citroën HY, starting from year of construction 10/1968. 8 teeth. Diameter: 215mm. Thickness under load: 9,3mm. Or. No. H313-01B. Made in Europe



Art.No.	Quality	needed qty
48032	3	1

0209 clutch

0210 clutch cables

Citroën HY



Clutch disk, new part. Suitable for Citroën HY, to year of construction 10/1968. Diameter: 215mm. Or. No. H31301A



Art.No.	Quality	needed qty
48031	3	1

Citroën HY/1968 > 1981
Peugeot 404



P 404/HY, thrust ring for the clutch pressure plate. Suitable for Peugeot 404. Citroën HY, of year of construction 10/1968 to 1981.



Art.No.	Quality	needed qty
71218	4	1

Citroën 11CV (Perfo)
Citroën HY > 05/1957



Fly wheel screw. M8 x 24 (1 side flat bolt head). Suitable for Citroën 11CV with perfo engine (to year of construction 1955). Citroën HY until May 1957. Or. No. 453038



Art.No.	Quality	needed qty
42096	3	6



Clutch cable, suitable for Citroën HY, starting from year of construction 1969. Overall length: 400mm. Or. No. HY3142B



Art.No.	Quality	needed qty
48058	3	1



Clutch cable, suitable for Citroën HY, to year of construction 1969. Or. No. H3142A



Art.No.	Quality	needed qty
48057	3	1

DerFranzose
Citroën Peugeot Renault
www.franzose.com



1
2
3
4
5
6
7
8
9
10
11
12
13
14

generator + spare parts 0211
V-belt 0212



cap connection generator
Gelenkhaube Antriebs Lichtmaschine

Rubber cap for the connection at the generator. (Protecting cap). This cap should never be missing. Universal fitting! For max. cable diameters: 7,62mm. Inside diameter 12,7mm.



Art.No.	Quality	needed qty
14262	3	1



bearing for alternator DS >3/71 Lima Paris Rhone (A13R52)



Art.No.	Quality	needed qty
34087	2	1



Bearing rear, for the generator Paris Rhone, 12Volt. Suitable for Citroën HY. Dimension: 12.0 x 32.0 x 10,0mm. Or. No. ZC9620316U



Art.No.	Quality	needed qty
48069	3	1



Citroën HY >1963

Generator with integrated battery charging regulator, new part. Suitable for Citroën HY, to year of construction 1963. 12 V, 55 ampere, alternating current.



Art.No.	Quality	needed qty
48330	1	1



Citroën HY

Generator with integrated battery charging regulator. Suitable for Citroën HY, starting from year of construction 1964. 12 V, 55 ampere, alternating current.



Art.No.	Quality	needed qty
48068	3	1



Citroën HY 1968 - 1981

Alternator with integrated alternator regulator. Suitable for Citroën HY (petrol engine), from the year of construction 1968 to 1981. This 12 Volt high-performance alternator delivers 70A. Ideal for those who require a high charging capacity (campervan, food truck etc.).



Art.No.	Quality	needed qty
48403	1	1



12 Volt

Generators battery charging regulator three-phase current 12V, universal. Connections: IGN= clamp 15. FLD= DF at generator (connection at the brush). Ground on case! Optically very nice. Dimension case: 64mm x 40mm. Overall height: 56mm. Dimension screwed joint sub-base: 83mm x 83mm. Screwed joint distance (slotted holes) from 60 to 70mm.



Art.No.	Quality	needed qty
72536	3	1



Citroën 2CV + HY

6 Volt A533-17B

Generator Brush locking spring for 2CV with 6 V, Citroën HY with 6 V. For generator Paris Rhone. Or.Nr.A533-17B



Art.No.	Quality	needed qty
14263	1	2



Paris Rhone A13M12

Generator Brush Set, for Paris Rhone A13M12. Suitable for Peugeot, Renault, Citroën (2CV, DS). Length: 19mm. Thickness: 5mm. Height: 7mm.



Art.No.	Quality	needed qty
72103	2	1



10 x 1100

V-belt 10x1100mm. Suitable for Peugeot 204, 304. Citroën HY Diesel



Art.No.	Quality	needed qty
72124	3	1



V-belt for the generator. Dimension: 10 x 1250. Suitable for Citroën HY, starting from year of construction 12/1968.



Art.No.	Quality	needed qty
48074	3	1



V-belt for the generator. Dimension: 10 x 1300. Suitable for Citroën HY, of year of construction 1963 to 1968. Peugeot J9 Diesel. Or. No. HY231-6



Art.No.	Quality	needed qty
48075	3	1



V-belt for the generator. Dimension: 17 x 1150. Suitable for Citroën HY, to year of construction 9/1963.



Art.No.	Quality	needed qty
48076	3	1



0213 starter

1
2
3
4
5
6
7
8
9
10
11
12
13
14



Citroën HY
Starter motor, new part. 12 V. Suitable for Citroën HY. Specially made! An old part return is not necessary! For mounting: Mount the small cable bridge (between the screw connection 8mm and the tongue connection above). This cable bridge is included with the starter. Function with the HY: The starter relay at the positive pole cable at the battery switches directly the terminal 30 (plus) at the starter. Now the current flows via the cable bridge to terminal 50 (tongue connection, control connection). This causes the solenoid switch to pull in and push the pinion forward. This closes the contact on the starter itself.



Art.No.	Quality	needed qty
48331	1	1



Starter motor, suitable for Peugeot 404 D. Peugeot 504 1,9D. Citroën HY Diesel. 12V. Power: 1,95KW. Teeth: 9 teeth. 3 mounting holes. Mounting position: On the left of 48°. Direction of rotation in in the clockwise direction. The starter motor is a new part. An old part return is not necessary!



Art.No.	Quality	needed qty
72107	3	1



Starter brushes Paris Rhone. Suitable for Citroën DS. up to year of construction 1971. These starter brushes are mounted also in many other French vehicles. For starter motor Paris Rhone, series D10. Width: 18,0mm. Height: 14,0mm. Depth: 7mm. Or. No. Citroën: DX533111A + Peugeot: 182064



Art.No.	Quality	needed qty
34090	2	2



Starter brushes Paris Rhone. Suitable for Citroën ID19. Citroën HY. Citroën 11CV + 15CV. Dimension: 18 x 7mm. Or. No. 701863



Art.No.	Quality	needed qty
60528	3	1

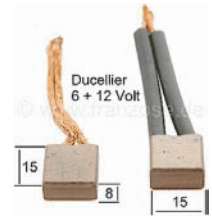

Starter brushes, for Ducellier 6 V + 12 V. Suitable for Citroën AMI6 + AK to year of construction 1966 (6 V, A533-15). Citroën HY, 12 V (Or. No. 2D5423368C). Peugeot 203, 403, 404, 204. Panhard. Renault Dauphine, R8, Floride, Caravelle, R4, Estafette. Simca. Dimension: 15,0 x 8,0 x 15,0mm.



Art.No.	Quality	needed qty
48073	3	1



Starter relay 6 V, 200 ampere. Suitable for vehicles with 6 V technology. (Citroën 11CV, Dauphine.)



Art.No.	Quality	needed qty
60111	3	1



Starter relay, mounted at the positive terminal of the battery. With 90cm cable. Suitable for Citroën DS (with left mounted battery) + Citroën HY. Or. No. 2D5401570T



Art.No.	Quality	needed qty
34071	3	1



Exhaust manifold heat shield spacer. This spacer is mounted between the starter motor and the heat shield (for small diameter starter motors only). Thread: M8. Suitable for Citroën DS, HY. Or. No. DX533262A



Art.No.	Quality	needed qty
31016	3	1



Rubber cap for the connection to the starter motor. (Protecting cap). This cap should never be missing. Universal fitting! For max. cable diameters: 17,8mm. Inside diameter 22mm.



Art.No.	Quality	needed qty
14657	3	1



Bearing bush, for starter motor Paris Rhone. Suitable for Citroën DS + HY. Dimension: 16 x 20 x 16mm. Or. No. DF53340



Art.No.	Quality	needed qty
34075	2	1



Knob "D" for starter motor Bowden cable. Suitable for Citroën 11CV, 15CV, 2CV old, HY. The handle is oval and from aluminum.



Art.No.	Quality	needed qty
60807	3	1



Citroën 2CV + HY

Label for the heater adjustment (red + blue spot). Suitable for Citroën 2CV + HY.

Art.No.	Quality	needed qty
17502	3	1

Citroën HY

Threaded knob for the ventilation flap. Suitable for Citroën HY. High-quality reproduction.

Art.No.	Quality	needed qty
44933	3	2

Citroën DS + HY

Fan engine for the heating. New part. Suitable for Citroën DS + Citroën HY. Or. No. DX642-228A

Art.No.	Quality	needed qty
32295	4	1

Citroën HY

Rubber bush, for the screwed joint from the heater casing. Suitable for Citroën HY. Or. No. D565-104

Art.No.	Quality	needed qty
48344	3	6

12 x 20 x 17mm

**Citroën DS > 1968
Citroën HY**

Rubber knob for the heater flow control valve, in the interior (engine tunnel). Suitable for Citroën DS Non Pallas, up to year of construction 1968. Citroën HY for the heating. Or. No. ZC9804104U

Art.No.	Quality	needed qty
32262	3	1

chauffage heating Heizung

Citroën HY

Heating hose (fresh air hose) above. Suitable for Citroën HY. Inside diameter: 70mm. Length: 660mm.

Art.No.	Quality	needed qty
48244	3	1

Citroën HY

Heating hose. Suitable for Citroën HY. Inside diameter: 50,0mm. Length: 1050,0mm. In the Citroën HY, until year of construction 06/1966, the hose was 880mm long. From the year of construction 7/1966, the hose has been 1020mm long. Please cut to length!

Art.No.	Quality	needed qty
48243	3	1

Citroën DS + HY

Heater radiator retaining clip (locking spring). Suitable for Citroën DS + HY. Or. No. DX642-269A

Art.No.	Quality	needed qty
32490	3	1

Citroën DS + HY

Heater radiator hose 90°. Suitable for Citroën DS + HY (e.g. old version heater radiator). Leg length about 25mm both sides. Inside diameter about 12-15mm. Or. No. DF642-79

Art.No.	Quality	needed qty
32443	3	1

Citroën 2CV, HY, Mehari

Heater adjustment lever with fixture. Suitable for Citroën 2CV, HY, Mehari. Reproduction out of painted sheet metal. Or. No. 5403748

Art.No.	Quality	needed qty
14529	3	1

Citroën 2CV

Heater adjustment lever with fixture. Suitable for Citroën 2CV, HY, Mehari. Chrome-plated. Or. No. 5403748

Art.No.	Quality	needed qty
14515	3	1

Citroën DS

Heater valve (spiral) retaining clip. Suitable for Citroën DS. Or. No. DX642-110

Art.No.	Quality	needed qty
32491	3	1

Citroën 2CV/DS

Cable tie made of rubber, for 2CV/DS, like the original. Length: 270mm, breadth:12mm. Made in Germany. Now manufactured from improved material (NBR/SBR fabric rubber)

Art.No.	Quality	needed qty
16156	3	2

Citroën 2CV/DS

Cable tie made of rubber, for 2CV/DS, like the original. Length: 320mm, breadth: 12mm. Made in Germany. Now manufactured from improved material (NBR/SBR fabric rubber)

Art.No.	Quality	needed qty
16583	3	2

**Citroën 2CV
Citroën HY + 11CV**

Knob for opening mechanism of the Ventilation shutter. Color blue, production from hard plastic. Suitable for Citroën 2CV, HY, 11CV. At the 2CV the knob was also installed for the headlight vertical adjustment.

Art.No.	Quality	needed qty
16468	4	1

**Citroën 2CV
Citroën HY + 11CV**

Knob for opening mechanism of the Ventilation shutter. Color cream, production from hard plastic. Suitable for Citroën 2CV, HY, 11CV. At the 2CV the knob was also installed for the headlight vertical adjustment.

Art.No.	Quality	needed qty
16470	4	1

1
2
3
4
5
6
7
8
9
10
11
12
13
14

0214 heating + ventilation

1
2
3
4
5
6
7
8
9
10
11
12
13
14



Knob for opening mechanism of the Ventilation shutter. Color grey, production from hard plastic. Suitable for Citroën 2CV, HY, 11CV. At the 2CV + AMI6 the knob was also installed for the headlight vertical adjustment.



Art.No.	Quality	needed qty
16284	4	1



Knob for opening mechanism of the Ventilation shutter. Color white, production from hard plastic. Suitable for Citroën 2CV, HY, 11CV. At the 2CV the knob was also installed for the headlight vertical adjustment.



Art.No.	Quality	needed qty
16466	4	1



Knob for opening mechanism of the Ventilation shutter. Color green, production from hard plastic. Suitable for Citroën 2CV, HY, 11CV. At the 2CV the knob was also installed for the headlight vertical adjustment.



Art.No.	Quality	needed qty
16471	4	1



Knob for opening mechanism of the Ventilation shutter. Color orange, production from hard plastic. Suitable for Citroën 2CV, HY, 11CV. At the 2CV the knob was also installed for the headlight vertical adjustment.



Art.No.	Quality	needed qty
16469	4	1



Knob for opening mechanism of the Ventilation shutter. Color red, production from hard plastic. Suitable for Citroën 2CV, HY, 11CV. At the 2CV the knob was also installed for the headlight vertical adjustment.



Art.No.	Quality	needed qty
16467	4	1



Knob for opening mechanism of the Ventilation shutter. Color black, production from hard plastic. Suitable for Citroën 2CV, HY, 11CV. At the 2CV + AMI6 the knob was also installed for the headlight vertical adjustment.



Art.No.	Quality	needed qty
16173	4	1



Knob round, colour grey, screwable, for heating adjustment and air distribution, bench lock. Reproduction made of metal! Suitable for Citroën 2CV, DS, HY.



Art.No.	Quality	needed qty
14526	3	



Knob round, colour black, screwable, for heating adjustment and air distribution. Reproduction made of metal! Suitable for Citroën 2CV, DS, HY.



Art.No.	Quality	needed qty
14527	3	



Knob round, chrome plated, screwable, for heating adjustment and air distribution. Reproduction made of metal! Suitable for Citroën 2CV, DS, HY.



Art.No.	Quality	needed qty
14528	1	



Radiator Fin Straightener. Designed for straightening fins and removing debris from vehicles radiators and air conditioning condensers. One tool with 6 different combs works on any vent or grill. The use of this tool allows the radiator or air conditioning grill to work correctly. Also use on air conditioning grills. Also suitable for oil and water radiators/condensers and evaporators.



Art.No.	Quality	needed qty
21039	1	1



Radiator hose (water hose), for inlet and outlet of the heater radiator (heat exchanger). Suitable for Citroën HY. Length: 1000mm. Inside diameter: 15mm.



Art.No.	Quality	needed qty
44830	3	3



Radiator hose universal. Inside diameter: 12,0-13,0mm. Outside diameter: 19,0-22,0mm. Length: 1000mm.



Art.No.	Quality	needed qty
72264	3	1



Ventilation shutter rubber (2 item). Suitable for Citroën HY, starting from year of construction 1964. Or. No. H644-70.



Art.No.	Quality	needed qty
44911	3	1



Collars clip strap with lock (made from metal). Overall length: about 500mm. Width: 5,0mm. These universal clip straps were in former times. Installed at many French car's. So also at radiator hoses, collar drive shafts etc.



Art.No.	Quality	needed qty
38271	3	



Nut for the handwheel of the headlight adjustment and the Ventilation shutter. Suitable for Citroën 2CV, HY, DS19.



Art.No.	Quality	needed qty
16602	2	2



Tube bending sleeve. Suitable for hose outer diameter of 12,5 > 13,4mm. Length: 60mm. With this you can easily produce bent water hoses. Simple and ingenious!



Art.No.	Quality	needed qty
72539	1	1



Tube bending sleeve. Suitable for hose outer diameter of 14,6 > 16,4mm. Length: 65mm. With this you can easily produce bent water hoses. Simple and ingenious!



Art.No.	Quality	needed qty
72540	1	1



Tube bending sleeve. Suitable for hose outer diameter of 16,5 > 18,4mm. Length: 70mm. With this you can easily produce bent water hoses. Simple and ingenious!



Art.No.	Quality	needed qty
72541	1	1



Tube bending sleeve. Suitable for hose outer diameter of 18,8 > 21,6mm. Length: 75mm. With this you can easily produce bent water hoses. Simple and ingenious!



Art.No.	Quality	needed qty
72542	1	1



Tube bending sleeve. Suitable for hose outer diameter of 21,8 > 24,6mm. Length: 90mm. With this you can easily produce bent water hoses. Simple and ingenious!



Art.No.	Quality	needed qty
72543	1	1



Hose clamp 11-17mm, especially for radiator hose. Vintage look. Embossed band with raised edges. This prevents the hose from being damaged. Small screw housing with 7mm hexagon head screw (with slot). Normal, modern hose clamps squeeze the hose. This is completely avoided with these clamps. And they even look better.



Art.No.	Quality	needed qty
50216	1	1



Hose clamp 13-20mm, especially for radiator hose. Vintage look. Embossed band with raised edges. This prevents the hose from being damaged. Small screw housing with 7mm hexagon head screw (with slot). Normal, modern hose clamps squeeze the hose. This is completely avoided with these clamps. And they even look better.



Art.No.	Quality	needed qty
50217	1	1



Hose clamp 15-24mm, especially for radiator hose. Vintage look. Embossed band with raised edges. This prevents the hose from being damaged. Small screw housing with 7mm hexagon head screw (with slot). Normal, modern hose clamps squeeze the hose. This is completely avoided with these clamps. And they even look better.



Art.No.	Quality	needed qty
50218	1	1



Hose clamp 19-28mm, especially for radiator hose. Vintage look. Embossed band with raised edges. This prevents the hose from being damaged. Small screw housing with 7mm hexagon head screw (with slot). Normal, modern hose clamps squeeze the hose. This is completely avoided with these clamps. And they even look better.



Art.No.	Quality	needed qty
50219	1	1



Hose clamp 22-32mm, especially for radiator hose. Vintage look. Embossed band with raised edges. This prevents the hose from being damaged. Small screw housing with 7mm hexagon head screw (with slot). Normal, modern hose clamps squeeze the hose. This is completely avoided with these clamps. And they even look better.



Art.No.	Quality	needed qty
50220	1	1



Hose clamp 26-38mm, especially for radiator hose. Vintage look. Embossed band with raised edges. This prevents the hose from being damaged. Small screw housing with 7mm hexagon head screw (with slot). Normal, modern hose clamps squeeze the hose. This is completely avoided with these clamps. And they even look better.



Art.No.	Quality	needed qty
50221	1	1



Hose clamp 32-44mm, especially for radiator hose. Vintage look. Embossed band with raised edges. This prevents the hose from being damaged. Small screw housing with 7mm hexagon head screw (with slot). Normal, modern hose clamps squeeze the hose. This is completely avoided with these clamps. And they even look better.



Art.No.	Quality	needed qty
50222	1	1

0214 heating + ventilation

1
2
3
4
5
6
7
8
9
10
11
12
13
14



38-50mm
Hose clamp 38-50mm, especially for radiator hose. Vintage look. Embossed band with raised edges. This prevents the hose from being damaged. Small screw housing with 7mm hexagon head screw (with slot). Normal, modern hose clamps squeeze the hose. This is completely avoided with these clamps. And they even look better.



Art.No.	Quality	needed qty
50223	1	



40-56mm
Hose clamp 40-56mm, especially for radiator hose. Vintage look. Embossed band with raised edges. This prevents the hose from being damaged. Small screw housing with 7mm hexagon head screw (with slot). Normal, modern hose clamps squeeze the hose. This is completely avoided with these clamps. And they even look better.



Art.No.	Quality	needed qty
50224	1	



50-65mm
Hose clamp 50-65mm, especially for radiator hose. Vintage look. Embossed band with raised edges. This prevents the hose from being damaged. Small screw housing with 7mm hexagon head screw (with slot). Normal, modern hose clamps squeeze the hose. This is completely avoided with these clamps. And they even look better.



Art.No.	Quality	needed qty
50225	1	



57-75mm
Hose clamp 57-75mm, especially for radiator hose. Vintage look. Embossed band with raised edges. This prevents the hose from being damaged. Small screw housing with 7mm hexagon head screw (with slot). Normal, modern hose clamps squeeze the hose. This is completely avoided with these clamps. And they even look better.



Art.No.	Quality	needed qty
50226	1	



15 - 20mm
hose clamp for 15-20mm.



Art.No.	Quality	needed qty
51020	3	



40 - 60mm
hose clamp for 40-60mm.



Art.No.	Quality	needed qty
51013	3	



Hose clamp Screwdriver hexagon (7mm). Flexible. Ideal for our hose clamps with raised edges.



Art.No.	Quality	needed qty
50227	1	



Universal radiator hose 90° sheet. Inside diameter: 15,0 + 16,0mm. Outside diameter: 25mm. Leg length 130 + 100mm.



Art.No.	Quality	needed qty
72348	3	1



End cap rubber. 10mm inside diameter. E.G., for plugging water pumps or heater radiator connections.



Art.No.	Quality	needed qty
32446	3	



End cap rubber. 12mm inside diameter. E.G., for plugging water pumps or heater radiator connections.



Art.No.	Quality	needed qty
32447	3	



End cap rubber. 14mm inside diameter. E.G., for plugging water pumps or heater radiator connections.



Art.No.	Quality	needed qty
32448	3	



End cap rubber. 16mm inside diameter. E.G., for plugging water pumps or heater radiator connections.



Art.No.	Quality	needed qty
32449	3	



End cap rubber. 18mm inside diameter. E.G., for plugging water pumps or heater radiator connections.



Art.No.	Quality	needed qty
32450	3	



End cap rubber. 21mm inside diameter. E.G., for plugging water pumps or heater radiator connections.



Art.No.	Quality	needed qty
32451	3	



End cap rubber. 23mm inside diameter. E.G., for plugging water pumps or heater radiator connections.



Art.No.	Quality	needed qty
32452	3	



End cap rubber. 26mm inside diameter. E.G., for plugging water pumps or heater radiator connections.



Art.No.	Quality	needed qty
32453	3	



End cap rubber. 8mm inside diameter. E.G., for plugging water pumps or heater radiator connections.



Art.No.	Quality	needed qty
32445	3	

Citroën DS + HY



Starter relay, mounted at the positive terminal of the battery. With 90cm cable. Suitable for Citroën DS (with left mounted battery) + Citroën HY. Or. No. 2D5401570T



Art.No.	Quality	needed qty
34071	3	1

Diesel 0,8 Bar



Oil pressure switch (Diesel). Thread M18 x 1,5. Suitable for Peugeot 204D, 304D, 305D, 404D, 504D, 505D, 604D. Citroën HY Diesel. Renault Diesel: R9, R11, R18, R20, R25, R30. Talbot Tagora Diesel. Response pressure: 0,8 bar. Or. No. 1131.10. Due to the design, there is always a drop of oil at the electrical connection. Alternatively, the modern oil pressure switch 70733 can be installed.



Art.No.	Quality	needed qty
71071	3	1

Citroën + Renault

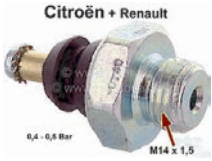

Oil pressure switch, suitable for Citroën ID19, DS19, HY petrol. Citroën 2CV + AMI6 without oil filters! Thread: M14x1,5.



Art.No.	Quality	needed qty
30049	2	1

Renault + Citroën

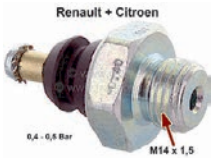

Oil pressure switch. Thread: M14 x 1,5. Response pressure: 0,5 bar. Suitable for Renault R3 + R4 (747cc), from year of construction 1962 to 1967. Renault Dauphine + Floride. Citroën HY petrol.



Art.No.	Quality	needed qty
81035	3	1

Peugeot Diesel
XD88, XD90, XD2, XD3
Citroën HY Diesel



Temperature switch coolant. 88°-75°. Thread: M22x1,5. Suitable for Peugeot diesel engines, XD88, XD90, XD2 XD3 (Peugeot 404, 505, 604, Citroën HY).



Art.No.	Quality	needed qty
72051	2	1



0216 cooling tube universal

1
2
3
4
5
6
7
8
9
10
11
12
13
14



10mm

End cap rubber. 10mm inside diameter. E.G., for plugging water pumps or heater radiator connections.



Art.No.	Quality	needed qty
32446	3	



21mm

End cap rubber. 21mm inside diameter. E.G., for plugging water pumps or heater radiator connections.



Art.No.	Quality	needed qty
32451	3	



12mm

End cap rubber. 12mm inside diameter. E.G., for plugging water pumps or heater radiator connections.



Art.No.	Quality	needed qty
32447	3	



23mm

End cap rubber. 23mm inside diameter. E.G., for plugging water pumps or heater radiator connections.



Art.No.	Quality	needed qty
32452	3	



14mm

End cap rubber. 14mm inside diameter. E.G., for plugging water pumps or heater radiator connections.



Art.No.	Quality	needed qty
32448	3	



26mm

End cap rubber. 26mm inside diameter. E.G., for plugging water pumps or heater radiator connections.



Art.No.	Quality	needed qty
32453	3	



16mm

End cap rubber. 16mm inside diameter. E.G., for plugging water pumps or heater radiator connections.



Art.No.	Quality	needed qty
32449	3	



8mm

End cap rubber. 8mm inside diameter. E.G., for plugging water pumps or heater radiator connections.



Art.No.	Quality	needed qty
32445	3	



18mm

End cap rubber. 18mm inside diameter. E.G., for plugging water pumps or heater radiator connections.



Art.No.	Quality	needed qty
32450	3	



www.cipere.fr

www.franzose.de

www.franzose.com

3

suspension + steering

wheel bearings	0301
front axle	0302
rear axle	0303
drive shaft	0304
drive shaft sleeves	0305
shock absorber - suspension balls	0306
suspension, spring struts, suspension cylinder	0307
tyres + rims	0308
sterring column - sterring wheel	0309
steering gear	0310
steering rods	0311
ignition locks	0312



A brand of **TOTAL** WHY CHOOSE ELF HTX CLASSIC CAR OIL?

TOTAL/elf has been the original equipment supplier for Citroën, Peugeot and Renault for more than 50 years. To protect automotive classics from damage caused by the use of modern oils, ELF has developed the HTX series. The unique HTX technology gives this engine oil optimum corrosion protection. In addition, the very good adhesion of the oil leads to a low-wear engine start even after longer downtimes. The ELF-HTX oils are compatible with standard and vintage car fuels as well as synthetic and non-synthetic oils.



Special oil for classic cars
with petrol engine
from 1950



Specific
motor oil for
high
performance
engines

5l
10196



Specific
motor oil
for classic cars
1900s - 1950s

20015



5l
20001

2l
10197

CITROËN

préfère

TOTAL



Lubricating grease, color red, 400g cartouche. Original one by TOTAL! Red lubricating grease was particularly developed for high-speed bearings (wheel bearings). Extremely acid-resistant! (Seawaters)



Art.No.	Quality	needed qty
20295	1	



Multi-purpose grease, cartridge 400g, suitable for our lubricating gun.



Art.No.	Quality	needed qty
20048	2	



Molybdenum universal grease in tube, 100g. High performance rolling bearing grease for lubricating wheel bearings, cardan joints etc.



Art.No.	Quality	needed qty
20291	3	

Citroën HY
1965 > 1982



avant + arrière
front + rear
vorne + hinten
90 x 45 x 50mm

Wheel bearing, suitable for Citroën HY, of year of construction 1965 to 1982. In front or rear fitting! Per piece. Outside diameter: 90,0mm. Inside diameter: 45,0mm. Overall height: 50,0mm



Art.No.	Quality	needed qty
43071	3	4

Citroën HY > 09/1966



arrière
rear
hinten

Wheel bearing set in the rear. Suitable for Citroën HY, to year of construction 09/1966. Wheel bearing: 90 x 45 x 50mm.



Art.No.	Quality	needed qty
48372	3	2

Citroën HY 09/1966 > 1981



arrière
rear
hinten

Wheel bearing set in the rear. Suitable for Citroën HY, of year of construction 09/1966 to 1981. Wheel bearing: 90 x 45 x 50mm.



Art.No.	Quality	needed qty
48370	3	2

Citroën HY > 09/1966



avant
front
vorne

Wheel bearing set in front. Suitable for Citroën HY, to year of construction 09/1966. Wheel bearing: 90 x 45 x 50mm.



Art.No.	Quality	needed qty
48371	3	2

Citroën HY 09/1966 > 1981



avant
front
vorne

Wheel bearing set in front. Suitable for Citroën HY, of year of construction 09/1966 to 1981. Wheel bearing: 90 x 45 x 50mm.



Art.No.	Quality	needed qty
48369	3	2

Citroën HY + 15CV



Locking plate, for the drive shaft nut. Suitable for Citroën HY + 15CV. Dimension: 30.5 x 54,0mm. Or. No. H41691



Art.No.	Quality	needed qty
48127	3	2

Citroën HY 09/1966 > 1981



Shaft seal outside, for the wheel bearing. Suitable for Citroën HY, starting from year of construction 09/1966 to 1981. Dimension: 54 x 72 x 10,0mm. Or. No. ZC 9612 540U



Art.No.	Quality	needed qty
48023	3	4

Citroën HY 09/1966 > 1981



Shaft seal inside, for the wheel bearing in front. Suitable for Citroën HY, of year of construction 09/1966 to 1981. 82mm outside diameter. Or. No. ZC 9612541U



Art.No.	Quality	needed qty
48024	3	2

Citroën HY > 09/1966



Shaft seal, for the wheel bearing. Suitable for Citroën HY, to year of construction 09/1966. Dimension: 55 x 72 x 10,0mm. Or. No. ZD 9219500U



Art.No.	Quality	needed qty
48368	3	4

Citroën HY > 09/1966



Shaft seal, for the wheel bearing. Suitable for Citroën HY, to year of construction 09/1966. Dimension: 55 x 82mm. Or. No. ZD 9219900U



Art.No.	Quality	needed qty
48373	3	4



0302 front axle

1
2
3
4
5
6
7
8
9
10
11
12
13
14



Distance ring, for the ball pin, at the front axle. Suitable for Citroën HY. Or. No. ZC9427126U. Made in Germany.



Art.No.	Quality	needed qty
48301	3	2



Distance disk 0,5mm, torsion bar (axle suspension). Suitable for Citroën HY + 15CV. Or. No. ZC9426905U + 426905



Art.No.	Quality	needed qty
44867	3	4



Adjusting nut for the lower ball pin at the wheel hub. Suitable for Citroën HY + 11CV. Thread: 40 x 150. Or. No. ZC 9441 190U + 441190. Made in Europe.



Art.No.	Quality	needed qty
44916	3	2



Multi-purpose grease, cartridge 400g, suitable for our lubricating gun.



Art.No.	Quality	needed qty
20048	2	



Molybdenum universal grease in tube, 100g. High performance rolling bearing grease for lubricating wheel bearings, cardan joints etc.



Art.No.	Quality	needed qty
20291	3	



Molykote grease in cartouche for lubricating gun. 400g (graphite grease). Heavy duty roller bearing grease for lubricating universal joints etc.. By the high proportion of Molykote is this grease also outstanding suitable for lubricating sliding fits from cardan shaft`s, ... Water-rejecting! Caution not for high-speed bearings (wheel bearings).



Art.No.	Quality	needed qty
20292	3	



Grease gun, for lubricating grease cartridge. Hobby quality!



Art.No.	Quality	needed qty
20047	4	1



Grease gun, for lubricating grease cartridge. Workshop quality from Liqui Moly!



Art.No.	Quality	needed qty
20563	2	1



Crown nut M18x1,5. Low design. E.G. for ball pin Citroën HY. Or. No. ZC9441 178U



Art.No.	Quality	needed qty
20999	3	



Ball pin repair set above. Suitable for Citroën HY. Length: 84mm. Or. No. ZC9441176U



Art.No.	Quality	needed qty
44819	3	2



Ball pin repair set down. Suitable for Citroën 15CV + Citroën HY. Length: 105mm. Or. No. 441177 + ZC9441177U



Art.No.	Quality	needed qty
60768	3	2



Balls (15 pieces) for the bearing seat of the torsion bar suspension. Suitable for Citroën HY. Diameter: 3,97mm. Per side are 15 balls mounted. Or. No. ZD 9411 200 U



Art.No.	Quality	needed qty
44878	3	2



Collar for the ball joint, at the wheel hub. Suitable for Citroën DS, SM + HY. Very good reproduction. Dimension about: 16x79mm. Or. No. ID 5410027F



Art.No.	Quality	needed qty
33147	1	4



Upper wishbone: Axle (with guide sleeve + nut), for the upper support arm of the front axle. Axle dimensions: 263 x 36mm. Suitable for Citroën HY + 15CV. Or. No. ZC9427082U + ZC9426959U + ZC9427082U. Made in Europe



Art.No.	Quality	needed qty
44917	3	2



Upper wishbone: Shim (0.5mm), for the upper front suspension arm of the front axle. Dimension 36.3 x 42mm. Suitable for Citroën HY. Or. No. ZC 9441 217 U



Art.No.	Quality	needed qty
44876	3	4



Upper wishbone: Shim (1.0mm), for the upper front suspension arm of the front axle. Dimension 36.3 x 45 x 1.0mm. Suitable for Citroën HY. Or. No. ZC 9441 218 U



Art.No.	Quality	needed qty
44877	3	4

Citroen HY

Wishbone washer for upper swing arm, HY.Or.Nr.ZC9427146U



Art.No.	Quality	needed qty
48191	3	2

Citroen HY + 15CV

Upper wishbone: Sleeve for axle, for the upper support arms of the front axle. Sleeve dimensions: 36,5 x 40 x 126mm. Suitable for Citroën HY + 15CV. Or. No. ZC9426959U. Made in Europe



Art.No.	Quality	needed qty
44918	3	2

Citroen HY

Upper wishbone: Silent bushing. Suitable for Citroën HY. Dimension: 56 x 38 x 36 x 47mm. Or. No. H4333



Art.No.	Quality	needed qty
48192	3	4

Citroen HY

Lower wishbone: Shim (0.1 mm), for the connecting axle between the lower support arms of the front axle. Suitable for Citroën HY. Or. No. ZC 9427 088 U



Art.No.	Quality	needed qty
44875	3	6

Citroën HY

NEW!

Lower wishbone shaft: Large repair kit for the lower wishbone shaft (splined shaft). Suitable for Citroën HY. Consisting of: 1 splined shaft (H 434-99A), 2 splined shaft sleeves, 2 silent block rubbers, press-in tool. The rubbers can be pressed in with a standard workshop press! On almost all HYs, the splines on the shaft are so rusted that the shaft splines in the sleeve skip. Reproduction Made in Germany.



Art.No.	Quality	needed qty
44931	3	1

Citroën HY

NEW!

Lower wishbone shaft: Repair kit, small, for the lower wishbone shaft (splined shaft). Suitable for Citroën HY. Consisting of: 2 splined shaft sleeves, 2 silent block rubbers, press-in tool. The rubbers can be pressed in with a standard workshop press! On almost all HYs, the splines on the shaft are so rusted that the shaft splines in the sleeve skip. Reproduction, Made in Germany.



Art.No.	Quality	needed qty
44930	3	1



Lubrication nipple cap from synthetic. Color: Red.



Art.No.	Quality	needed qty
12396	1	

M7

Lubricate nipple with M7 thread. Suitable for Citroën 2CV, DS, 11CV, HY, etc.



Art.No.	Quality	needed qty
12023	3	4



Lubrication nipple M8 x 1,25. (Taper lubrication nipple H1, straight). Wrench: 9,0mm.



Art.No.	Quality	needed qty
73607	3	5



Swing arm bearing outside. Suitable for Citroën HY. Outside diameter: 100,0mm. Inside diameter: 55,0mm. Width : 26,75mm.



Art.No.	Quality	needed qty
48209	2	4

Citroen HY

Swing arm bearing inside. Suitable for Citroën HY. Outside diameter: 80,0mm. Inside diameter: 40,0mm. Width : 24,75mm. Or. No. ZC9620006U



Art.No.	Quality	needed qty
48061	2	4



locking plate for the mounting from the ball pin, at the front axle. Suitable for Citroën HY. Or. No. ZC9441187U. Made in Germany.



Art.No.	Quality	needed qty
48300	3	2



Locking plate, for a ball joint at the front axle. Suitable for Citroën HY. Or. No. ZC9441181U. Per piece. Made in Germany.



Art.No.	Quality	needed qty
44827	3	2

Citroen HY

Shaft seal, for the radius arm bearing outside. Suitable for Citroën HY. Dimension: 72 x 100 x 12mm. Made in Germany.



Art.No.	Quality	needed qty
48025	3	4



Dust cap for ball pin. Suitable for Citroën HY. Or. No. ZC9427050U



Art.No.	Quality	needed qty
44820	3	2

HY

Locking cap down (27mm), in the rear, lower support arm. Suitable for Citroën HY. Or. No. 2480300U + ZD 9480 300 U.



Art.No.	Quality	needed qty
44874	3	2

1855-T
 Citroën HY + 15CV

Tool for the ball pin down (front axle). Citroën No: 1855-T. Suitable for Citroën HY + 15CV.



Art.No.	Quality	needed qty
44919	3	1

0303 rear axle
0304 drive shaft



Molykote grease in cartouche for lubricating gun. 400g (graphite grease). Heavy duty roller bearing grease for lubricating universal joints etc.. By the high proportion of Molykote is this grease also outstanding suitable for lubricating sliding fits from cardan shaft's, ... Water-rejecting! Caution not for high-speed bearings (wheel bearings).



Art.No.	Quality	needed qty
20292	3	4



Grease gun, for lubricating grease cartridge. Hobby quality!



Art.No.	Quality	needed qty
20047	4	1



Grease gun, for lubricating grease cartridge. Workshop quality from Liqui Moly!



Art.No.	Quality	needed qty
20563	2	1



Rubber stop round (conically), for the rear axle. Suitable for Citroën DS + SM. Citroën HY. Dimension: about 46,5x34mm. Or. No. 1D5404572Y



Art.No.	Quality	needed qty
32001	3	4



Lubrication nipple M8 x 1,25. (Taper lubrication nipple H1, straight). Wrench: 9,0mm.



Art.No.	Quality	needed qty
73607	3	5



Swing arm bearing outside. Suitable for Citroën HY. Outside diameter: 100,0mm. Inside diameter: 55,0mm. Width : 26,75mm.



Art.No.	Quality	needed qty
48209	2	4



Swing arm bearing inside. Suitable for Citroën HY. Outside diameter: 80,0mm. Inside diameter: 40,0mm. Width : 24,75mm. Or. No. ZC9620006U



Art.No.	Quality	needed qty
48061	2	4



Safety sheet, for the screwing of the anchor plate. Suitable for Citroën HY. Diameter: 8,5mm. Or. No. 1H5439153D. Made in Germany.



Art.No.	Quality	needed qty
48308	3	6



Shaft seal. for the radius arm bearing outside. Suitable for Citroën HY. Dimension: 72 x 100 x 12mm. Made in Germany.



Art.No.	Quality	needed qty
48025	3	4

0304 drive shaft



Drive shaft repair set, suitable for Citroën DS + HY. Without drive shaft collars! The needle bearing cups have a diameter of 34mm. Height of 14mm.



Art.No.	Quality	needed qty
33197	3	2



Drive shaft nut left (right-hand thread). Suitable for Citroën HY. Or. No. H4168D. Torque: 20mkg - 200NM. Made in Germany. We have modified the nut so that instead of a 38mm long nut now a common 36mm normal nut can be used.



Art.No.	Quality	needed qty
48126	3	1



Drive shaft nut right (left-hand thread). Suitable for Citroën HY. Or. No. H4168E. Torque: 20mkg - 200NM / Made in Germany. We have modified the nut so that instead of a 38mm long nut now a common 36mm normal nut can be used.



Art.No.	Quality	needed qty
48125	3	1



Lubricating grease, color red, 400g cartouche. Original one by TOTAL! Red lubricating grease was particularly developed for high-speed bearings (wheel bearings). Extremely acid-resistant! (Seawaters)



Art.No.	Quality	needed qty
20295	1	1



Multi-purpose grease, cartridge 400g, suitable for our lubricating gun.



Art.No.	Quality	needed qty
20048	2	1



Molykote grease in cartouche for lubricating gun. 400g (graphite grease). Heavy duty roller bearing grease for lubricating universal joints etc.. By the high proportion of Molykote is this grease also outstanding suitable for lubricating sliding fits from cardan shaft's, ... Water-rejecting! Caution not for high-speed bearings (wheel bearings).



Art.No.	Quality	needed qty
20292	3	1

0303 rear axle
0304 drive shaft

0 = New old stock
1 = Good
2 = Original
3 = Advanced replica
4 = Replica
5 = Mediocre replica



M9
M9, M9x1.25 flange nut. This M9 nut is somewhat poorly manufactured, but works well. Our M9 nuts 12123 are better.



Art.No.	Quality	needed qty
12074	4	



M9
M9, nut M9x1,25. Low (flatten) version. Amount: 5mm. E.g. for the valve cover screw connection on the 11CV with D-engine. Or. No. 2372-S



Art.No.	Quality	needed qty
12385	2	



M9 x 1,25
M9, nut M9x1,25. For example mounting drive shaft at the gearbox for 2CV. Amount: 9mm. Very good quality.



Art.No.	Quality	needed qty
12123	2	



M9 x 42mm
M9, stud bolt, for the mounting of the drive shaft at the gearbox. Suitable for Citroën 2CV + Citroën DS. Measurement: M9x42mm.



Art.No.	Quality	needed qty
12182	3	



M9
M9, washer. Dimension: 9.2 x 20 x 1,2mm.



Art.No.	Quality	needed qty
12386	2	



Citroën DS + HY
Nut, for the connector Tripodes aluminum casing. Suitable for Citroën DS + Citroën HY. Per piece. Dimension: M12 x 1,25 (collar unit). Or. No. ZC9615032U



Art.No.	Quality	needed qty
33191	3	12



Lubrication nipple cap from synthetic. Color: Red.



Art.No.	Quality	needed qty
12396	1	



M7
Lubricate nipple with M7 thread. Suitable for Citroën 2CV, DS, 11CV, HY, etc.



Art.No.	Quality	needed qty
12023	3	4



Locking plate, for the drive shaft securement at the gearbox. Suitable for Citroën HY. Or. No. ZC9409506U. Per piece. Made in Germany.



Art.No.	Quality	needed qty
44824	3	6



Citroën HY + 15CV
Locking plate, for the drive shaft nut. Suitable for Citroën HY + 15CV. Dimension: 30.5 x 54,0mm. Or. No. H41691



Art.No.	Quality	needed qty
48127	3	2



Shaft seal for the differential (drive shaft). Suitable for Citroën HY + Citroën 15CV. Dimension: 61 x 40 x 12,5mm. Material: Vitton!. Or. No. ZC96112645U.



Art.No.	Quality	needed qty
44832	1	2



M12x51
Stud bolt for the drive shaft. Dimension: M12x1,25 x 51. Suitable for Citroën DS + Citroën HY. Or. No. 1D5423871



Art.No.	Quality	needed qty
33192	3	12



Citroën DS + HY
Tripodes case, inclusive new balls. For the securement, of the drive shaft. Suitable for Citroën DS + Citroën HY. Or. No. 2D5430517J



Art.No.	Quality	needed qty
33194	3	2



0305 drive shaft sleeves

0306 shock absorber - suspension balls

1
2
3
4
5
6
7
8
9
10
11
12
13
14



Collar drive shaft gearbox side (for aluminum Tripodes case round). Suitable for Citroën DS + Citroën HY. Diameter: 85,5 + 32mm. Or. No. DS373-88

Art.No.	Quality	needed qty
33262	3	2



Collar drive shaft gearbox side (for aluminum Tripodes case round). Suitable for Citroën DS, from year of construction 9/1965 to 3/1970. Citroën HY. Diameter inside: 80 + 30,0mm. Or. No. DX373-88

Art.No.	Quality	needed qty
33198	3	2



Drive shafts collar gearbox side (for Tripode). Suitable for Citroën HY. Or. No. HY373299A

Art.No.	Quality	needed qty
48130	3	2



Drive shafts collar wheel side. Suitable for Citroën HY. Connection diameter: 30,0 + 90,0mm. Or. No. HY37399

Art.No.	Quality	needed qty
48131	3	2



Collar drive shaft, gearbox side. Suitable for Citroën DS, starting from year of construction 10/1969 + Citroën HY. For drive shafts Tripdes from steel. The collar has a triangular mounting.

Art.No.	Quality	needed qty
33142	1	2



Sheet jacket, for the drive shafts collar wheel side. Suitable for Citroën HY, 11CV, 15CV. Inside diameter: 91,0mm. Height: 90,0mm. Or. No. HY373-62 + 441369

Art.No.	Quality	needed qty
48132	3	2



Collars clip strap with lock (made from metal). Overall length: about 500mm. Width: 5,0mm. These universal clip straps were in former times installed at many French car's. So also at radiator hoses, collar drive shafts etc.

Art.No.	Quality	needed qty
38271	3	2



Pressure accumulator ball, LHM, reproduction. 400ccm, 62 bar. Suitable for Citroën ID-DS, BX, GSA, GS, CX, SM.

Art.No.	Quality	needed qty
32103	3	1



Shock absorber mounting, for lying (horizontal mounting) shock absorber. Suitable for Citroën HY, to year of construction 1963.

Art.No.	Quality	needed qty
48378	3	2



Rear shock absorber (2 pieces), horizontally mounted. Suitable for Citroën HY, until year of construction 11/1969. Length: 325-525mm. Mounting eye diameter: 14mm. Or. No. 3H5401855R

Art.No.	Quality	needed qty
48065	3	1



Rear shock absorber, vertical mounting (2 pieces). Suitable for Citroën HY, from year of construction 11/1969. length: 420-605mm. Mounting eye diameter: 14mm. Or. No. HY43602

Art.No.	Quality	needed qty
48062	3	1



Shock absorber in front (2 fittings), outside. Suitable for Citroën HY, starting from year of construction 11/1969. Overall length: 380mm. Securement eye: 17mm + 12mm. Or. No. HY43604

Art.No.	Quality	needed qty
48066	3	1



Shock absorber in front, outside (2 fittings). Suitable for Citroën HY, to year of construction 11/1969. Length: compressed 370mm. Pulled apart 580mm. Or. No. 2H5401853

Art.No.	Quality	needed qty
48063	3	1



Shock absorber in front, inside (2 fittings). Suitable for Citroën HY, to year of construction 11/1969. Length: compressed 270mm. Pulled apart 460mm. Or. No. 2H5401854

Art.No.	Quality	needed qty
48064	3	1



suspension, spring struts, suspension cylinder 0307

Vehicle height corrector repair set. Hydraulic system LHM. Suitable for Citroën DS + HY with hydraulic rear axle. Or. No. DS43502DR



Art.No.	Quality	needed qty
31121	3	2



Vehicle height corrector, in the exchange. Hydraulic system LHM (green liquid). Suitable for Citroën DS + SM. Citroën HY with hydraulic rear axle. Plus 100 Euro Old part deposit.



Art.No.	Quality	needed qty
31124	3	2



Ball joint socket (ball cup rear axle) collar, suitable for Citroën DS + Citroën SM. HY with hydraulic rear axle. Or. No. D43481 + 3D5412331K



Art.No.	Quality	needed qty
32101	3	2



Ball joint socket (ball cup) retaining clamp. Suitable for Citroën DS + Citroën SM. HY with hydraulic rear axle. Diameter hook: 3mm. Or. No. D434-80



Art.No.	Quality	needed qty
32160	3	2



Ball joint socket (ball cup) collar, protection ring (fixture ring from rubber). Suitable for Citroën DS. Or. No. D43463



Art.No.	Quality	needed qty
32130	3	2



Ball joint socket (ball cup) repair set. Suitable for Citroën DS, starting from year of construction 1965. HY with hydraulic rear axle. Consisting of: 1x ball, 1x sealing sleeve, 1x retaining clip.



Art.No.	Quality	needed qty
32127	4	2



Ball joint socket ball, rear. Suitable for Citroën DS, starting from year of construction 1965 + Citroën SM. HY with hydraulic rear axle. Diameter: 15,87mm. Or. No. ZD9410800U



Art.No.	Quality	needed qty
32159	3	2



Ball joint socket (ball cup), rear. Suitable for Citroën DS + Citroën SM. HY with hydraulic rear axle. Or. No. 5412334T



Art.No.	Quality	needed qty
32122	3	2



Suspension cylinder piston rod. Suitable for Citroën DS BREAK + HY. Or. No. DF4343. Length: 225mm.



Art.No.	Quality	needed qty
33178	3	2



Balls (15 pieces) for the bearing seat of the torsion bar suspension. Suitable for Citroën HY. Diameter: 3,97mm. Per side are 15 balls mounted. Or. No. ZD 9411 200 U



Art.No.	Quality	needed qty
44878	3	2



Collar ball joint wheel hub, suitable for Citroën DS, SM, HY. Reproduction. Dimension: about 16x79mm. Or. No. ID 5410027F



Art.No.	Quality	needed qty
32000	3	2



0308 tires + rims

Citroen HY



Label "air pressure" for tire 17x400. Suitable for Citroën HY.



Art.No.	Quality	needed qty
44884	3	2

Citroen HY



Label "air pressure" for tire 19x400. Suitable for Citroën HY.



Art.No.	Quality	needed qty
44885	3	2

Citroen HY



Rim 16 inch. Suitable for Citroën HY. These rims do not have TÜV permission, only for vehicles, which are not used in the public traffic. Production in the European Union. The new rim has the measurements of 5,5x16 " (137.7mm x 406,4mm). HY has normally rims with 400mm diameter. This original 400mm rims can't used with 16 " (406,4mm) (danger to jump off the tire from the rim). On the new 16 " rim the following tires (with hose) can be used: 195/75 R16C 107/105R, load 925 kg for each tire, speed of 170 kmh (suitable hose 12240) or 175/80 R 16 98/96Q, load 710 kg for each tire, speed of 160kmh (hose 12241).



Art.No.	Quality	needed qty
44879	3	4

Citroen HY



Wheel cover (hub cover, wheel lid). Suitable for Citroën HY. Made in Germany. A little thing, but if the original caps are no longer beautiful, adorn new hub caps the complete vehicle.



Art.No.	Quality	needed qty
44908	3	4

Citroen HY



Wheel nut. Suitable for Citroën HY, starting from year of construction 04/1970. Or. No. HY471-178A. Thread: M16



Art.No.	Quality	needed qty
48353	3	20



The brake-down aid for on the road. SONAX TyreFix restores driveability to flat tyres, without tyre change. Seals small holes in the tyre and pumps it up. Practical, fast and safe. 400ml



Art.No.	Quality	needed qty
21024	3	1



Tire 17x400. Manufacturer Vredestein. Suitable for Citroën HY. Peugeot J7, 203 BREAK.



Art.No.	Quality	needed qty
12225	2	4



Innertube for tire size 17R400. Manufacturer Michelin. Suitable for Citroën HY + Peugeot J7.



Art.No.	Quality	needed qty
12241	2	4



Innertube for tire size 19R400. Manufacturer Michelin. Suitable for Citroën HY + Peugeot J7.



Art.No.	Quality	needed qty
12240	2	4

Adaptateur de valve de type TR13 à TR15
Tire valve adapter from TR13 to TR15
Reifenventiladapter von TR13 auf TR15



Tire valve adapter of TR13 (13mm) on TR15 (15mm). This adapter is required, if you have old rims, with 15mm hole for valves. New valves are always 13mm in the diameter.



Art.No.	Quality	needed qty
12361	3	4



Valve (rubber valve) for rim. Suitable for Citroën 2CV, DS, CX, HY, GS. Renault R4, R5, R6, R8, R10, rear engine. Peugeot 203, 403, 404, 504, 604, 204, 304, J7. For valve hole: 11,3mm. Length: 42,5mm.



Art.No.	Quality	needed qty
12208	3	5



Valve long (rubber valve) for rim. To uses this long valve, if the rim has a large wheel cover (with cutout for the valve). Suitable for Citroën DS, CX, HY, GS. Renault R4, R5, R6, R8, R10, rear engine. Peugeot 203, 403, 404, 504, 604, 204, 304, J7. For valve hole: 11,3mm. Length: 61,5mm.



Art.No.	Quality	needed qty
12412	3	5



Valve extractor + lifter (tire valve)



Art.No.	Quality	needed qty
20299	3	



Valve caps for the tire. With Citroën Logo. Set = 4 fittings!



Art.No.	Quality	needed qty
12312	4	1

1
2
3
4
5
6
7
8
9
10
11
12
13
14



Rubber bush (bearing) for the steering column above. Suitable for Citroën 11CV, 15CV, HY. Diameter top: 45,34mm. Diameter bottom: 42,34mm. Or. No. 602169



Art.No.	Quality	needed qty
60228	3	1



Bearing bush with rubber, for the steering column at the top. Suitable for Citroën 11CV + 15CV. Citroën HY, to year of construction 1965. Dimension: 36,7 x 22,5 x 30mm. Or. No. 604129 + 604130



Art.No.	Quality	needed qty
60233	3	1



Steering gear bellow from rubber, suitable for Citroën HY.



Art.No.	Quality	needed qty
43131	3	2



Cover sheets (shielding plates) for the steering gear. Completely for in front + rear. Suitable for Citroën 11CV BN + HY. Or.Nr. 601980 + 601981



Art.No.	Quality	needed qty
60873	3	1



Locking plate, at the steering gear (closing sheet). Suitable for Citroën HY. Or. No. H442-68. Per piece. Made in Germany.



Art.No.	Quality	needed qty
44826	3	2



Spacer 0,3mm (3 item), for the lower steering gear case (between steering column bottom and steering gear). Suitable for Citroën HY. Or. Nr. HY442-81B



Art.No.	Quality	needed qty
48342	3	1



Bolt in the steering gear. (2x bolts, 3x seat shell). Repair kit, ball diameter 25mm. The bolts take up the tie rods. Suitable for Citroën 11CV + Citroën HY, from year of construction 1948 to 1965. Or. No. 601847, 601849, 601836



Art.No.	Quality	needed qty
60790	3	1



Ball pin (2x) with bearing shells (4x), for the steering gear. Suitable for Citroën HY, starting from year of construction 04/1969. Ball pin length: 84mm. Thread: M12 x 1,5. Or. No. HY442-100. Bearing shells diameters: 28mm. Amount: 11,7mm. Or. No. HY442-242A. Since the year of construction 05/1972, the bearing shells are installed.



Art.No.	Quality	needed qty
48322	3	1



0312 ignition locks



Bolt in the steering gear. (2x bolts, 3x seat shell). Repair kit, ball diameter 25mm. The bolts take up the tie rods. Suitable for Citroën 11CV + Citroën HY, from year of construction 1948 to 1965. Or. No. 601847, 601849, 601836



Art.No.	Quality	needed qty
60790	3	1

Citroën HY ZC9602046U



Rubber cap for the tie rod end. Suitable for Citroën HY. Or. No. ZC9602046U.



Art.No.	Quality	needed qty
48321	3	2



Steering gear bellow from rubber, suitable for Citroën HY.



Art.No.	Quality	needed qty
43131	3	2



Trakrite Wheel Alignment Gauge. Trakrite is the simplest, most accurate device for checking the alignment of the steered wheels of car and light commercials. It is a roller bearing platform over which one front wheel is slowly driven with the wheels in their straight ahead position.



Art.No.	Quality	needed qty
20501	3	1



Tie rod (per piece), without tie rod end. Length: 603mm. Suitable for Citroën HY, starting from year of construction 09/1967. The tie rods are on the left + on the right identically constructed. Or. No. HY443-1



Art.No.	Quality	needed qty
48341	3	2



Tie rod end repair set largely. Pin length: 74mm. Thread: M12 x 1,5. Suitable for Citroën HY, starting from year of construction 4/1969. Or. No. HY443-100 + ZC9601876U.



Art.No.	Quality	needed qty
48183	2	2



Tie rod end repair set small (pins with 2 bearing shells). Pin length: 74mm. Thread: M12 x 1,5. Suitable for Citroën HY, starting from year of construction 4/1969. Or. No. HY443-100 + ZC9601876U.



Art.No.	Quality	needed qty
48320	3	2

0311 steering rods



Citroën 2CV Mehari, HY 2CV old/Mehari/HY, door lock, lockcylinder set for old 2CV + Mehari, HY. 2x door lock (round pin) + 1x starter lock (angular pin)! With vehicles with starter button!



Art.No.	Quality	needed qty
16187	2	1



Ignition lock in the dashboard, for Citroën 2CV with starter button (with 2 connections). The ignition lock also fits in the Citroën DS until 1967, AMI6 and Citroën HY. Reproduction, incl. 2 keys.



Art.No.	Quality	needed qty
14236	4	1



Ignition lock in the dashboard, for Citroën 2CV with starter button (with 4 connections). The ignition lock also fits in the Citroën DS until 1967, AMI6 and Citroën HY. Reproduction, incl. 2 keys.



Art.No.	Quality	needed qty
16678	4	1



Starter lock in the dashboard. Suitable for Citroën 2CV + HY. Inclusive 2 keys. The lock has 2x mounting thread M5 x 0.80 (ISO standard metrically). In the old Citroën is often M5 x 0.75 installed. Use please 2 suitable screws!



Art.No.	Quality	needed qty
14613	3	1

Citroën 2CV, DS, HY



Ignition lock key blank, suitable for Citroën 2CV, DS, HY. (small version, ignition key has the size of door keys, for vehicles with starter button). Shaft length: 17,3mm. Shaft width: 7,0mm.



Art.No.	Quality	needed qty
14142	2	1

Citroën DS >1968 Citroën HY



Ignition lock, suitable for Citroën DS, up to year of construction 1968. Citroën HY. True to original reproduction. Or. No. DW21214C



Art.No.	Quality	needed qty
33188	3	1



4

brakes

wheel bearings	0401
front axle	0402
rear axle	0403
drive shaft	0404
drive shaft sleeves	
shock absorber - suspension balls	0405
suspension, spring struts, suspension cylinder	0406
tyres + rims	0407
sterring column - sterring wheel	0408
steering gear	0409
steering rods	0410
ignition locks	0411
	0412



Citroen HY

 Brake light switch (replacement). Suitable for Citroën HY.

Art.No.	Quality	needed qty
48397	3	1



Citroen 2CV, Dyane, DY, HY

 Stop light switch at the brake pedal. Connection flat plug. Connector: M12x1. Suitable for Citroën 2CV6, DS, CX, BX, HY, GS

Art.No.	Quality	needed qty
14127	3	1



Citroen HY 01/1973 >

 Stop light switch. Suitable for Citroën HY, to year of construction 01/1973. Original one, no reproduction (NOS). Or. No. HG576-02

Art.No.	Quality	needed qty
44011	1	1





 Spring for brake pedal + clutch pedal. Suitable for Citroën HY, Installed starting from year of construction 12/1969. Diameter: about 20mm. Length: about 155mm. 41 turns. Or. No. HY435-25. Note: With Citroën HY, from year of construction 12/1967 to 12/1969, is installed 1x spring article no. 48240 (ZC9089071u clutch) + 1x article no. 48292 (HY435-25 brake).

Art.No.	Quality	needed qty
48292	3	2





 Spring for brake pedal + clutch pedal. Suitable for Citroën HY, Installed up to year of construction 12/1967. Diameter: about 12mm. Length: about 220mm. 31 turns. Or.Nr. ZC9089071U. Note: With Citroën HY, from year of construction 12/1967 to 12/1969 is 1x the spring article no. 48293 (ZC9089071u clutch) + 1x article no. 48292 (HY435-25 brake) Installed.

Art.No.	Quality	needed qty
48293	3	2





 Spring for the clutch cable at the bottom. Suitable for Citroën HY. Or. No. H142-5.

Art.No.	Quality	needed qty
48240	3	1





 Foot throttle spring, suitable for Citroën HY, starting from year of construction 03/1963. Or. No. H142-14A

Art.No.	Quality	needed qty
48239	3	1



 Foot throttle spring, suitable for Citroën HY, of year of construction 05/1959 to 03/1963. Or. No. H142-14.

Art.No.	Quality	needed qty
48238	3	1





 Pedal rubber for Citroën 2CV with hanging pedals. The pedal rubber has a Citroën Logo. External dimensions: 66 x 45mm.

Art.No.	Quality	needed qty
18066	3	2



Citroën HY Citroën CX, Rosalie

 Pedal rubber oval, with Citroën emblem. Suitable for Citroën HY, C4, Rosalie.

Art.No.	Quality	needed qty
44010	3	2



0402 front brake without hydraulic parts



Brake shoes set in front (new parts). Suitable for Citroën HY, to year of construction 02/1962. Wide one: 45mm. Note: New parts, an old part return is not necessary! Made one in European Union. Or. No. HY451-018



Art.No.	Quality	needed qty
44814	3	1



Brake shoes set in front (new parts). Suitable for Citroën HY, starting from year of construction 02/1962. Width: 55mm. Note: New parts, an old part return is not necessary! Made in European Union. Or. No. HY451-018A



Art.No.	Quality	needed qty
44891	3	1



Bush (bearing) from bronze, for the brake shoes. Suitable for Citroën 11CV + HY. Dimension: 20 x 22 x 10mm. Or. No. 438314 + ZY9438656U. Note: For HY the bushes must be shortened on an height of 8,5mm (grind off).



Art.No.	Quality	needed qty
60501	3	8



Rivet for the brake shoe. Universal suitable e.g. for 11CV / 15CV / HY / 203 / 403 / Fregate etc. For Citroën 11CV/15CV, you require 92 pieces. Dimension: 4mm diameter. Shaft length 8mm.



Art.No.	Quality	needed qty
60437	3	



Retractor spring for the brake shoes (in front). Suitable for Citroën HY + Citroën 15CV. Dimension: 73 x 11mm. Or. No. 440531. Per piece



Art.No.	Quality	needed qty
60439	3	8



Safety sheet for the front brake system. Suitable for Citroën HY. Or. No. ZC9611001I. Made in Germany.



Art.No.	Quality	needed qty
44816	3	4



Toothed disk, dished, M7, outside diameter 14mm. (e.g. drum mounting, striker plate etc.)



Art.No.	Quality	needed qty
60650	3	24



rear wheel brake without hydraulic parts 0403



Brake shoes set rear (new parts). Suitable for Citroën HY. Or. No. HY451-50. Made in Europe.



Art.No.	Quality	needed qty
44030	3	1



Brake spring pliers for drum brake. 215mm long. One end grips on the brake lining, the other hooks onto the spring



Art.No.	Quality	needed qty
21061	3	1



Brake drum wear gauge. Used to measure the wear limit on brake drums as well as to measure the diameter of the drum and then set the shoe position prior to drum re-fitting. Max size drums 400mm diameter. Brake drum wear gauge. Size range 160mm-400mm. Selected steel. Measures drum wear. Metric and Imperial scale



Art.No.	Quality	needed qty
21065	3	1



Bush (bearing) from bronze, for the brake shoes. Suitable for Citroën 11CV + HY. Dimension: 20 x 22 x 10mm. Or. No. 438314 + ZY9438656U. Note: For HY the bushes must be shortened on an height of 8,5mm (grind off).



Art.No.	Quality	needed qty
60501	3	8



Rivet for the brake shoe. Universal suitable e.g. for 11CV / 15CV / HY / 203 / 403 / Fregate etc. For Citroën 11CV/15CV, you require 92 pieces. Dimension: 4mm diameter. Shaft length 8mm.



Art.No.	Quality	needed qty
60437	3	



Retract spring, for the brake shoes rear. Suitable for Citroën HY. Per piece! Overall length about 143mm. Diameter 10mm. Spring length about 70mm. Or.Nr. ZC9438770U



Art.No.	Quality	needed qty
48241	3	4



Retractor spring for the brake shoes (in front). Suitable for Citroën HY + Citroën 15CV. Dimension: 73 x 11mm. Or. No. 440531. Per piece



Art.No.	Quality	needed qty
60439	3	8



Safety sheet for the rear brake system. Suitable for Citroën HY. Or. No. ZC9088867U



Art.No.	Quality	needed qty
44815	3	4



Safety sheet, for the screwing of the anchor plate. Suitable for Citroën HY. Diameter: 8,5mm. Or. No. 1H5439153D. Made in Germany.



Art.No.	Quality	needed qty
48308	3	6



Toothed disk, dished, M7, outside diameter 14mm. (e.g. drum mounting, striker plate etc.)



Art.No.	Quality	needed qty
60650	3	24

www.franzose.com



0404 brake line prefabricated + hydraulic lines



Hydraulic pipe connector (to connect 3 pipes). For pipe with 4,5mm diameter. Thread: M9



Art.No.	Quality	needed qty
34599	3	



Brake pipe + hydraulic pipe connector, with sheet metal bracket to attaching. For pipe with 4,5mm diameter. Thread: 9mm.



Art.No.	Quality	needed qty
34598	3	



Hydraulic pipe connector (to connect 4 pipes). For pipe with 4,5mm diameter. Thread: M9.



Art.No.	Quality	needed qty
34607	3	1



Brake line + hydraulic line connector, for lines with 3,50mm diameters. Suitable for Citroën 2CV, Citroën DS, Citroën HY etc. The connector operates with cutting rings. No Brake line flaring tool are required! There are pipes with 3,50mm + 3,75mm diameter. For 3,75mm you require the connector 32349!



Art.No.	Quality	needed qty
32388	3	1



Brake pipe + hydraulic pipe connector. For pipe with 4,5mm diameter. Thread: 9mm thread! Or. No. 1D5426236B



Art.No.	Quality	needed qty
34604	3	



Brake line link (3 path link). Thread brake line connector: M9 (in front).



Art.No.	Quality	needed qty
13255	3	1



Brake line in front. Connection from brake hose to the wheel brake cylinder. Suitable for Citroën HY. Length: about 265mm. Diameter brake line: 6,35mm.



Art.No.	Quality	needed qty
44040	3	2



Brake line in front. Connection between the upper and the lower wheel brake cylinder. Suitable for Citroën HY.



Art.No.	Quality	needed qty
44041	3	2

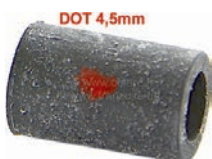

Brake hose seal DOT (red). For DOT brake system (normal brake fluid DOT4). 4,5mm line (connector M9). Suitable for Citroën 2CV + Citroën HY.



Art.No.	Quality	needed qty
13214	3	1



Brake pipe set. Citroën HY, to year of construction 1963. Diameter: 6,35mm. Material: Cupro-nickel (CuNifer)



Art.No.	Quality	needed qty
44900	3	1



Brake pipe set. Citroën HY, from year of construction 03/1963 to 12/1967. Material: Stainless steel



Art.No.	Quality	needed qty
44901	3	1



Brake pipe set. Citroën HY, from year of construction 12/1967 to 1975. Single circuit brake system. Material: Stainless steel



Art.No.	Quality	needed qty
44902	3	1



Brake pipe set. Citroën HY. Dual circuit brake assembly (tandem cylinder). Material: Stainless steel



Art.No.	Quality	needed qty
44903	3	1

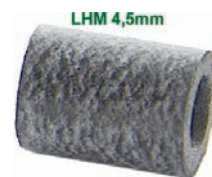

Brake hose seal + hydraulic line seal (socket) green. For LHM (hydraulic fluid green), 4,5mm line (connector 9mm). Suitable for Citroën DS, HY with hydraulics, GS, CX etc.



Art.No.	Quality	needed qty
13098	3	

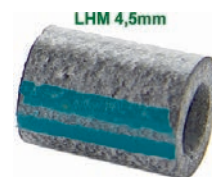

Hydraulic line + brake hose seal (socket) green. For LHM (green hydraulic fluid), 4,5mm line (connector 9mm). Very good reproduction. Suitable for Citroën DS, HY with hydraulic, GS, CX etc.



Art.No.	Quality	needed qty
33160	1	



Hydraulic line seal 6,35mm, for LHM (green) hydraulic system. 10mm outside diameter! About 10mm long. Suitable for Citroën DS, CX, GS, SM, BX, XM etc.



Art.No.	Quality	needed qty
32380	3	



Hydraulic hose rubber 4.5 mm LHS (red) + normal brake fluid DOT3 + DOT4. Top quality (new improved reproduction made from EPDM). Suitable for Citroën DS with LHS hydraulic system, Citroën HY + 2CV, AMI with 4.5 mm brake line (9 mm screw connection).



Art.No.	Quality	needed qty
32580	1	

brake lines + accessories, yard goods, universal 0405

1
2
3
4
5
6
7
8
9
10
11
12
13
14



Clinch screw 4,5mm, M9 thread. For Citroën hydraulic connectors.



Art.No.	Quality	needed qty
13096	3	



Brake + hydraulic line. Diameter: 7,95mm (5/16 inch). Length: 5 meter. Material: Kunifer (copper - nickel alloy, simple to bend. Kunifer does not rust). Clinch screws order separate!



Art.No.	Quality	needed qty
13158	3	1



Clinch screw, for 6.35mm hydraulic pipe. Thread: 12x1,25mm.



Art.No.	Quality	needed qty
34584	3	



Brake fluid DOT4. 1 liter. Manufacturer ATE. Suitable for all Citroën 2CV to year of construction 1981 (vehicles with drum brake in front). Citroën 11CV, HY. All Peugeot and Renault models.



Art.No.	Quality	needed qty
13026	2	1



Brake + hydraulic line (4,5mm) emergency repair set. Consisting of: 1 meter of Kunifer (copper - nickel) line. On 1 side flanged + Clinch screw. 2x high-speed link, 1x line seal 4,5mm. This repair set should always lie in the luggage compartment.



Art.No.	Quality	needed qty
13240	3	1



Brake fluid DOT4. 1/2 liter. Manufacturer TOTAL. Suitable for all Citroën 2CV to year of construction 1981 (vehicles with drum brake in front). Citroën 11CV, HY. All Peugeot and Renault models.



Art.No.	Quality	needed qty
13244	3	1



Brake + hydraulic line. Diameter: 4,5mm. Length: 25m. Material: Kunifer (copper - nickel alloy, simple to bend. Kunifer does not rust). Clinch screws order separate!



Art.No.	Quality	needed qty
13107	1	



Brake fluid DOT4. 5,0 liter can. Manufacturer TOTAL. Suitable for all Citroën 2CV to year of construction 1981 (vehicles with drum brake in front). Citroën 11CV, HY. All Peugeot and Renault models.



Art.No.	Quality	needed qty
13248	3	1



Brake + hydraulic line. Diameter: 4,5mm. Length: 7,62m. Material: Kunifer (copper - nickel alloy, simple to bend. Kunifer does not rust). Clinch screws order separate!



Art.No.	Quality	needed qty
13095	1	



Hydraulic pipe connector (to connect 3 pipes). For pipe with 4,5mm diameter. Thread: M9



Art.No.	Quality	needed qty
34599	3	



Brake + hydraulic line. Diameter: 4,75mm (3/16 inch). Length: 5m. Material: Kunifer (copper - nickel alloy, simple to bend. Kunifer does not rust). Clinch screws order separate!



Art.No.	Quality	needed qty
13155	3	



Brake pipe + hydraulic pipe connector, with sheet metal bracket to attaching. For pipe with 4,5mm diameter. Thread: 9mm.



Art.No.	Quality	needed qty
34598	3	



Brake + hydraulic line. Diameter: 6mm. Length: 5,0 meter. Material: Kunifer (copper - nickel alloy, simple to bend. Kunifer does not rust). Clinch screws order separate!



Art.No.	Quality	needed qty
13159	3	



Hydraulic pipe connector (to connect 4 pipes). For pipe with 4,5mm diameter. Thread: M9.



Art.No.	Quality	needed qty
34607	3	1



Brake + hydraulic line. Diameter: 6,35mm. Length: 5,0 meter. Material: Kunifer (copper - nickel alloy, simple to bend. Kunifer does not rust). Clinch screws order separate!



Art.No.	Quality	needed qty
13156	3	



Brake pipe + hydraulic pipe connector, for 4,5mm pipes. This connector operates with cutting rings. A brake pipe flaring machine is not necessary. Or. No. 1D5426236B



Art.No.	Quality	needed qty
32164	3	1

0405 brake lines + accessories, yard goods, universal

3,50mm



Brake line + hydraulic line connector, for lines with 3,50mm diameters. Suitable for Citroën 2CV, Citroën DS, Citroën HY etc. The connector operates with cutting rings. No Brake line flaring tool are required! There are pipes with 3,50mm + 3,75mm diameter. For 3,75mm you require the connector 32349!



Art.No.	Quality	needed qty
32388	3	1

3,75mm



Brake line + hydraulic line connector, for lines with 3,75mm diameters. Suitable for Citroën 2CV, Citroën DS, Citroën HY etc. The connector operates with cutting rings. No Brake line flaring tool are required! There are pipes with 3,75mm diameter. For 3,50mm you require the connector 32388!



Art.No.	Quality	needed qty
32349	3	1

4,75mm



Brake line + hydraulic line connector, for lines with 4,75mm diameter. Suitable for Citroën 2CV, Citroën DS, Citroën HY etc. The connector operates with cutting rings. No Brake line flaring tool are required!



Art.No.	Quality	needed qty
32348	3	1

6,35mm



Brake line + hydraulic line connector, for lines with 6,35mm diameter. Suitable for Citroën 2CV, Citroën DS, Citroën HY etc. The connector operates with cutting rings. No Brake line flaring tool are required!



Art.No.	Quality	needed qty
32350	3	1



Brake pipe + hydraulic pipe connector. For pipe with 4,5mm diameter. Thread: 9mm thread! Or. No. 1D5426236B



Art.No.	Quality	needed qty
34604	3	1

DOT 4,5mm



Brake hose seal DOT (red). For DOT brake system (normal brake fluid DOT4). 4,5mm line (connector M9). Suitable for Citroën 2CV + Citroën HY.



Art.No.	Quality	needed qty
13214	3	1



Brake line wrench. 10mm + 11mm. Workshop quality.



Art.No.	Quality	needed qty
20055	3	1



Brake line wrench. 8mm + 9mm. Workshop quality.



Art.No.	Quality	needed qty
20075	3	1

M10 x 1



Tap drill M10x1. (M10x1 was very often used with brake hoses). Manual cut tap drill!



Art.No.	Quality	needed qty
20944	3	1

M11 x 1



Manual cut tap drill M11x1



Art.No.	Quality	needed qty
20945	3	1



Hook set, 135 mm long. 4 pieces, ideal for removing O-rings, seals, Citroën brake line seals, etc. Contents: 1x straight tip, 1x 90° tip, 1x hook tip, 1x piercing tool.



Art.No.	Quality	needed qty
20902	3	1

LHM 4,5mm



Brake hose seal + hydraulic line seal (socket) green. For LHM (hydraulic fluid green), 4,5mm line (connector 9mm). Suitable for Citroën DS, HY with hydraulics, GS, CX etc.



Art.No.	Quality	needed qty
13098	3	1

LHM 4,5mm

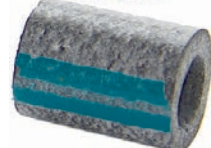

Hydraulic line + brake hose seal (socket) green. For LHM (green hydraulic fluid), 4,5mm line (connector 9mm). Very good reproduction. Suitable for Citroën DS, HY with hydraulic, GS, CX etc.



Art.No.	Quality	needed qty
33160	1	1



Hydraulic line Brake line flaring tools for use at the vehicle (to use at the car). For all flanging! For all Citroën lines with 3,5mm, 4,5mm + 6,35mm (1/4 "). For all lines after DIN/CSAE, for flanges of the types CD, E, F, F180 in the usual quantities 4,75mm, 6mm, 8mm, 9mm and 10mm.



Art.No.	Quality	needed qty
20938	1	1

LHM 6,35



Hydraulic line seal 6,35mm, for LHM (green) hydraulic system. 10mm outside diameter! About 10mm long. Suitable for Citroën DS, CX, GS, SM, BX, XM etc.



Art.No.	Quality	needed qty
32380	3	1

L: 10mm

Citroën DS
HY, 2CV, AMI

Hydraulic hose rubber 4.5 mm LHS (red) + normal brake fluid DOT3 + DOT4. Top quality (new improved reproduction made from EPDM). Suitable for Citroën DS with LHS hydraulic system, Citroën HY + 2CV, AMI with 4.5 mm brake line (9 mm screw connection).



Art.No.	Quality	needed qty
32580	1	1

0 = New old stock
1 = Good
2 = Original

3 = Advanced replica
4 = Replica
5 = Mediocre replica

brake lines + accessories, yard goods, universal 0405

LHM 6,35



L: 8mm

Hydraulic line rubber 6,35mm, LHM (green), 10mm outside diameter! About 8mm long. Suitable for Citroën DS, CX, GS, SM, BX, XM etc.



Art.No.	Quality	needed qty
32154	3	1

LHS 6,35

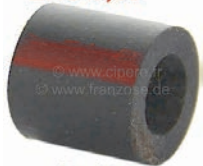

D: 10mm

Hydraulic line rubber 6,35mm, LHS (red). 10mm outside diameter! Suitable for Citroën DS, with LHS hydraulic system.



Art.No.	Quality	needed qty
32156	3	1

LHS 6,35



D: 12mm

Hydraulic line rubber 6,35mm, LHS (red). 12mm outside diameter. About 10mm long. Only suitable for Citroën DS, with LHS hydraulic system. This heavy rubber is for the connection at the brake system accumulator. Or. No. D392-9020



Art.No.	Quality	needed qty
32276	3	1



3 > 22mm

Pipe cutting equipment for brake hoses!



Art.No.	Quality	needed qty
20942	3	1



Universal protective rubber (e.g. for protecting electric cables, brake lines, brake hoses, handbrake cables, speedometer cables, petrol hose... External dimensions: 23x30mm. Inner diameter: 8mm. The rubber is slit on one long side, and can therefore be easily placed over the cable to be protected!



Art.No.	Quality	needed qty
83441	3	1

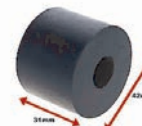

Universal protective rubber (e.g. for protecting electric cables, handbrake cables, petrol hose... External dimension: 42mm. Length: 31mm. Inner diameter: 12mm. The rubber is not slit (but of course this can be done afterwards if it makes assembly easier)



Art.No.	Quality	needed qty
83442	3	1



0406 brake hoses



Connection adapter (front) for connecting brake hose to wheel brake cylinder. External thread: 7/16 x 20 UNF. Internal thread: 11/16 x 16 UNF. Suitable for Citroën 11CV + 15CV, HY. Dimension: 22 x 32mm. Or. No. 438359



Art.No.	Quality	needed qty
60434	3	2



Brake hose at the rear left. Suitable for Citroën HY, of year of construction 1963 to 1969. Or. No. HY45356C. Made in France



Art.No.	Quality	needed qty
44062	3	2



Brake hose rear on the right. Suitable for Citroën HY, of year of construction 1963 to 1969. Or. No. HY45356B. Made in France



Art.No.	Quality	needed qty
44063	3	2



Brake hose rear, suitable for Citroën HY, to year of construction 1963. Length: 380mm. Thread: 11/16 - 18.



Art.No.	Quality	needed qty
44821	3	2



Brake hose rear. Suitable for Citroën HY, starting from year of construction 1970. Overall length: 340mm. Or. No. HY45333A. Made in France



Art.No.	Quality	needed qty
44061	3	2



Brake hose copper sealing ring. Dimension: 10 x 16 x 1mm.



Art.No.	Quality	needed qty
13085	3	



Brake hose copper sealing ring. Dimension: 12 x 18 x 1,5mm.



Art.No.	Quality	needed qty
13083	3	



Brake hose copper sealing ring. Dimension: 14 x 18 x 1,5mm.



Art.No.	Quality	needed qty
13084	3	

Citroën HY >1964
Citroën 15CV

Brake hose in front. Suitable for Citroën 15CV. Citroën HY, to year of construction 1964. Length: 360mm. Or. No. 520605. Made in France



Art.No.	Quality	needed qty
48035	3	2



Brake hose in front. Suitable for Citroën HY, of year of construction 1963 to 1972. Overall length: 330mm. Or. No. HY453-27A. Made in France



Art.No.	Quality	needed qty
44060	3	2



Nut M10x1. Flat design. For fastening brake hoses.



Art.No.	Quality	needed qty
21036	3	



Nut M12x1,5. Flat design. For fastening brake hoses.



Art.No.	Quality	needed qty
21037	3	



main brake cylinder 0407



Brake fluid reservoir from glass. Glass height: about 115mm. Inclusive fixture from high-grade steel. Suitable for Citroën 11CV + Citroën HY.



Art.No.	Quality	needed qty
60834	3	1



Cap for a brake fluid reservoir from glass. Thread about 44mm. Suitable for Citroën 11CV, 2CV, HY, Panhard, Peugeot 203, 403, 404.



Art.No.	Quality	needed qty
60539	3	1



Brake fluid reservoir connection rubber. For the connection from the glass container to the master brake cylinder. Dimension: Diameter above: about 20-21mm. Diameter down: about 12mm. Inside diameter down: 6.0mm. This system of the securement was used by many france classic car's. E.G. Citroën 11CV + 15CV, Citroën HY, Citroën Ami. Peugeot + Renault.



Art.No.	Quality	needed qty
60307	3	1



Master brake cylinder repair set (only seals), dual circuit brake system. Suitable for Citroën HY, starting from year of construction 1976. Made in France



Art.No.	Quality	needed qty
44071	4	1



Brake fluid reservoir connection rubber. For the connection from the glass container to the master brake cylinder. Dimension: Diameter above: about 20-21mm. Diameter down: about 12mm. Inside diameter down: 8.0mm. This system of the securement was used with many französichen car. E.G. Citroën 11CV + 15CV, Citroën HY, Citroën Ami. Peugeot + Renault.



Art.No.	Quality	needed qty
60881	3	1



Master brake cylinder dual circuit brake system. Suitable for Citroën HY, starting from year of construction 1976. Piston diameter: 25,4mm. Made in France



Art.No.	Quality	needed qty
44072	3	1



Master brake cylinder, 1 inch (25,4mm) piston. Suitable for Citroën 11CV + 15CV. Citroën HY. Renault Fregate, Juva 4. Simca Vedette, Regence, Versailles to year of construction 7/1955. Made in Europe.



Art.No.	Quality	needed qty
43007	3	1



Brake power controller, spring set. Suitable for Citroën HY, starting from year of construction 9/1966. Consisting of 3 springs. Or. No. HY456-291A, HY456-96, HY456-95.



Art.No.	Quality	needed qty
44075	3	1



Hollow bolt for master brake cylinder Citroën 11CV, HY, Peugeot 203. The screw comes at the front side into the master brake cylinder and takes up the distributor for the brake hoses. Thread 1/2 x 20 UNF. For 15mm connection diameter. Length without bolt head = 29mm.



Art.No.	Quality	needed qty
60805	3	1



Brake power controller (new part). Suitable for Citroën HY. Or. No. HY456-37.



Art.No.	Quality	needed qty
48337	3	1



Collar for the master brake cylinder (for 1 inch (25,4mm) master brake cylinder). Suitable for Citroën 11CV to year of construction 07/1952. Citroën HY. Citroën 2CV. Peugeot P203. Renault Fregate etc. Dimension: 36 x 54mm.



Art.No.	Quality	needed qty
60438	3	1



Brake power controller gasket kit. Suitable for Citroën HY.



Art.No.	Quality	needed qty
48343	3	1



Brake cylinder paste. Manufacturer: FÖRCH. 5g brake cylinder paste for hydraulic brake systems. For lubricating cylinder liners and pistons. Extends the service life of brake cylinders. Protects against corrosion. Compatible with DOT 3, DOT 4 and DOT 5.1 brake fluids. Keeps sleeves soft. Supports the installation of O-rings, lip seals, sleeves and other sealing elements made of rubber-elastic materials. Apply brake cylinder paste thinly and evenly on the surfaces to be lubricated. Attention: If you are installing a new wheel brake cylinder in your classic car, please coat the pistons and sleeves with this paste before installation. This will increase the longevity of the new brake parts on cars that are driven occasionally.



Art.No.	Quality	needed qty
84266	1	1



Reduction adapter from 1/2 UNF to 3/8 UNF. For Hydrovac!



Art.No.	Quality	needed qty
74561	3	2

0408 wheel brake cylinder rear



Brake power controller, spring set. Suitable for Citroën HY, starting from year of construction 9/1966. Consisting of 3 springs. Or. No. HY456-291A, HY456-96, HY456-95.



Art.No.	Quality	needed qty
44075	3	1



Brake power controller (new part). Suitable for Citroën HY. Or. No. HY456-37.



Art.No.	Quality	needed qty
48337	3	1



Brake power controller gasket kit. Suitable for Citroën HY.



Art.No.	Quality	needed qty
48343	3	1



Brake cylinder paste. Manufacturer: FÖRCH. 5g brake cylinder paste for hydraulic brake systems. For lubricating cylinder liners and pistons. Extends the service life of brake cylinders. Protects against corrosion. Compatible with DOT 3, DOT 4 and DOT 5.1 brake fluids. Keeps sleeves soft. Supports the installation of O-rings, lip seals, sleeves and other sealing elements made of rubber-elastic materials. Apply brake cylinder paste thinly and evenly on the surfaces to be lubricated. Attention: If you are installing a new wheel brake cylinder in your classic car, please coat the pistons and sleeves with this paste before installation. This will increase the longevity of the new brake parts on cars that are driven occasionally.



Art.No.	Quality	needed qty
84266	1	1



Sealing set wheel brake cylinder rear (1.1/8 inch = 28,5mm). Suitable for Citroën HY, starting from year of construction 1969.



Art.No.	Quality	needed qty
44809	3	2



Sealing set wheel brake cylinder rear (7/8 inch = 22,2mm). Suitable for Citroën HY, of year of construction 1963 to 1968. Renault Estafette, starting from year of construction 1967. Renault R16.



Art.No.	Quality	needed qty
44810	3	2



Wheel brake cylinder rear (on the left + on the right fitting). Per piece. Suitable for Citroën HY, starting from year of construction 12/1967. Citroën 15CV, with hydraulic suspension! Piston diameter: 28,6mm. Brake line connector: M9. Mounting board bore: 36mm. Length over everything: 70mm. Or. No. HY453-05B. Made in France



Art.No.	Quality	needed qty
44082	3	2



Wheel brake cylinder rear (on the left + on the right fitting). Per piece. Suitable for Citroën HY, of year of construction 10/1958 to 6/1963. Piston diameter: 22,2mm. Brake line connector: 7/16 x 20 UNF. Mounting board bore: 36mm. Length over everything: 68mm. Or. No. HY453-05. Made in France



Art.No.	Quality	needed qty
44080	4	2



Wheel brake cylinder rear (on the left + on the right fitting). Per piece. Suitable for Citroën HY, of year of construction 10/1958 to 6/1964. Piston diameter: 19,0mm. Brake line connector: 7/16 x 20 UNF. Mounting board bore: 36mm. Length over everything: 68mm. Or. No. HY453-05c. Made in France



Art.No.	Quality	needed qty
44083	3	2



Rear wheel brake cylinder (left + right, suitable). Per piece. Suitable for Citroën HY, from year of construction 1948 to 1958 (H 1200kg). HZ from year of construction 1949 to 1963 (HZ 850 kg). Piston diameter: 19 mm piston. Brake line connection: 7/16 x 20 UNF. Anchor plate bore: 36 mm. Overall length: 64 mm! Made in France



Art.No.	Quality	needed qty
48217	3	2



Wheel brake cylinder rear (on the left + on the right fitting). Per piece. Suitable for Citroën HY, of year of construction 7/1963 to 12/1967. Piston diameter: 22,2mm. Brake line connector: M9. Mounting board bore: 36mm. Length over everything: 68mm. Or. No. HY453-05A. Made in France



Art.No.	Quality	needed qty
44081	3	2



Wheel brake cylinder rear, suitable for Citroën HY, of year of construction 6/1963 to 12/1967. Piston diameter: 19mm. Brake line connector: M9x1,25. Mounting board bore: 36mm. Length over everything: 68mm. Or. No. HY45305D. Made in France



Art.No.	Quality	needed qty
44084	3	2

wheel brake cylinder rear 0408

0410 hand brake cable



Wheel brake cylinder repair set rear. Suitable for Citroën HY, of year of construction 1948 to 1963. Piston diameter: 19,0mm! Made in France



Art.No.	Quality	needed qty
48218	3	2



Dust cap from rubber, for the vent screw at brake calipers and wheel brake cylinders. Universal suitable for Citroën, Peugeot, Renault.



Art.No.	Quality	needed qty
13082	3	



Dust cap wheel brake cylinder, for piston diameters: 3/4 inch (19,05mm). Suitable for Citroën HY. Also universal fitting for other vehicles! Made in France



Art.No.	Quality	needed qty
44089	4	2



Dust cap wheel brake cylinder, for piston diameters: 7/8 inch (22,25mm). Suitable for Citroën HY, 11CV, 15CV, 2CV. Also universal fitting for other vehicles! Made in France



Art.No.	Quality	needed qty
44090	4	2



Hand brake cable on the left. Suitable for Citroën HY, to year of construction 1962. Length: 2090,0mm. Or. No. H4541B



Art.No.	Quality	needed qty
48053	3	1



Hand brake cable on the right. Suitable for Citroën HY, to year of construction 1962. Length: 2280,0mm. The hand brake cable has a lubrication nipple! Or. No. H4541C



Art.No.	Quality	needed qty
48054	3	1



Hand brake cable, on the left + on the right fitting. Suitable for Citroën HY, starting from year of construction 1963. Or. No. 5490010



Art.No.	Quality	needed qty
48056	3	2



Hand brake cable, on the left + on the right fitting. Suitable for Citroën HY, to year of construction 1962. Length: 1210,0mm. Socket length: 920,0mm. Or. No. HY4541A



Art.No.	Quality	needed qty
48055	3	2



Universal protective rubber (e.g. for protecting electric cables, brake lines, brake hoses, handbrake cables, speedometer cables, petrol hose... External dimensions: 23x30mm. Inner diameter: 8mm. The rubber is slit on one long side, and can therefore be easily placed over the cable to be protected!



Art.No.	Quality	needed qty
83441	3	

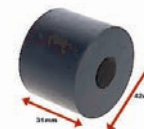

Universal protective rubber (e.g. for protecting electric cables, handbrake cables, petrol hose... External dimension: 42mm. Length: 31mm. Inner diameter: 12mm. The rubber is not slit (but of course this can be done afterwards if it makes assembly easier)



Art.No.	Quality	needed qty
83442	3	



0412 wheel brake cylinder front



Connection adapter (front) for connecting brake hose to wheel brake cylinder. External thread: 7/16 x 20 UNF. Internal thread: 11/16 x 16 UNF. Suitable for Citroën 11CV + 15CV, HY. Dimension: 22 x 32mm. Or. No. 438359



Art.No.	Quality	needed qty
60434	3	2



Brake cylinder paste. Manufacturer: FÖRCH. 5g brake cylinder paste for hydraulic brake systems. For lubricating cylinder liners and pistons. Extends the service life of brake cylinders. Protects against corrosion. Compatible with DOT 3, DOT 4 and DOT 5.1 brake fluids. Keeps sleeves soft. Supports the installation of O-rings, lip seals, sleeves and other sealing elements made of rubber-elastic materials. Apply brake cylinder paste thinly and evenly on the surfaces to be lubricated. Attention: If you are installing a new wheel brake cylinder in your classic car, please coat the pistons and sleeves with this paste before installation. This will increase the longevity of the new brake parts on cars that are driven occasionally.



Art.No.	Quality	needed qty
84266	1	1



Sealing sleeve, for a wheel brake cylinder piston (1.1/8 inch = 28,56mm). Suitable for Citroën HY. Also universal fitting for other vehicles!



Art.No.	Quality	needed qty
44085	4	4



Sealing sleeve, for a wheel brake cylinder piston (19,0mm). Suitable for Citroën HY. Also universal fitting for other vehicles!



Art.No.	Quality	needed qty
44086	4	4



Sealing sleeve, for a wheel brake cylinder piston (7/8 inch = 22,19mm). Suitable for Citroën HY. Also universal fitting for other vehicles!



Art.No.	Quality	needed qty
44087	3	4



Wheel brake cylinder repair set, in front. Suitable for Citroën HY + Citroën 15CV. For vehicles with 4 wheel brake cylinders in front! Piston diameter: 31,75mm (often as 32mm indicates). Made in France



Art.No.	Quality	needed qty
48216	3	4



Wheel brake cylinder set (4 pieces), for the front axle. Suitable for Citroën HY. Made in France



Art.No.	Quality	needed qty
48334	3	1



Wheel brake cylinder in front on the left, above. Suitable for Citroën HY + Citroën 15CV. Piston diameter: 32,0mm. Brake line connector: M12x1mm. Or. No. 620004.



Art.No.	Quality	needed qty
48036	3	1



Wheel brake cylinder in front on the left, down. Suitable for Citroën HY + Citroën 15CV. Piston diameter: 32,0mm. Brake line connector: M12x1mm. Or. No. 620004A.



Art.No.	Quality	needed qty
48037	3	1



Wheel brake cylinder in front on the right, above. Suitable for Citroën HY + Citroën 15CV. Piston diameter: 32,0mm. Brake line connector: M12x1mm. Or. No. 620004B.



Art.No.	Quality	needed qty
48038	3	1



Wheel brake cylinder in front on the right, down. Suitable for Citroën HY + Citroën 15CV. Piston diameter: 32,0mm. Brake line connector: M12x1mm. Or. No. 620004C.



Art.No.	Quality	needed qty
48049	3	1



Dust cap from rubber, for the vent screw at brake calipers and wheel brake cylinders. Universal suitable for Citroën, Peugeot, Renault.



Art.No.	Quality	needed qty
13082	3	



Dust cap, for the large wheel brake cylinders in front (31,75mm). Suitable for Citroën 15CV + HY.



Art.No.	Quality	needed qty
44073	3	4



5

electric + dashboard

cable tree	0501
cable tree accessories	0502
illuminant (light bulbs) 12 volt	0503
dashboard + accessories (control	0504
instruments inside)	0505
speedometer cable	0506
battery + holder	0507
headlights + accessories + holder	0508
turn signal, indoor lighting	0509
rear lighting	0511
washing system	0512
electrical component parts, other	0513
radio	0514
ignition lock	

1
2
3
4
5
6
7
8
9
10
11
12
13
14

3600 m²
Store with 3 floors
more than 2.700.000 articles
over 21.000 various items
over 2.800 articles from inhouse production



Der Franzose



www.cipere.fr

www.franzose.de

www.franzose.com





Citroën HY Indenor Diesel
Main cable harness, without tail cable harness. Suitable for Citroën HY Indenor Diesel. Made in Germany.



Art.No.	Quality	needed qty
48398	3	1



Main cable harness, without tail cable harness. Suitable for Citroën HY, from year of construction 09/1964 to 1970 (round switches in the dashboard). Made in Germany.



Art.No.	Quality	needed qty
48164	3	1



Main cable harness, without tail cable harness. Suitable for Citroën HY, from year of construction 1947 to 09/1964. Made in Germany.



Art.No.	Quality	needed qty
48276	3	1



Main cable harness, without tail cable harness. Suitable for Citroën HY, from year of construction 1970 to 1981 (square switches in the dashboard). Made in Germany.



Art.No.	Quality	needed qty
48165	3	1



Tail cable harness, on the left + on the right. Suitable for Citroën HY, short (L1) wheel base, extended rear overhang. For all years of construction. Made in Germany.



Art.No.	Quality	needed qty
48277	3	1



Tail cable harness, on the left + on the right. Suitable for Citroën HY, long (L2) wheel base + extended rear overhang. For all years of construction. Made in Germany.



Art.No.	Quality	needed qty
48279	3	1



Tail cable harness, on the left + on the right. Suitable for Citroën HY, normal (C) wheel base. For all years of construction. Made in Germany.



Art.No.	Quality	needed qty
48278	3	1



19mm
Isolation tape with fabric surface. This adhesive tape has been specially manufactured for cable harnesses. Vintage-style cotton fabric appearance, making it visually compatible with historical cable wraps (unlike normal insulating tape). The tape can be used to insulate broken sections or electrical modifications. Of course, you can also use it to rewrap the entire wiring harness. Good protection against external mechanical abrasion (e.g. sharp edges) and dirt. Good temperature-resistant. Width: 19 mm. Length: 10 metres. Made in Germany. Ideal for Citroën 2CV, DS, ID, HY, 11CV, all classic Renault and Peugeot models.



Art.No.	Quality	needed qty
34627	2	1



Cable harness seal for the engine front wall. Material: Foam rubber. Diameter: about 45mm. Suitable for Citroën DS + Citroën 2CV, HY.



Art.No.	Quality	needed qty
10367	3	2



Citroën 2CV + DS
Cable harness seal for the engine front wall. Material: Foam rubber. Diameter: about 40mm. Suitable for Citroën DS + Citroën 2CV.



Art.No.	Quality	needed qty
34012	3	1



Cable harness for the windshield wiper engine (12 V). Suitable for Citroën HY. Made in Germany.



Art.No.	Quality	needed qty
48280	3	1



Headlight plug (with long connection cable + round plugs), for Bilux or H4 bulb. Suitable for Citroën DS, Citroën 2CV, Citroën HY. Made in Germany.



Art.No.	Quality	needed qty
34051	3	2



Citroën 2CV, Dyane, AML, HY
Connector suitable for main headlights, for Citroën 2CV, Dyane, Ami6+8, HY. The plug is supplied with short cable ends and round plugs.



Art.No.	Quality	needed qty
14402	3	2



3mm
round pin plug 3mm, male, like original.



Art.No.	Quality	needed qty
14487	3	1



0501 cable tree

1
2
3
4
5
6
7
8
9
10
11
12
13
14

3mm



Round pin plug, 3mm, feminine

Art.No.	Quality	needed qty
14488	3	



Citroën 3mm



Round plug 3mm. Stuffing contents: 10x plug, 10x sleeve. With suitable rubber sleeve and color markings! Optically like original! Made in Germany.

Art.No.	Quality	needed qty
14207	3	1



4mm



round pin plug 4mm, male, like original.

Art.No.	Quality	needed qty
14396	3	



4mm



Round pin plug, 4mm, feminine

Art.No.	Quality	needed qty
14397	3	



Citroën 4mm



Round plug 4mm. Stuffing contents: 10x plug, 10x sleeve. With suitable rubber sleeve and color markings! Optically like original! Made in Germany.

Art.No.	Quality	needed qty
14206	3	1



4mm



Cable harness color markings (100 item), for plugs with 4mm diameter. 9 different colors. Suitable for Citroën 2CV, DS, HY, SM, GS, CX, Peugeot

Art.No.	Quality	needed qty
35688	4	1



Fuse assortment.



Art.No.	Quality	needed qty
75321	3	1



10A



Glass fuse 10A, 6,3 x 32 mm

Art.No.	Quality	needed qty
14131	3	



15A



Glass fuse 15A. 6,3 x 32 mm

Art.No.	Quality	needed qty
14132	3	



30A



Glass fuse 30A, 6,3 x 32 mm

Art.No.	Quality	needed qty
14133	3	



Citroën



Fuse holder (cable shoe). High-quality reproduction of the original fixture, which never was available from Citroën. Made in Germany.

Art.No.	Quality	needed qty
14608	3	



6x3 x 32mm



Fuse set (glass fuse).Contents: 1x 5A, 10A , 15A, 20A, 30A (amps) each. Dimension: 6,3 x 32mm. Complete in an outer packaging (ideal for the 2CV, DS, HY... travel kit!).

Art.No.	Quality	needed qty
14139	3	1



Citroën 2CV, DS, HY



Fuse box lid (only the lid). For fuse box "SEIMA". Reproduction, but optically like original Citroën. Suitable for Citroën 2CV, DS, HY.

Art.No.	Quality	needed qty
14669	3	1



Citroën 2CV, DS, HY



Fuse box with lid. Color beige-grey. For 4 glass fuses. Inclusive the fixtures for the fuses. Reproduction, but optically like original Citroën. Suitable for Citroën 2CV, DS, HY.

Art.No.	Quality	needed qty
14668	3	1



Citroën 2CV, DS, HY



Fuse box with cap. Color grey. For 4 glass fuses. Original Citroën. Suitable for Citroën 2CV, DS, HY.

Art.No.	Quality	needed qty
14164	2	1



20A



Fuse box with cap. Color: black. Holds 4 glass fuses. Replica. Connection: flat plug! Compatible with Citroën 2CV, DS, and HY. Of course, this fuse box can also be used as a universal part!

Art.No.	Quality	needed qty
14187	4	1



20A





Fuse box with cap. Color: white. Holds 4 glass fuses. Replica. Connection: flat plug! Compatible with Citroën 2CV, DS, and HY. Of course, this fuse box can also be used as a universal part!

Art.No.	Quality	needed qty
14462	4	1





1,5 - 2,5mm² Cable Connector blue



Art.No.	Quality	needed qty
14472	3	1

Battery pole switch bent (space-saving). Just release knurled head bolt to stop current circuit. It can be very easily used when you do not use your car for long time (winter)! This switch replaces battery negative pole lead!

Art.No.	Quality	needed qty
14589	3	1

Battery pole switch. Just release knurled head bolt to stop current circuit. It can be very easily used when you do not use your car for long time (winter)! This switch replaces battery negative pole lead!



Art.No.	Quality	needed qty
14484	1	1

Coloured battery terminals. Red for positive. Black for negative. Suitable for all types. The risk of mixing up the terminals when connecting the battery is now minimised. These coloured battery terminal connectors are suitable for cables with a maximum diameter of 12 mm (cable cross-section up to 113 mm²). They fit terminal sizes of 16-19 mm. They are suitable for 6 V and 12 V batteries. And they look great too! Made in Germany

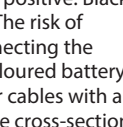

Art.No.	Quality	needed qty
14722	1	1

Battery pole negative -



Art.No.	Quality	needed qty
14119	3	1

Battery pole positive +



Art.No.	Quality	needed qty
14118	3	1

Battery pole plus + minus, with butterfly nut (colored in red + black). Universal suitable!



Art.No.	Quality	needed qty
85197	3	1

Stop light switch, suitable for Citroën 11CV/15CV, to year of construction 07/1952. Citroën HY, to year of construction 1963. Or. No. 712376



Art.No.	Quality	needed qty
60287	3	1

Crimping pliers for round plugs. Suitable for the uninsulated round plugs 3mm + 4mm. Brand quality KNIPEX



Art.No.	Quality	needed qty
21146	2	1

0,5 - 1,5mm² Flat plug red



Art.No.	Quality	needed qty
14470	3	1

Rubber cap for the connection to the starter motor. (Protecting cap). This cap should never be missing. Universal fitting! For max. cable diameters: 17,8mm. Inside diameter 22mm.

Art.No.	Quality	needed qty
14657	3	1

Rubber cap for the connection at the generator. (Protecting cap). This cap should never be missing. Universal fitting! For max. cable diameters: 7,62mm. Inside diameter 12,7mm.



Art.No.	Quality	needed qty
14262	3	1

19mm Isolation tape with fabric surface. This adhesive tape has been specially manufactured for cable harnesses. Vintage-style cotton fabric appearance, making it visually compatible with historical cable wraps (unlike normal insulating tape). The tape can be used to insulate broken sections or electrical modifications. Of course, you can also use it to rewrap the entire wiring harness. Good protection against external mechanical abrasion (e.g. sharp edges) and dirt. Good temperature-resistant. Width: 19 mm. Length: 10 metres. Made in Germany. Ideal for Citroën 2CV, DS, ID, HY, 11CV, all classic Renault and Peugeot models.





Art.No.	Quality	needed qty
34627	2	1

180 x Cable feed-through rubber kit. Contents: 40x6mm, 40x9mm, 40x10mm, 20x12mm, 25x11mm, 5x19,5mm, 5x21mm, 5x24mm.

Art.No.	Quality	needed qty
20238	4	1

Cable harness seal for the engine front wall. Material: Foam rubber. Diameter: about 45mm. Suitable for Citroën DS + Citroën 2CV, HY.

Art.No.	Quality	needed qty
10367	3	2

0502 cable tree accessories

1
2
3
4
5
6
7
8
9
10
11
12
13
14



Cable harness seal for the engine front wall. Material: Foam rubber. Diameter: about 40mm. Suitable for Citroën DS + Citroën 2CV.



Art.No.	Quality	needed qty
34012	3	1



Cable binder from rubber. Length: 12 x 160mm. Made in Germany. Now manufactured from improved material (NBR/SBR fabric rubber)



Art.No.	Quality	needed qty
36003	3	



Cable binder from rubber, length 155mm. Wide 35mm! For main cable harnesses to 30mm diameter. Now manufactured from improved material (NBR/SBR fabric rubber)



Art.No.	Quality	needed qty
36554	3	



Cable tie made of rubber, for 2CV/DS, like the original. Length: 270mm, breadth: 12mm. Made in Germany. Now manufactured from improved material (NBR/SBR fabric rubber)



Art.No.	Quality	needed qty
16156	3	2



Cable tie made of rubber, for 2CV/DS, like the original. Length: 320mm, breadth: 12mm. Made in Germany. Now manufactured from improved material (NBR/SBR fabric rubber)



Art.No.	Quality	needed qty
16583	3	2



cable strap, 122mm length. Made in Germany. Now manufactured from improved material (NBR/SBR fabric rubber)



Art.No.	Quality	needed qty
16152	3	



Cable binder from rubber. Length: 160mm. Made in Germany. Now manufactured from improved material (NBR/SBR fabric rubber)



Art.No.	Quality	needed qty
36002	3	



Cable binder from rubber. Length: 50mm. Made in Germany. Now manufactured from improved material (NBR/SBR fabric rubber)



Art.No.	Quality	needed qty
36004	3	



Cable binder from rubber. Length: 80mm. Made in Germany. Now manufactured from improved material (NBR/SBR fabric rubber)



Art.No.	Quality	needed qty
36005	3	



Cable binder made of metal. 1 range (10 pieces) consisting of: 2 x 75mm, 2 x 180mm, 6 x 100mm.



Art.No.	Quality	needed qty
60339	3	1



Cable tie assortment (black). 75 pieces. Content: 25 cable ties 3.0 x 100 mm, 25 cable ties 3.0 x 120 mm, 25 cable ties 3.6 x 200 mm



Art.No.	Quality	needed qty
20287	3	1



Cable grommet, 10x12x1,5mm



Art.No.	Quality	needed qty
20199	3	



Cable grommet, 12x20x4mm



Art.No.	Quality	needed qty
20200	3	



Cable grommet, 16x24x3mm



Art.No.	Quality	needed qty
20202	3	



Cable grommet, 21x31x1,5mm



Art.No.	Quality	needed qty
20203	3	



Cable grommet, 25x30x3,5mm



Art.No.	Quality	needed qty
20204	3	



Cable grommet, 4x7x1mm



Art.No.	Quality	needed qty
20195	3	

	Cable grommet, 6x8x1mm							
<table border="1"><tr><th>Art.No.</th><th>Quality</th><th>needed qty</th></tr><tr><td>20197</td><td>3</td><td></td></tr></table>	Art.No.	Quality	needed qty	20197	3			
Art.No.	Quality	needed qty						
20197	3							
	Cable grommet, 9x11x1mm							
<table border="1"><tr><th>Art.No.</th><th>Quality</th><th>needed qty</th></tr><tr><td>20198</td><td>3</td><td></td></tr></table>	Art.No.	Quality	needed qty	20198	3			
Art.No.	Quality	needed qty						
20198	3							
	Cable terminal strip, with 3 connection. Suitable for Citroën 11CV + 15CV. This terminal strip can be also universal used. Optimally to connect the positive cables cleanly. Or. No. 710161							
<table border="1"><tr><th>Art.No.</th><th>Quality</th><th>needed qty</th></tr><tr><td>60285</td><td>3</td><td>1</td></tr></table>	Art.No.	Quality	needed qty	60285	3	1		
Art.No.	Quality	needed qty						
60285	3	1						
	Cable terminal strip, with 5 connection. Suitable for Citroën 11CV + 15CV. This terminal strip can be also universal used. Optimally to connect the positive cables cleanly. Or. No. 710170							
<table border="1"><tr><th>Art.No.</th><th>Quality</th><th>needed qty</th></tr><tr><td>60286</td><td>3</td><td>1</td></tr></table>	Art.No.	Quality	needed qty	60286	3	1		
Art.No.	Quality	needed qty						
60286	3	1						
	Insulated cable plug, with 2 connectors (to combine connections). From 1 cable to 1 cable							
<table border="1"><tr><th>Art.No.</th><th>Quality</th><th>needed qty</th></tr><tr><td>20177</td><td>3</td><td></td></tr></table>	Art.No.	Quality	needed qty	20177	3			
Art.No.	Quality	needed qty						
20177	3							
	Insulated cable plug, from 1 cable to 1 cable							
<table border="1"><tr><th>Art.No.</th><th>Quality</th><th>needed qty</th></tr><tr><td>20178</td><td>3</td><td></td></tr></table>	Art.No.	Quality	needed qty	20178	3			
Art.No.	Quality	needed qty						
20178	3							
	Cable connectors, isolated from 1 cable to 2 cables							
<table border="1"><tr><th>Art.No.</th><th>Quality</th><th>needed qty</th></tr><tr><td>20176</td><td>3</td><td></td></tr></table>	Art.No.	Quality	needed qty	20176	3			
Art.No.	Quality	needed qty						
20176	3							
	Popular assortment of rubber Wiring & Blanking grommets. Wiring Grommets from 6mm to 16mm. Blanking Grommets from 8mm to 25mm. Box Qty 240							
<table border="1"><tr><th>Art.No.</th><th>Quality</th><th>needed qty</th></tr><tr><td>60295</td><td>3</td><td>1</td></tr></table>	Art.No.	Quality	needed qty	60295	3	1		
Art.No.	Quality	needed qty						
60295	3	1						

	Ground cable 500mm long, universal							
<table border="1"><tr><th>Art.No.</th><th>Quality</th><th>needed qty</th></tr><tr><td>14460</td><td>3</td><td>1</td></tr></table>	Art.No.	Quality	needed qty	14460	3	1		
Art.No.	Quality	needed qty						
14460	3	1						
	Eye ring blue, 10mm attaching lug. Blue = cable diameter: 2,3 to 5,0mm.							
<table border="1"><tr><th>Art.No.</th><th>Quality</th><th>needed qty</th></tr><tr><td>14576</td><td>3</td><td>1</td></tr></table>	Art.No.	Quality	needed qty	14576	3	1		
Art.No.	Quality	needed qty						
14576	3	1						
	Eye ring blue, 6mm attaching lug. Blue = cable diameter: 2,3 to 5,0mm.							
<table border="1"><tr><th>Art.No.</th><th>Quality</th><th>needed qty</th></tr><tr><td>14574</td><td>3</td><td>1</td></tr></table>	Art.No.	Quality	needed qty	14574	3	1		
Art.No.	Quality	needed qty						
14574	3	1						
	Eye ring blue, 8mm attaching lug. Blue = cable diameter: 2,3 to 5,0mm.							
<table border="1"><tr><th>Art.No.</th><th>Quality</th><th>needed qty</th></tr><tr><td>14575</td><td>3</td><td>1</td></tr></table>	Art.No.	Quality	needed qty	14575	3	1		
Art.No.	Quality	needed qty						
14575	3	1						
	Eye ring red, 10mm attaching lug							
<table border="1"><tr><th>Art.No.</th><th>Quality</th><th>needed qty</th></tr><tr><td>14573</td><td>3</td><td>1</td></tr></table>	Art.No.	Quality	needed qty	14573	3	1		
Art.No.	Quality	needed qty						
14573	3	1						
	0,5 - 1,5mm ² Eye ring red, 5mm							
<table border="1"><tr><th>Art.No.</th><th>Quality</th><th>needed qty</th></tr><tr><td>14471</td><td>3</td><td></td></tr></table>	Art.No.	Quality	needed qty	14471	3			
Art.No.	Quality	needed qty						
14471	3							
	Eye ring red, 6mm attaching lug							
<table border="1"><tr><th>Art.No.</th><th>Quality</th><th>needed qty</th></tr><tr><td>14571</td><td>3</td><td>1</td></tr></table>	Art.No.	Quality	needed qty	14571	3	1		
Art.No.	Quality	needed qty						
14571	3	1						
	Eye ring red, 8mm attaching lug							
<table border="1"><tr><th>Art.No.</th><th>Quality</th><th>needed qty</th></tr><tr><td>14572</td><td>3</td><td>1</td></tr></table>	Art.No.	Quality	needed qty	14572	3	1		
Art.No.	Quality	needed qty						
14572	3	1						
	3mm round pin plug 3mm, male, like original.							
<table border="1"><tr><th>Art.No.</th><th>Quality</th><th>needed qty</th></tr><tr><td>14487</td><td>3</td><td></td></tr></table>	Art.No.	Quality	needed qty	14487	3			
Art.No.	Quality	needed qty						
14487	3							

- 1
- 2
- 3
- 4
- 5
- 6
- 7
- 8
- 9
- 10
- 11
- 12
- 13
- 14

0502 cable tree accessories

1
2
3
4
5
6
7
8
9
10
11
12
13
14

3mm



Round pin plug, 3mm, feminine



Art.No.	Quality	needed qty
14488	3	

Citroën 3mm



Round plug 3mm. Stuffing contents: 10x plug, 10x sleeve. With suitable rubber sleeve and color markings! Optically like original! Made in Germany.



Art.No.	Quality	needed qty
14207	3	1

4mm



round pin plug 4mm, male, like original.



Art.No.	Quality	needed qty
14396	3	

4mm



Round pin plug, 4mm, feminine



Art.No.	Quality	needed qty
14397	3	

Citroën 4mm



Round plug 4mm. Stuffing contents: 10x plug, 10x sleeve. With suitable rubber sleeve and color markings! Optically like original! Made in Germany.



Art.No.	Quality	needed qty
14206	3	1

4mm



Cable harness color markings (100 item), for plugs with 4mm diameter. 9 different colors. Suitable for Citroën 2CV, DS, HY, SM, GS, CX, Peugeot



Art.No.	Quality	needed qty
35688	4	1

0,5 - 1,5mm²



Round plug male, red



Art.No.	Quality	needed qty
14469	3	

0,5 - 1,5mm²



Round plug fememin, red



Art.No.	Quality	needed qty
14468	3	



Universal protective rubber (e.g. for protecting electric cables, brake lines, brake hoses, handbrake cables, speedometer cables, petrol hose... External dimensions: 23x30mm. Inner diameter: 8mm. The rubber is slit on one long side, and can therefore be easily placed over the cable to be protected!



Art.No.	Quality	needed qty
83441	3	

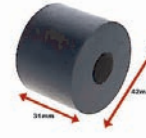

Universal protective rubber (e.g. for protecting electric cables, handbrake cables, petrol hose... External dimension: 42mm. Length: 31mm. Inner diameter: 12mm. The rubber is not slit (but of course this can be done afterwards if it makes assembly easier)



Art.No.	Quality	needed qty
83442	3	



Heat shrink tubing (kit from 100). These handy sheaths form a protective water resistant insulation over exposed wiring and electrical connections. Designed for automotive use. Supplied in a plastic organiser.



Art.No.	Quality	needed qty
21045	1	1

10A



Glass fuse 10A, 6,3 x 32 mm



Art.No.	Quality	needed qty
14131	3	

15A



Glass fuse 15A, 6,3 x 32 mm



Art.No.	Quality	needed qty
14132	3	

30A



Glass fuse 30A, 6,3 x 32 mm



Art.No.	Quality	needed qty
14133	3	

Citroën



Fuse holder (cable shoe). High-quality reproduction of the original fixture, which never was available from Citroën. Made in Germany.



Art.No.	Quality	needed qty
14608	3	



Fuse set (glass fuse). Contents: 1x 5A, 10A, 15A, 20A, 30A (amps) each. Dimension: 6,3 x 32mm. Complete in an outer packaging (ideal for the 2CV, DS, HY... travel kit!).



Art.No.	Quality	needed qty
14139	3	1

Citroën 2CV, DS, HY



Fuse box lid (only the lid). For fuse box "SEIMA". Reproduction, but optically like original Citroën. Suitable for Citroën 2CV, DS, HY.



Art.No.	Quality	needed qty
14669	3	1

Citroën 2CV, DS, HY



Fuse box with lid. Color beige-grey. For 4 glass fuses. Inclusive the fixtures for the fuses. Reproduction, but optically like original Citroën. Suitable for Citroën 2CV, DS, HY.



Art.No.	Quality	needed qty
14668	3	1

Citroën 2CV, DS, HY



Fuse box with cap. Color grey. For 4 glass fuses. Original Citroën. Suitable for Citroën 2CV, DS, HY.



Art.No.	Quality	needed qty
14164	2	1



Fuse box with cap. Color: black. Holds 4 glass fuses. Replica. Connection: flat plug! Compatible with Citroën 2CV, DS, and HY. Of course, this fuse box can also be used as a universal part!



Art.No.	Quality	needed qty
14187	4	1



Fuse box with cap. Color: white. Holds 4 glass fuses. Replica. Connection: flat plug! Compatible with Citroën 2CV, DS, and HY. Of course, this fuse box can also be used as a universal part!



Art.No.	Quality	needed qty
14462	4	1

www.franzose.com



0503 illuminant (light bulbs) 6+12 volt

1
2
3
4
5
6
7
8
9
10
11
12
13
14



Light bulb 12V, 2 Watt for pilot lamp (articles 50056-50059), socket BA7's



Art.No.	Quality	needed qty
50096	3	2

12 Volt / 21 W



Bulb 21Watt, front indicator, rear brake light, 12 Volt, Ba15s



Art.No.	Quality	needed qty
14035	3	1

12 V / 21W



Bulb 21 watt, Ba15s, 12 Volt yellow dyes for white turn signal glasses



Art.No.	Quality	needed qty
14036	3	1

12 V / 35W



Bulb 35watt, Ba15s, 12 Volt yellow dyes for white turn signal glasses



Art.No.	Quality	needed qty
14686	3	2

12 Volt / 35/35 Watt



Bulb 12 V, 35/35 Watt, clearly. Base Ba20d.



Art.No.	Quality	needed qty
14415	3	2

remaining stock! While stocks last!

12 Volt / 4 W



Bulb 12 Volt, 4 Watt. Base Ba9s. E.G. parking light Citroën 2CV, instrument lights Peugeot 504. Peugeot Or. No. 6372.12



Art.No.	Quality	needed qty
14034	3	2

12 Volt / 40/45 Watt



Bulb 12 V, 40/45 Watt, yellow, bases with 3 pins, Ba21d



Art.No.	Quality	needed qty
14407	3	2



Bulb 12 V, 40/45 Watt, clearly, bases with 3 pins, Ba21d



Art.No.	Quality	needed qty
14408	3	2

12 Volt / 45 Watt



Bulb 12 V, 45 Watts, clearly, bases with 3 pins, Ba21s.



Art.No.	Quality	needed qty
14413	3	2



Bulb 12 V, 45/40 Watt, clearly. Base Ba20d.



Art.No.	Quality	needed qty
14417	3	2



Bulb 12 V, 5 Watts, low version for interior light Citroën 2CV etc., base BA15s.



Art.No.	Quality	needed qty
14364	3	1

12 Volt / 5/21 W



Bulb 5/21 watt, 12 Volt, for AK400 rear light, DS Break, HY, Bay 15d



Art.No.	Quality	needed qty
14037	3	1

12 Volt / 45/40 W



Double filament bulb 45/40W, 12V.



Art.No.	Quality	needed qty
14031	3	2



Bulb 12 V, H1, 55 W, in clear!!! E.G. Citroën DS, Peugeot 504 Cabrio.



Art.No.	Quality	needed qty
14378	2	2



Bulb H3, 12 volt, 55 W. For example for Citroën DS.



Art.No.	Quality	needed qty
14376	2	2



H4 bulb with two-filament base, 12V,



Art.No.	Quality	needed qty
14032	1	2



Bulb 12 V, H4, 35/35 Watt! Light switches, which are not circuit over a relay, work longer.



Art.No.	Quality	needed qty
14359	3	2



Light bulb 12 Volt, H4, 55/60 Watt, in yellow!!! Not permitted within the jurisdiction of the german Road Traffic Regulations. Consisting of 1x H4 bulb + glass bulb in yellow (which is put over the H4 bulb).



Art.No.	Quality	needed qty
14049	3	2

illuminant (light bulbs) 6+12 volt 0503

	H4 bulb, 60/55W, 12V	
Art.No. 14030	Quality 3	needed qty 2
	H4 all-weather bulb, shines slightly yellow, accepted by German TÜV, 12V, 60/55W	
Art.No. 14033	Quality 3	needed qty 2
	Bulb 12 V, H4, 55/60 Watt. Manufacturer: PHILIPS. Test winner in many comparison tests for classic car headlamps. Best illuminating, best brightness.	
Art.No. 14648	Quality 1	needed qty 2
	Bulb 12 V. 2 Watt, base Ba 9s. (Instrument lights 2CV, ID19, HY, Peugeot 504). Peugeot Or. No. 6371.20	
Art.No. 14070	Quality 3	needed qty 1
	Two-filament bulb 40/45 W, 12 Volt, yellow ! Not allowed in German traffic	
Art.No. 14048	Quality 3	needed qty 2
	H4 Bulb 12 V. H4, glass yellow for H4 lamp. The glass is inverted over the H4 lamp. The glass can be dismantled at any time again.	
Art.No. 14389	Quality 3	needed qty 2
	Bulb 6 V, 1,2 Watt. Base Ba7S. For the large control light by older 2CV + HY. Fits naturally also with other French car.	
Art.No. 14282	Quality 3	needed qty 2
	Bulb 6 V, 15 Watt. Base Ba 15s for original lateral indicators above, Citroën 2CV from the fifties.	
Art.No. 14177	Quality 3	needed qty 2
	Bulb 18 Watt, 6 volt	
Art.No. 14045	Quality 3	needed qty 2

	ball bulb 2 Watt 6 Volt, base Ba9s / side flasher-parking lights	
Art.No. 14267	Quality 3	needed qty 2
	Bulb 21 Watt, 6 Volt	
Art.No. 14044	Quality 3	needed qty 2
	Bulb, 6 Volt, 21/5 Watt, Bay 15d socket.	
Art.No. 14079	Quality 3	needed qty 2
	ball bulb 3 Watt 6 Volt base Ba15s	
Art.No. 14269	Quality 3	needed qty 2
	ball bulb 4 Watt 6 Bolt base Ba9s / side flasher-parking lights	
Art.No. 14268	Quality 3	needed qty 2
	Bulb 6 Volt, 5 Watt. Coloured red. Ba15s base. Especially for rear lights if the cap is slightly faded!	
Art.No. 14274	Quality 3	needed qty 2
	ball bulb 5 Watt 6 Volt base Ba15s / rear light, license plate light	
Art.No. 14270	Quality 3	needed qty 2
	ball bulb 5/18 Watt 6 Volt base Bay15d / rear and brake light	
Art.No. 14266	Quality 3	needed qty 2
	Bulb 6V, double-filament bulb, base P45T, 40/45 Watt, in dark yellow!!	
Art.No. 14180	Quality 3	needed qty 2

- 1
- 2
- 3
- 4
- 5
- 6
- 7
- 8
- 9
- 10
- 11
- 12
- 13

0503 illuminant (light bulbs) 6+12 volt

1
2
3
4
5
6
7
8
9
10
11
12
13
14



Two-filament bulb 40/45watt, 6 volt!



Art.No.	Quality	needed qty
14043	3	2



Bulb 6V, H4 with Bilux base (P45T), 55/60 Watt



Art.No.	Quality	needed qty
14461	1	2



Ball lamp 6volt, 10watt. BA15S



Art.No.	Quality	needed qty
14388	3	2



Bulb 6Volt, 3 Watt, base W2.1x9,5d. (Control light)



Art.No.	Quality	needed qty
85340	3	2



P45 > H4

Bulb adapter rings (2 pieces), from double filament bulb to H4. With this, every headlight that originally has a double filament bulb (P45) can be converted to an H4 bulb. You get much better light! Universal suitable.



Art.No.	Quality	needed qty
14687	3	1



H4 > LED

Bulb conversion kit, from H4 (base P43t) to LED light! This kit replaces the H4 bulb with an LED bulb. Significantly brighter light. But beware: This is not authorised in Germany! The kit consists of 2x H4 LED bulbs. You don't have to convert anything, just replace them! For the experts: Colour temperature (K): 6000. Lumen: 2400. 12 Volt.



Art.No.	Quality	needed qty
14689	1	1



Box of spare bulbs two-filament, 12 Volt, should always be in your car!



Art.No.	Quality	needed qty
14041	3	2



Box of spare bulbs H4, 12 Volt



Art.No.	Quality	needed qty
14042	3	2

Ba9s



Bulbs support (9,8mm diameter) for speedometer lights, base Ba9s. The lamp holder can be used also as parking light. For 2CV you require then a rubber with the dimensions: 10x12x1,5mm.



Art.No.	Quality	needed qty
14071	3	1



Citroën
Renault
Peugeot

Bulb base (plug) for headlamp. Double-filament bulb + H4. Suitable for Citroën 2CV, HY, DS, Renault R4, Peugeot 403, 404, etc.



Art.No.	Quality	needed qty
14072	4	2

Ba15s



lamp base Ba15s, 6 + 12 Volt, single-pole



Art.No.	Quality	needed qty
14275	3	2

lamp base Ba7s, 6 + 12 Volt, single-pole



Art.No.	Quality	needed qty
14272	3	2



Citroën
2CV, Dyane, AMI, HY

Connector suitable for main headlights, for Citroën 2CV, Dyane, Ami6+8, HY. The plug is supplied with short cable ends and round plugs.



Art.No.	Quality	needed qty
14402	3	2



Fuse assortment.



Art.No.	Quality	needed qty
75321	3	1

12 Volt / 10 Watt



Festoon bulb 10W, 12 Volt. 11x43mm. Base SV8.5



Art.No.	Quality	needed qty
14039	3	2

12 Volt / 18 Watt



Festoon bulb 18W, 12 Volt. 2CV for side indicator C-pillar. 15x43mm. Base SV8.5



Art.No.	Quality	needed qty
14040	3	2

12Volt / 5 Watt



Sofitte 12 V, 5 Watts. 11x38mm, base SV8,5. e.g. back lights Peugeot 203 Pik Up.....



Art.No.	Quality	needed qty
14428	3	2

illuminant (light bulbs) 6+12 volt 0503

12 Volt / 5 Watt



Festoon bulb 5W, 12 Volt.
11x43mm. Base SV8.5



Art.No.	Quality	needed qty
14038	3	

6 Volt / 18 Watt



Festoon bulb 6 volt 18 W.
15x44mm. Base SV8.5



Art.No.	Quality	needed qty
14046	3	



Renault

Sofitte 6 V, 10 Watts. 11x38mm,
base SV8,5. e.g. back lights
Citroën 11CV.



Art.No.	Quality	needed qty
14427	3	

6 Volt / 5 Watt



Sofitte 6 V, 5 Watts. 11x38mm,
base SV8,5.



Art.No.	Quality	needed qty
14426	3	

6 Volt / 10 Watt



Festoon bulb, 6 volt, 10W,
measure: 11x43mm, SV8,5



Art.No.	Quality	needed qty
14047	3	

6 Volt / 5 Watt



Festoon bulb 6 Volt, 5 Watt.
11x43mm. Base SV8.5



Art.No.	Quality	needed qty
14075	3	



FRENCH AUTOMOBILE CULTURE



www.cipere.fr

www.franzose.de

www.franzose.com

0504 electric + dashboard

1
2
3
4
5
6
7
8
9
10
11
12
13
14



12 Volt
12-volt cigarette lighter. Universally compatible. Installation opening: 27.5 mm. Good quality. Also ideal as a car socket for 12-volt devices.



Art.No.	Quality	needed qty
14641	3	1



Citroen
Blindcap for angular switches in the dashboard. Suitable for Citroën 2CV + HY.



Art.No.	Quality	needed qty
14617	3	1



Citroën 2CV + HY
Brake fluid - control switch, for 2CV + HY. Original Installed in the dashboard. Final version.



Art.No.	Quality	needed qty
14281	3	1



Citroen 2CV + HY
Fog tail light switch angularly, suitable for Citroën 2CV + HY. Original Installed in the dashboard. Final version.



Art.No.	Quality	needed qty
14616	3	1



Citroën 2CV + HY
windscreen wiper switch angular, Citroën 2CV + HY. Mounted in the dashboard. Installed up to production end.



Art.No.	Quality	needed qty
14279	3	1



Warning light switch angularly, for 2CV + HY. Original Installed in the dashboard. Final version!



Art.No.	Quality	needed qty
14280	3	1



Citroen DS + HY
Sticker for pressure switches (square switches) in dashboard. Set of 3 (interior lighting, fan, heated rear window). Suitable for Citroën DS + HY



Art.No.	Quality	needed qty
35663	3	1



Citroën
Aufkleber für Druckschalter Parkleuchte, links oder rechts (eckige Schalter) im Armaturenbrett. Passend für Citroën DS, bis Baujahr 07/1972. Für Schalter DX522-8



Art.No.	Quality	needed qty
35983	3	1



Citroën
Sticker for pressure switch warning light (square switch) in the dashboard. Suitable for Citroën DS, HY, AMI, 2CV, GS



Art.No.	Quality	needed qty
35970	3	1



12 Volt
Indicator - buzzer. 12 V. Fits universal. So you never forget to turn off the switch from the indicator. Simple assembly: Connection: Parallel from the connection of the flasher relay (for flash control light) to the control light connection.



Art.No.	Quality	needed qty
14632	1	1



Citroen 2CV + HY
Turn signal lever solo, in brown(marron). Suitable for Citroën 2CV + Citroën HY. With the lever a broken indicator switch can be repaired.



Art.No.	Quality	needed qty
14596	3	1



Citroen 2CV + HY
Turn signal lever solo, in grey. Suitable for Citroën 2CV + Citroën HY. With the lever a broken indicator switch can be repaired.



Art.No.	Quality	needed qty
14595	3	1



Citroen 2CV + HY
Turn signal lever solo, in black. Suitable for Citroën 2CV + Citroën HY. With the lever a broken indicator switch can be repaired.



Art.No.	Quality	needed qty
14193	2	1



Citroen 2CV + HY
Indicator lever from synthetic, chrome-plated, for Citroën 2CV. With the lever a broken indicator switch can be repaired.



Art.No.	Quality	needed qty
14367	3	1



Citroen 2CV + HY
Turn signal switch at the steering column, color brown (Marron). Reproduction. Suitable for Citroën 2CV to year of construction 1990. Citroën HY



Art.No.	Quality	needed qty
14182	3	1



Citroen 2CV + HY
Turn signal switch at the steering column, color black. Reproduction. Suitable for Citroën 2CV to year of construction 1990. Citroën HY



Art.No.	Quality	needed qty
14181	3	1



Citroen 2CV + HY
Turn signal switch at steering column, color grey-white. Original Citroën. Suitable for Citroën 2CV. Citroën HY





Art.No.	Quality	needed qty
14122	3	1



Citroën 2CV + HY

Turn signal switch sheet metal holder for 2CV + HY



Art.No.	Quality	needed qty
14482	3	1

6 Volt 5x1821W

6-volt electronic flasher relay. Power output from 10 watts to 110 watts! Branded product. This flasher relay is universally applicable for classic cars with 6-volt on-board voltage (Citroën 2CV, DS, HY, Renault R4, Renault with rear engines). It can also be used for operation with a trailer coupling!



Art.No.	Quality	needed qty
14366	1	1

12 Volt

Indicator-flash relay round, electromechanical. 12 volts, max. 4x21 watt. 3 poles X/P/L !!! This flasher relay is electromechanical, not electronic! This makes it insensitive to voltage fluctuations and it still makes real click-click noises (like in the past). Suitable for Citroën 2CV, Dyane, Mehari, AMI, DS, HY, Peugeot + Renault. Power supply symbol (+, X or B). Connection turn signal front + rear = symbol (C or L). Connection indicator light dashboard = symbol (R or P). This flasher relay is made exclusively for us! Attention: Pay attention to the pin assignment of the relay. Do not simply change the plugs! The plug designation is also printed again on the housing!



Art.No.	Quality	needed qty
14361	3	1

12 Volt

Flasher relay, 12 V, 3 plug connections. 180 Watt power output. Suitable for Citroën 2CV, DS, HY, Renault R4, Peugeot 203, 403, 404 etc. The flasher relay does not make "click-click" noises. Connection French: Current supply symbol (+). Connection indicator in front + rear = symbol (C). Connection control light dashboard = symbol (R). If a Japanese relay is used: Plus + = symbol X or B. Connection indicator C = symbol L. connection control of R = symbol P.



Art.No.	Quality	needed qty
14112	3	1

Citroën HY

Threaded knob for the ventilation flap. Suitable for Citroën HY. High-quality reproduction.

Art.No.	Quality	needed qty
44933	3	2



Push button switch universal, with white push-button (e.g. engine activate button). 16mm installation hole.

Art.No.	Quality	needed qty
85202	3	1





Push button, starter button in red. As an alternative to the original thin starter buttons. Unfortunately, the original starter buttons are no longer available. Dimensions: Total diameter: 3cm. Overall height: 9cm.

Art.No.	Quality	needed qty
50060	3	1



Push button for starting knob. 22mm hole.

Art.No.	Quality	needed qty
50062	3	



Light bulb 12V, 2 Watt for pilot lamp (articles 50056-50059), socket BA7's

Art.No.	Quality	needed qty
50096	3	

Bulb 12 V. 2 Watt, base Ba 9s. (Instrument lights 2CV, ID19, HY, Peugeot 504). Peugeot Or. No. 6371.20



Art.No.	Quality	needed qty
14070	3	1

Ba9s

Bulbs support (9,8mm diameter) for speedometer lights, base Ba9s. The lamp holder can be used also as parking light. For 2CV you require then a rubber with the dimensions: 10x12x1,5mm.



Art.No.	Quality	needed qty
14071	3	1

Citroën DS > 1968 Citroën HY



Rubber knob for the heater flow control valve, in the interior (engine tunnel). Suitable for Citroën DS Non Pallas, up to year of construction 1968. Citroën HY for the heating. Or. No. ZC9804104U

Art.No.	Quality	needed qty
32262	3	1

Fixture for angular switches (for mounting under the dashboard). Suitable for switch with 36x18mm installation hole.

Art.No.	Quality	needed qty
75148	3	

Heater adjustment lever with fixture. Suitable for Citroën 2CV, HY, Mehari. Reproduction out of painted sheet metal. Or. No. 5403748

Art.No.	Quality	needed qty
14529	3	1



0504 electric + dashboard

1
2
3
4
5
6
7
8
9
10
11
12
13
14



Heater adjustment lever with fixture. Suitable for Citroën 2CV, HY, Mehari. Chrome-plated. Or. No. 5403748



Art.No.	Quality	needed qty
14515	3	1



Instrument fixture (made of metal) for 1 additional instrument with 52mm diameter. Universal fitting. Made in Germany.



Art.No.	Quality	needed qty
60108	3	1



Instrument fixture (made of metal) for 2 additional instruments with 52mm diameter. Universal fitting. Made in Germany.



Art.No.	Quality	needed qty
60107	3	1

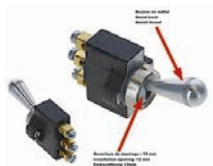

Toggle switch with polished head. Version: Changeover switch. 3x electrical connection. Load capacity: 5 amps. Bore diameter: 12.5mm. This switch is a changeover switch. You can therefore switch 2 functions. But of course it can also be used as a normal toggle switch. Then only 2 electrical connections are connected.



Art.No.	Quality	needed qty
50061	3	1



Knob for opening mechanism of the Ventilation shutter. Color blue, production from hard plastic. Suitable for Citroën 2CV, HY, 11CV. At the 2CV the knob was also installed for the headlight vertical adjustment.



Art.No.	Quality	needed qty
16468	4	1



Knob for opening mechanism of the Ventilation shutter. Color cream, production from hard plastic. Suitable for Citroën 2CV, HY, 11CV. At the 2CV the knob was also installed for the headlight vertical adjustment.



Art.No.	Quality	needed qty
16470	4	1



Knob for opening mechanism of the Ventilation shutter. Color grey, production from hard plastic. Suitable for Citroën 2CV, HY, 11CV. At the 2CV + AMI6 the knob was also installed for the headlight vertical adjustment.



Art.No.	Quality	needed qty
16284	4	1



Knob for opening mechanism of the Ventilation shutter. Color white, production from hard plastic. Suitable for Citroën 2CV, HY, 11CV. At the 2CV the knob was also installed for the headlight vertical adjustment.



Art.No.	Quality	needed qty
16466	4	1



Knob for opening mechanism of the Ventilation shutter. Color green, production from hard plastic. Suitable for Citroën 2CV, HY, 11CV. At the 2CV the knob was also installed for the headlight vertical adjustment.



Art.No.	Quality	needed qty
16471	4	1



Knob for opening mechanism of the Ventilation shutter. Color orange, production from hard plastic. Suitable for Citroën 2CV, HY, 11CV. At the 2CV the knob was also installed for the headlight vertical adjustment.



Art.No.	Quality	needed qty
16469	4	1



Knob for opening mechanism of the Ventilation shutter. Color red, production from hard plastic. Suitable for Citroën 2CV, HY, 11CV. At the 2CV the knob was also installed for the headlight vertical adjustment.



Art.No.	Quality	needed qty
16467	4	1



Knob for opening mechanism of the Ventilation shutter. Color black, production from hard plastic. Suitable for Citroën 2CV, HY, 11CV. At the 2CV + AMI6 the knob was also installed for the headlight vertical adjustment.



Art.No.	Quality	needed qty
16173	4	1



Knob round, colour grey, screwable, for heating adjustment and air distribution, bench lock. Reproduction made of metal! Suitable for Citroën 2CV, DS, HY.



Art.No.	Quality	needed qty
14526	3	1



Knob round, colour black, screwable, for heating adjustment and air distribution. Reproduction made of metal! Suitable for Citroën 2CV, DS, HY.



Art.No.	Quality	needed qty
14527	3	1



Knob round, chrome plated, screwable, for heating adjustment and air distribution. Reproduction made of metal! Suitable for Citroën 2CV, DS, HY.



Art.No.	Quality	needed qty
14528	1	



Control light blue, version Jaeger. This very good reproduction of the Jaeger light are installed partly in 2CV AZAM + AMI6, 2CV (from Belgian production). Citroën HY. Installation hole: 10mm.



Art.No.	Quality	needed qty
14600	3	1



Control lamp red for Citroën 2CV, HY, DS, with chrome border, reproduction of the original. The suitable bulb has our number 14070.



Art.No.	Quality	needed qty
14294	3	2



Control light Citroën 2CV, HY, DS. Like original, color black with 4 differently colored caps (green, blue, red, orange)



Art.No.	Quality	needed qty
14615	3	3



Control light Citroën 2CV, HY, DS. Like original, color: chromium-plated, with 4 differently colored metal caps (green, blue, red, orange)



Art.No.	Quality	needed qty
14631	3	3



Control light green, version "Jaeger". This very good reproduction of the Jaeger light is installed partly in 2CV AZAM + AMI6, 2CV (from Belgian production). Citroën HY. Installation hole: 10mm.



Art.No.	Quality	needed qty
14599	3	1



Control light green, largely, conically. Reproduction of the original lights. Unfortunately the quality is not so good. Suitable for Citroën 2CV, DS, HY.



Art.No.	Quality	needed qty
14191	5	1



Warning light with polished aluminium lid, blue



Art.No.	Quality	needed qty
50058	3	



Warning light with polished aluminium lid, yellow-orange



Art.No.	Quality	needed qty
50059	3	



Warning light with polished aluminium lid, green



Art.No.	Quality	needed qty
50057	3	



Warning light with polished aluminium lid, red



Art.No.	Quality	needed qty
50056	3	



Control light orange, version "Jaeger". This very good reproduction of the Jaeger light is installed partly in 2CV AZAM + AMI6, 2CV (from Belgian production). Citroën HY. Installation hole: 10mm.



Art.No.	Quality	needed qty
14598	3	1



Control light red, version "Jaeger". This very good reproduction of the Jaeger light is installed partly in 2CV AZAM + AMI6, 2CV (from Belgian production). Citroën HY. Installation hole: 10mm.



Art.No.	Quality	needed qty
14597	3	1



Red indicator light, large, cone-shaped (LED), 12 Volt. Reproduction of the original lights. So visually "nostalgic" but with modern technology! Suitable for Citroën 2CV (old models), AZU, HY, DS. Diameter for installation: 17.0 mm



Art.No.	Quality	needed qty
14697	3	1



Red indicator light, large, cone-shaped (LED), 6 Volt. Reproduction of the original lights. So visually "nostalgic" but with modern technology! Suitable for Citroën 2CV (old models), AZU, HY, DS. Diameter for installation: 17.0 mm



Art.No.	Quality	needed qty
14698	3	1



Control light red, largely, conically. Reproduction of the original lights. Unfortunately the quality is not so good. Suitable for Citroën 2CV, DS, HY.



Art.No.	Quality	needed qty
14192	5	1

0504 electric + dashboard

1
2
3
4
5
6
7
8
9
10
11
12
13
14



Light + horn switch in grey for Citroën 2CV (1961 > 1970), 11CV, HY. Reproduction. The switch has only 1 horn function (no town and country horn).



Art.No.	Quality	needed qty
14222	4	1



Light + horn switch in black 2CV, reproduction, looks like the 50's version, fits also for HY, 11cv. The switch has only 1 horn function (no town and cross-country horn).



Art.No.	Quality	needed qty
14228	3	1



Light - buzzer. 12 V. Universal fitting. Simple installation.



Art.No.	Quality	needed qty
14176	1	1



Headlight flasher switch universal. The operating lever is about 105mm long. It switches in all directions!



Art.No.	Quality	needed qty
85191	1	1



Light + horn switch, replica, on the steering column 2CV, HY. Colour black. Installed up to year of manufacture 1990, optically like original!



Art.No.	Quality	needed qty
14483	3	1



Nut for the handwheel of the headlight adjustment and the Ventilation shutter. Suitable for Citroën 2CV. Heater adjustment for Citroën HY + DS19



Art.No.	Quality	needed qty
16602	2	2



Switch - push button, square, with chrome frame. Universally suitable. Please note: this is a push button and not a toggle switch. The push button is useful for electric windscreen washers, horns or headlight flashers, for example. Dimensions: 36x18mm (French standard size). Suitable for Peugeot, Citroën, Renault.



Art.No.	Quality	needed qty
85448	3	1



Square switch with chrome frame. The switch also has an indicator light (bulb base Ba9s). Universal switch for e.g. heater blowers, additional consumers.... Dimensions: 36x18mm (French standard size). Suitable for Peugeot, Citroën, Renault.



Art.No.	Quality	needed qty
75149	3	1



Speedometer screen (120km/H), with printing (for the oval Veglia speedometer, 12 Volt). Suitable for Citroën 2CV + HY.



Art.No.	Quality	needed qty
17540	4	1



Speedometer screen (120km/H), with printing (for the oval Veglia speedometer, 12 Volt). Suitable for Citroën 2CV, AMI6, HY.



Art.No.	Quality	needed qty
17542	4	1



Speedometer screen (130km/H), with printing (for the oval Veglia speedometer, 6 Volt). Suitable for Citroën 2CV, AMI6, HY.



Art.No.	Quality	needed qty
17544	4	1



Speedometer screen (130km/H), with printing (for the oval Jaeger speedometer, 12 Volt). Suitable for Citroën 2CV + HY.



Art.No.	Quality	needed qty
17539	4	1



Speedometer screen (130km/H), with printing (for the oval Jaeger speedometer, 12 Volt). Suitable for Citroën 2CV, AMI6, HY.



Art.No.	Quality	needed qty
17543	4	1



Speedometer screen (140km/H), with printing (for the oval Veglia speedometer, 12 Volt). Suitable for Citroën 2CV, AMI6, HY.



Art.No.	Quality	needed qty
17541	4	1



Speedometer scale, for the oval speedometer. In the style of the seventies. Pictured on yellow background. Suitable for Citroën 2CV4 + 2CV6, HY.



Art.No.	Quality	needed qty
17522	3	1



USB A+C adapter (12 volt) for cigarette lighter. The adapter has 2 connections. 1x USB-A (the large wide plug) and 1x UBB-C (the new small plugs).



Art.No.	Quality	needed qty
14658	3	1



Hazard warning lights switch 12 Volt! Manufacturer Bosch! The hazard flasher system uses the existing flasher relay and is relatively easy to install. Attention: a suitable bulb must be ordered separately. Our article number 14425.



Art.No.	Quality	needed qty
14659	2	1



6 Volt
Hazard warning lights switch 6 Volt! Manufacturer Bosch! The hazard flasher system uses the existing flasher relay and is relatively easy to install. Attention: a suitable bulb must be ordered separately. Our article number 14282.



Art.No.	Quality	needed qty
14218	2	1



12 Volt
Hazard warning signal switch, universal, 12volt, Manufacturer HELLA The switcher uses the actual indicator-relais. easy to fit.



Art.No.	Quality	needed qty
50104	2	1



12V + 6V
Hazard warning light switch, manufacturer Hella. Complete with mounting bracket for retrofitting. The hazard warning light switch is operated via the original flasher relay. Suitable light bulb: 50096 for 12 V. 14271 for 6 V.



Art.No.	Quality	needed qty
14374	2	1



Pull switch on/off



Art.No.	Quality	needed qty
50063	3	

Citroen 2CV + DS



Round pull switch for the windscreen wipers, a reproduction of the original switches from the 1970s! 2CV models from the years of construction 1962 to 1974, Citroën DS, HY



Art.No.	Quality	needed qty
14190	4	

www.franzose.com

FRENCH AUTOMOBILE CULTURE



0505 speedometer cable



Citroën 2CV >05/1958
DS 03/1958 > 1964
HY 03/1958>

Securing clip for the speedometer cable at the gearbox. For 2CV, Installed to year of construction 05/1958, Citroën DS and ID from 03.1958 to 1964, Citroën HY starting from year of construction 3/1958. Or. No. A381-96



Art.No.	Quality	needed qty
10474	1	1



Citroën HY

Speedometer cable complete. Suitable for Citroën HY. Length: 2350mm.



Art.No.	Quality	needed qty
48003	3	1



Citroën DS + HY

Speedometer cable above. Suitable for Citroën DS + Citroën HY. Length: 600mm. Or. No. 2D5415556P + DX52183 + HY52184



Art.No.	Quality	needed qty
30135	3	1



Speedometer cable down. Suitable for Citroën HY. Citroën 7CV + 11CV. Length: 1750mm. Or. No. HY52183



Art.No.	Quality	needed qty
48059	3	1



FRENCH AUTOMOBILE CULTURE



www.cipere.fr

www.franzose.de



www.franzose.com



Citroën DS + HY
90cm

Starter relay, mounted at the positive terminal of the battery. With 90cm cable. Suitable for Citroën DS (with left mounted battery) + Citroën HY. Or. No. 2D5401570T



Art.No.	Quality	needed qty
34071	3	1

Citroën

Battery bow spring, 5mm diameter. Suitable for Citroën 2CV, Mehari, Dyane, Ami, DS, HY. Or. No. AM53172

Art.No.	Quality	needed qty
35077	3	2





Citroën

Battery bow spring, 7mm diameter. Suitable for Citroën DS + HY.

D: 7,5mm



Art.No.	Quality	needed qty
35666	3	2

Citroën

Battery holding hook, 150mm long. M7 thread. Suitable for Citroën DS + HY.



Art.No.	Quality	needed qty
35664	3	2

Citroën

Battery holding hook, 185mm long. M7 thread. Suitable for Citroën DS + HY.

Art.No.	Quality	needed qty
35665	3	2

Citroën

Battery holding hook, 215mm long. M5 thread. Suitable for Citroën DS, HY, 2CV etc. also suitable for many Peugeot + Renault vehicles. Reproduction like original!

Art.No.	Quality	needed qty
35465	3	2



Peugeot, Citroën, Renault

Retaining brackets battery (universal), galvanized metal, typical for every french car of the fifties and sixties



Art.No.	Quality	needed qty
74211	3	1

Citroën HY

Battery box made of sheet metal. Suitable for Citroën HY. Very good reproduction! Ready to weld in!

Art.No.	Quality	needed qty
48402	3	1

12 Volt + 6 Volt

Battery charger - trickle charger for winter storage (OptiMate 1). Switchable between 6 volts and 12 volts. This small continuous charger is ideal for permanently connecting to a battery during the winter break. State-of-the-art technology protects against reverse polarity of the connections. It is suitable for normal lead batteries (those with acid). The maximum charging current is 0.6 amps. Please note: You cannot use this charger to quickly charge or reactivate empty batteries! It is therefore designed to keep the battery fresh and, if necessary, charge it very slowly. The scope of delivery also includes a charging cable that can be permanently connected to the battery. Simply route the plug connection to the outside and the charger can be connected without opening the bonnet.

Art.No.	Quality	needed qty
20566	1	1



12 Volt
Automatic

Battery charger for 12 volts (OptiMate 6 Ampmatic). Charging capacity: 6 amps. The 'Swiss Army knife' among battery chargers. You can connect all types of batteries (STD, AGM, EFB, GEL batteries). Almost all sizes can also be connected (3AH > 144Ah). This charger can even reactivate deeply discharged batteries (down to a discharge of 0.5 volts)! Its smart electronics make it possible. You can also test batteries. It has a safety circuit in case it is connected incorrectly. It controls the charging current according to the ambient temperature and has many other options. Whether it's a lawnmower, boat, car, motorhome, motorbike or tractor, this charger automatically adjusts to everything. And let's be honest, who knows what kind of battery is installed in modern vehicles these days? With this, it doesn't matter! Only modern electric vehicles cannot be charged with it! Of course, it can also be used as a normal battery maintenance charger. Our tip if you have several vehicles that are stored over the winter: get one of these chargers and equip the other vehicles with our maintenance chargers. The scope of delivery also includes a charging cable that can be permanently connected to the battery. Simply route the plug connection to the outside and the charger can be connected without opening the bonnet. Regular desulphation is important for a long service life of lead-acid batteries. And this is what these modern chargers can do.

Art.No.	Quality	needed qty
20567	1	1



- 1
- 2
- 3
- 4
- 5
- 6
- 7
- 8
- 9
- 10
- 11
- 12
- 13
- 14

0506 battery + holder

1
2
3
4
5
6
7
8
9
10
11
12
13
14



6Volt + 12 Volt
Battery charger for 6 volts + 12 volts (OptiMate 5 6V/12V). Charging capacity: 3 amps at 12 volts. 4 amps at 6 volts. This battery charger and trickle charger only charges lead-acid batteries (i.e. the batteries in classic cars). It can be used for both 6 volt and 12 volt batteries. This charger can also reactivate deeply discharged batteries (up to a discharge of 0.5 volts)! The clever electronics make it possible. You can also test batteries. It has a fuse circuit in case it is connected incorrectly. It controls the charging current according to the ambient temperature and has many other options. Regular desulphation is important for a long battery service life. And this is what these modern chargers can do.



Art.No.	Quality	needed qty
20568	1	1



Battery pole switch bent (space-saving). Just release knurled head bolt to stop current circuit. It can be very easily used when you do not use your car for long time (winter)! This switch replaces battery negative pole lead!



Art.No.	Quality	needed qty
14589	3	1



Battery pole switch. Just release knurled head bolt to stop current circuit. It can be very easily used when you do not use your car for long time (winter)! This switch replaces battery negative pole lead!



Art.No.	Quality	needed qty
14484	1	1

Coloured battery terminals. Red for positive. Black for negative. Suitable for all types. The risk of mixing up the terminals when connecting the battery is now minimised. These coloured battery terminal connectors are suitable for cables with a maximum diameter of 12 mm (cable cross-section up to 113 mm²). They fit terminal sizes of 16-19 mm. They are suitable for 6 V and 12 V batteries. And they look great too! Made in Germany

Art.No.	Quality	needed qty
14722	1	1



Battery pole negative -



Art.No.	Quality	needed qty
14119	3	1



Battery pole positive +



Art.No.	Quality	needed qty
14118	3	1



Battery pole plus + minus, with butterfly nut (colored in red + black). Universal suitable!



Art.No.	Quality	needed qty
85197	3	1



Battery pole protecting cap from rubber. Color: red. Length: 52mm. Width: 35mm. Short side - centric cable inlet.



Art.No.	Quality	needed qty
14555	3	1



Battery pole protecting cap from rubber. Color: red. Length: 52mm. Width: 35mm. Long side left - cable inlet down.



Art.No.	Quality	needed qty
14558	3	1



Battery pole protecting cap from rubber. Color: red. Length: 52mm. Width: 35mm. Long side on the right - cable inlet down.



Art.No.	Quality	needed qty
14556	3	1



Battery pole protecting cap from rubber. Color: black. Length: 52mm. Width: 35mm. Short side - centric cable inlet.



Art.No.	Quality	needed qty
14554	3	1



Battery pole protecting cap from rubber. Color: black. Length: 52mm. Width: 35mm. Long side on the right - cable inlet down.



Art.No.	Quality	needed qty
14557	3	1



Battery pole grease, 50g tube.



Art.No.	Quality	needed qty
20943	3	1



Battery terminals cleaning + milling cross. Indispensable for vintage cars! Trim once, and the electrical contact is back in order.



Art.No.	Quality	needed qty
20500	3	1



Distilled water, 1 litre



Art.No.	Quality	needed qty
20012	3	1



Ground cable 530mm long, universal fitting.



Art.No.	Quality	needed qty
14542	3	1



Ground cable (battery ground strap), with battery pole clamp and ring tongue. Length: 250mm. Cable diameter: 22mm². Made in the European Union. Universal fitting.



Art.No.	Quality	needed qty
14565	3	1



Earth cable (battery ground strap), with battery pole clamp and eye ring. Length: 285mm. Made one in the European Union. Universal fitting.



Art.No.	Quality	needed qty
14564	3	1



Ground cable (battery ground strap), with battery pole clamp and ring tongue. Length: 300mm. Cable diameter: 22mm². Made in the European Union. Universal fitting.



Art.No.	Quality	needed qty
14566	3	1



Ground cable (battery ground strap), with battery pole clamp ring tongue. Length: 350mm. Cable diameter: 22mm². Made in the European Union. Universal fitting.



Art.No.	Quality	needed qty
14567	3	1



Ground cable (battery ground strap), with battery pole clamp and ring tongue. Length: 400mm. Cable diameter: 22mm². Made in the European Union. Universal fitting.



Art.No.	Quality	needed qty
14568	3	1



Ground cable (battery ground strap), with battery pole clamp and ring tongue. Length: 500mm. Cable diameter: 22mm². Made in the European Union. Universal fitting.



Art.No.	Quality	needed qty
14570	3	1



Ground cable 500mm long, universal



Art.No.	Quality	needed qty
14460	3	1



Positive cable (battery to starter motor). Overall length: 500mm. Cable diameter: 16mm². Made in the European Union. Universal fitting.



Art.No.	Quality	needed qty
14561	3	1

DerFranzose
Citroën Peugeot Renault
www.franzose.com



0507 headlights + accessories + holder



High-grade steel nut for the securement of the headlamps on the headlamp carrier. Suitable for Citroën 2CV.



Art.No.	Quality	needed qty
14490	1	2

Citroën 2CV + HY



Washer conically, for the securement of the headlamps to the head light bracket. Per piece. Suitable for Citroën 2CV + HY. Or.Nr. 5443127



Art.No.	Quality	needed qty
16065	4	2

P45 > H4



Bulb adapter rings (2 pieces), from double filament bulb to H4. With this, every headlight that originally has a double filament bulb (P45) can be converted to an H4 bulb. You get much better light! Universal suitable.



Art.No.	Quality	needed qty
14687	3	1



Headlight plug (with long connection cable + round plugs), for Bilux or H4 bulb. Suitable for Citroën DS, Citroën 2CV, Citroën HY. Made in Germany.



Art.No.	Quality	needed qty
34051	3	2



Connector suitable for main headlights, for Citroën 2CV, Dyane, Ami6+8, HY. The plug is supplied with short cable ends and round plugs.



Art.No.	Quality	needed qty
14402	3	2



H4 connecting terminal with cable ends, universal.



Art.No.	Quality	needed qty
14440	3	2



12 Volt
big-bip-bip
peep-peep-peep
plep-plep-plep
LF15H

Light - buzzer. 12 V. Universal fitting. Simple installation.



Art.No.	Quality	needed qty
14176	1	1



Citroën 2CV4 + 2CV6
Citroën HY

Headlight mounting clamp (lever) on the top of the headlamp housing. Suitable for Citroën 2CV6, 2CV4, Citroën HY. Consisting of lever, spring, mounting plate.



NEW!

Art.No.	Quality	needed qty
14695	4	2



Headlamp chromi-plated with H4 reflector, for Citroën 2CV + HY. Reproduction from India! Original form, plastic case chrom-plated. Installed until 1990! Without bulbs.



Art.No.	Quality	needed qty
14405	4	2



remaining stock!
while stocks last!

Headlamp chrom-plated, with H4 reflector. Suitable for Citroën 2CV, HY. Original form, plastic case chrom-plated, like in the final years of construction installed. (up to year of construction 1990)! Original supplier Vaëo, no reproduction. Without bulbs. Production is stopped by Valeo! We took over the final 1800 headlamps from Valeo.



Art.No.	Quality	needed qty
14000	2	2



Headlamp trim ring (2 fittings), suitable for Citroën 2CV, to year of construction 1990, Citroën HY. Material: Aluminum. As replacement for the original ones.



Art.No.	Quality	needed qty
14069	4	1



Citroën 2CV + HY
H4

Headlight insert round, H4. Suitable for Citroën 2CV, HY. Per piece. Reproduction.



Art.No.	Quality	needed qty
14002	4	2



Citroën 2CV
Citroën HY

Headlamp casing rubber bushing down (for the cables). Suitable for Citroën 2CV + HY.



Art.No.	Quality	needed qty
12406	3	2



Citroën 2CV

Headlamp casing round, grounding, from synthetic. Version Cibie. Suitable for Citroën 2CV + HY. Installed from 1972 to 1990.



Art.No.	Quality	needed qty
14099	3	2



Citroën 2CV
Citroën HY

Headlamp casing round, chrom-plated, from synthetic. Suitable for Citroën 2CV, HY.



Art.No.	Quality	needed qty
14007	3	2



Marchal 640

Auxiliary headlight: Fog headlight small, type Marchal 640. Optically like original. Universal fitting. This headlamp was an original related accessory for Citroën 11CV.



Diameter: 140mm. The case is chromium-plated and made of metal. Without "E" test character! Suitable bulb 12 Volt= 14415, 14418, 14417. Bulb 6 V = 14178

Art.No.	Quality	needed qty
60703	3	2

turn signal, indoor lighting 0508



Indicator (reversing lamp) completely (clear), original Seima 3054. 3055 (no reproduction, with test symbol "E"). Metal base + metal support! The glass has 68,5mm diameter! Suitable for Citroën 2CV (in front), AZU + AK (in front), Mehari (in front + rear), DS BREAK (rear), HY (in front). Renault R4, early years of construction.



Art.No.	Quality	needed qty
14610	1	2



Side indicator on the wing (complete indicator). Exact copy of the original indicator. Used only in Italy and partly in Spain. These indicator were used on the Citroën 2CV, Mehari and DS. Partly also on Renault R4 and Peugeot 504. Outer diameter: 45mm. Overall height: 20mm. 2x fastening 4mm, at a distance of 30mm. Centre hole 15mm.



Art.No.	Quality	needed qty
14660	3	2



Indicator - buzzer. 12 V. Fits universal. So you never forget to turn off the switch from the indicator. Simple assembly: Connection: Parallel from the connection of the flasher relay (for flash control light) to the control light connection.



Art.No.	Quality	needed qty
14632	1	1

Citroën 2CV, Mehari, DS Renault R4 - Peugeot 504



Side indicator on the wing (only the cap). Exact copy of the original indicator. Used only in Italy and partly in Spain. These indicator were used on the Citroën 2CV, Mehari and DS. Partly also on Renault R4 and Peugeot 504.



Art.No.	Quality	needed qty
14661	3	2



Turn signals - Decorative rings for the front turn signals (2 pieces), for Citroën 2CV. Also suitable for the rear lights Citroën AZU, AK400, DS Break, HY, AMI6. Attention, the trim rings only fit on lights of the manufacturer "AXO". The Seima lamps are too flat. Own reproduction. Anodised aluminium.



Art.No.	Quality	needed qty
16855	1	1



Indicator seal for Seima indicators (the seal is located under the indicator base). Suitable for front indicators on 2CV, AZU + AK front + rear lighting, Mehari rear lighting. Citroën DS Break rear lighting, Citroën HY front + rear. Renault R4 front (1 version). Or. No. DJF544-144A.



Art.No.	Quality	needed qty
14466	3	2



Indicator complet (Reproduction, without "E" test mark), without fender fixture! Suitable for Citroën 2CV in front, DS BREAK rear, AK400 rear, AMI6 rear, HY rear, Mehari in front + rear. Version: AXO



Art.No.	Quality	needed qty
14009	3	2

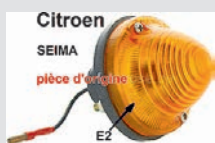

Indicator completely (Orange), original Seima 3054. 3055 (no reproduction, with test characters). Metal base + metal support! The glass has 68,5mm diameter! Suitable for Citroën 2CV (in front), AZU + AK (rear), Mehari (in front + rear), AMI6 (rear), DS BREAK (rear), HY (in front + rear). Renault R4, early years of construction.



Art.No.	Quality	needed qty
14609	1	2



Side indicator for the rear side at the front fender. Suitable for Citroën 2CV, Dyane, HY, DS. This indicator is serial installed in many south European countries (Italy, Spain etc.). Outside diameter inclusive chrome ring: 36,0mm.



Art.No.	Quality	needed qty
14593	3	2



Turn signal fixture in front on the left + in front on the right (2 pieces). Suitable for Citroën HY. Or. No. HY575-233A + HY575-234A



Art.No.	Quality	needed qty
44869	3	1



Turn signal lever solo, in brown(marron). Suitable for Citroën 2CV + Citroën HY. With the lever a broken indicator switch can be repaired.



Art.No.	Quality	needed qty
14596	3	1



Turn signal lever solo, in grey. Suitable for Citroën 2CV + Citroën HY. With the lever a broken indicator switch can be repaired.



Art.No.	Quality	needed qty
14595	3	1



Turn signal lever solo, in black. Suitable for Citroën 2CV + Citroën HY. With the lever a broken indicator switch can be repaired.



Art.No.	Quality	needed qty
14193	2	1



Indicator lever from synthetic, chrome-plated, for Citroën 2CV. With the lever a broken indicator switch can be repaired.



Art.No.	Quality	needed qty
14367	3	1

0508 turn signal, indoor lighting

1
2
3
4
5
6
7
8
9
10
11
12
13
14



Citroen
Turn signal cap yellow (Reproduction, without "E" test mark), suitable for in front 2CV, DS BREAK rear, AK rear, HY rear + in front, R4 old in front. Suitable for AXO lights. Wide light collar. Outside diameter 71mm, mounting holes center to center about 55mm, collar height from the inside measured: 14,5mm.



Art.No.	Quality	needed qty
14387	3	2



Citroen
Turn signal cap yellow (Reproduction, without "E" test mark), suitable for in front 2CV, DS BREAK rear, AK rear, HY rear + in front, R4 old in front. Suitable for Seima lights. Narrow light collar. Outside diameter 68mm, mounting holes center to center about 58mm, collar height from the inside measured: 10mm.



Art.No.	Quality	needed qty
14012	4	2



Citroen
Turn signal cap yellow (original AXO, with "E" test mark). Suitable for Citroën 2CV in front. Citroën DS BREAK rear. HY in front + rear. AMI6 rear. Renault R4 in front. Wide light collar. Outside diameter 71mm, mounting holes center to center about 55mm, collar height measured from the inside: 14,5mm. We could buy some thousand caps. No reproduction (NOS).



Art.No.	Quality	needed qty
14602	1	2



Citroen
Turn signal cap yellow (original SEIMA, with "E" test mark). Suitable for Citroën 2CV in front. Citroën DS BREAK rear. HY in front + rear. Renault R4 in front. Narrow light collar. Outside diameter 68mm. Mounting holes center to center about 58mm. Collar height measured from the inside: 10,0mm. We could buy some thousand caps. No reproduction (NOS).



Art.No.	Quality	needed qty
14605	1	2



Citroen
Turn signal cap clear (Reproduction, without "E" test mark), for 2CV / DS BREAK rear. Per piece. Version manufacturer Seima. 68,5mm outside diameter!



Art.No.	Quality	needed qty
14481	4	2



Citroen
Turn signal cap white (Reproduction, without "E" test mark), suitable for in front 2CV, DS BREAK rear, R4 old in front. Suitable for "AXO" lights. Outside diameter 70mm.



Art.No.	Quality	needed qty
14013	4	2



Citroen
Turn signal cap clear (original AXO, with "E" test mark). Suitable for Citroën 2CV in front. Citroën DS BREAK rear. HY in front + rear. Renault R4 in front. Wide light collar. Outside diameter 71mm, mounting holes center to center about 55mm, collar height measured from inside: 14,5mm. We could buy some thousand caps. No reproduction (NOS).



Art.No.	Quality	needed qty
14603	1	2



Citroen
Turn signal cap clear (original SEIMA, with "E" test mark). Suitable for Citroën 2CV in front. Citroën DS BREAK rear. HY in front + rear. Renault R4 in front. Narrow light collar. Outside diameter 68mm. Mounting holes center to center about 58mm. Collar height measured from the inside: 10,0mm. We could buy some thousand caps. No reproduction (NOS).



Art.No.	Quality	needed qty
14606	1	2



Citroen 2CV + HY
Turn signal switch at the steering column, color brown (Marron). Reproduction. Suitable for Citroën 2CV to year of construction 1990. Citroën HY



Art.No.	Quality	needed qty
14182	3	1



Citroen 2CV + HY
Turn signal switch at the steering column, color black. Reproduction. Suitable for Citroën 2CV to year of construction 1990. Citroën HY



Art.No.	Quality	needed qty
14181	3	1



Citroen 2CV + HY
Turn signal switch at steering column, color grey-white. Original Citroën. Suitable for Citroën 2CV. Citroën HY



Art.No.	Quality	needed qty
14122	3	1



Citroen 2CV + HY
Turn signal switch sheet metal holder for 2CV + HY



Art.No.	Quality	needed qty
14482	3	1



6 Volt 5 x 18/21W
6-volt electronic flasher relay. Power output from 10 watts to 110 watts! Branded product. This flasher relay is universally applicable for classic cars with 6-volt on-board voltage (Citroën 2CV, DS, HY, Renault R4, Renault with rear engines). It can also be used for operation with a trailer coupling!



Art.No.	Quality	needed qty
14366	1	1

12 Volt



Flasher relay for trailer operation, 12 volts. French version! Pin assignment for French: Power supply symbol (+). Front and rear indicator connection = C symbol. Dashboard control light = R symbol. Additional control light connection = R2. Negative ground = -. If a Japanese relay is used: Plus + = X or B symbol. Connection of these indicators C = symbol L. Connection of control R = symbol P. Connection of German relay: 31 = ground = must be laid. 49 = input voltage = +. 49a = output voltage to indicator = R. C = control light = C. C2 = additional control light for trailer operation



Art.No.	Quality	needed qty
14114	3	1

12 Volt



Indicator-flash relay round, electromechanical. 12 volts, max. 4x21 watt. 3 poles X/P/L !!! This flasher relay is electromechanical, not electronic! This makes it insensitive to voltage fluctuations and it still makes real click-click noises (like in the past). Suitable for Citroën 2CV, Dyane, Mehari, AMI, DS, HY. Peugeot + Renault. Power supply symbol (+, X or B). Connection turn signal front + rear = symbol (C or L). Connection indicator light dashboard = symbol (R or P). This flasher relay is made exclusively for us! Attention: Pay attention to the pin assignment of the relay. Do not simply change the plugs! The plug designation is also printed again on the housing!



Art.No.	Quality	needed qty
14361	3	1

12 Volt



Flasher relay, 12 V, 3 plug connections. 180 Watt power output. Suitable for Citroën 2CV, DS, HY. Renault R4, Peugeot 203, 403, 404 etc. The flasher relay does not make "click-click" noises. Connection French: Current supply symbol (+). Connection indicator in front + rear = symbol (C). Connection control light dashboard = symbol (R). If a Japanese relay is used: Plus + = symbol X or B. Connection indicator C = symbol L. connection control of R = symbol P.



Art.No.	Quality	needed qty
14112	3	1

Citroen



Electric contact for the round indicator or round tail lamp. Only for original old indicators, whose support are made of metal. Citroën 2CV indicator in front. AK-AZU indicator in front + rear. HY indicator in front + rear. DS BREAK rear. Mehari



Art.No.	Quality	needed qty
14663	4	2

Citroen
AMI8, ACDY, Dyane

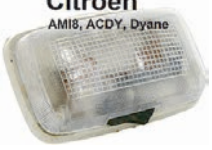

Interior light for Citroën AMI8, ACDY, Dyane. Citroën HY. Note: A lot of different lamps were obstructed, please compare the pictures. Or. No. AM 545-03C



Art.No.	Quality	needed qty
18193	4	1

Citroën
2CV, HY, DS



Screw for SEIMA turn signal cap + taillight cap. Suitable for Citroën 2CV. Citroën HY. Citroën DS BREAK. Or. No. AM544-17B



Art.No.	Quality	needed qty
16460	3	8

3,9x16



Screw cross lens head (3,9x16) from stainless steel, for round indicator + stop light. For Seima + AXO caps. Only suitable for synthetic bases. Per piece.



Art.No.	Quality	needed qty
21137	3	4

M4x10



Cross lens head screw (M4x10) from stainless steel, for round indicator + stop light. For Seima + AXO caps. Only suitable for metal bases. Per piece



Art.No.	Quality	needed qty
21138	3	4

M4x12



Cross lens head screw (M4x12) from high-grade steel, for round indicator + stop light. For Seima + AXO caps. Only suitable for metal bases. Per piece



Art.No.	Quality	needed qty
21139	3	4

12 Volt



Hazard warning lights switch 12 Volt! Manufacturer Bosch! The hazard flasher system uses the existing flasher relay and is relatively easy to install. Attention: a suitable bulb must be ordered separately. Our article number 14425.



Art.No.	Quality	needed qty
14659	2	1

6 Volt



Hazard warning lights switch 6 Volt! Manufacturer Bosch! The hazard flasher system uses the existing flasher relay and is relatively easy to install. Attention: a suitable bulb must be ordered separately. Our article number 14282.



Art.No.	Quality	needed qty
14218	2	1

12 Volt



Hazard warning signal switch, universal, 12volt, Manufacturer HELLA The switcher uses the actual indicator-relais. easy to fit.



Art.No.	Quality	needed qty
50104	2	1

12V + 6V



Hazard warning light switch, manufacturer Hella. Complete with mounting bracket for retrofitting. The hazard warning light switch is operated via the original flasher relay. Suitable light bulb: 50096 for 12 V. 14271 for 6 V.



Art.No.	Quality	needed qty
14374	2	1

0509 rear lighting

1
2
3
4
5
6
7
8
9
10
11
12
13
14



Indicator (reversing lamp) completely (clear), original Seima 3054. 3055 (no reproduction, with test symbol "E"). Metal base + metal support! The glass has 68,5mm diameter! Suitable for Citroën 2CV (in front), AZU + AK (in front), Mehari (in front + rear), DS BREAK (rear), HY (in front). Renault R4, early years of construction.



Art.No.	Quality	needed qty
14610	1	2



Indicator seal for Seima indicators (the seal is located under the indicator base). Suitable for front indicators on 2CV, AZU + AK front + rear lighting, Mehari rear lighting. Citroën DS Break rear lighting, Citroën HY front + rear. Renault R4 front (1 version). Or. No. DJF544-144A.



Art.No.	Quality	needed qty
14466	3	2



Indicator complet (Reproduction, without "E" test mark), without fender fixture! Suitable for Citroën 2CV in front, DS BREAK rear, AK400 rear, AMI6 rear, HY rear, Mehari in front + rear. Version: AXO



Art.No.	Quality	needed qty
14009	3	2



Indicator completely (Orange), original Seima 3054. 3055 (no reproduction, with test characters). Metal base + metal support! The glass has 68,5mm diameter! Suitable for Citroën 2CV (in front), AZU + AK (rear), Mehari (in front + rear), AMI6 (rear), DS BREAK (rear), HY (in front + rear). Renault R4, early years of construction.



Art.No.	Quality	needed qty
14609	1	2



Turn signal cap yellow (Reproduction, without "E" test mark), suitable for in front 2CV, DS BREAK rear, AK rear, HY rear + in front, R4 old in front. Suitable for AXO lights. Wide light collar. Outside diameter 71mm, mounting holes center to center about 55mm, collar height from the inside measured: 14,5mm.



Art.No.	Quality	needed qty
14387	3	2



Turn signal cap yellow (Reproduction, without "E" test mark), suitable for in front 2CV, DS BREAK rear, AK rear, HY rear + in front, R4 old in front. Suitable for Seima lights. Narrow light collar. Outside diameter 68mm, mounting holes center to center about 58mm, collar height from the inside measured: 10mm.



Art.No.	Quality	needed qty
14012	4	2



Turn signal cap yellow (original AXO, with "E" test mark). Suitable for Citroën 2CV in front. Citroën DS BREAK rear. HY in front + rear. AMI6 rear. Renault R4 in front. Wide light collar. Outside diameter 71mm, mounting holes center to center about 55mm, collar height measured from the inside: 14,5mm. We could buy some thousand caps. No reproduction (NOS).



Art.No.	Quality	needed qty
14602	1	2



Turn signal cap yellow (original SEIMA, with "E" test mark). Suitable for Citroën 2CV in front. Citroën DS BREAK rear. HY in front + rear. Renault R4 in front. Narrow light collar. Outside diameter 68mm. Mounting holes center to center about 58mm. Collar height measured from the inside: 10,0mm. We could buy some thousand caps. No reproduction (NOS).



Art.No.	Quality	needed qty
14605	1	2



Turn signal cap clear (Reproduction, without "E" test mark), for 2CV / DS BREAK rear. Per piece. Version manufacturer Seima. 68,5mm outside diameter!



Art.No.	Quality	needed qty
14481	4	2



Turn signal cap white (Reproduction, without "E" test mark), suitable for in front 2CV, DS BREAK rear, R4 old in front. Suitable for "AXO" lights. Outside diameter 70mm.



Art.No.	Quality	needed qty
14013	4	2



Turn signal cap clear (original AXO, with "E" test mark). Suitable for Citroën 2CV in front. Citroën DS BREAK rear. HY in front + rear. Renault R4 in front. Wide light collar. Outside diameter 71mm, mounting holes center to center about 55mm, collar height measured from inside: 14,5mm. We could buy some thousand caps. No reproduction (NOS).



Art.No.	Quality	needed qty
14603	1	2





Turn signal cap clear (original SEIMA, with "E" test mark). Suitable for Citroën 2CV in front. Citroën DS BREAK rear. HY in front + rear. Renault R4 in front. Narrow light collar. Outside diameter 68mm. Mounting holes center to center about 58mm. Collar height measured from the inside: 10,0mm. We could buy some thousand caps. No reproduction (NOS).





Art.No.	Quality	needed qty
14606	1	2

Citroen HY
Brake light switch (replacement). Suitable for Citroën HY.



Art.No.	Quality	needed qty
48397	3	1

Citroen 2CV, Dyane, DY, HY
Stop light switch at the brake pedal. Connection flat plug. Connector: M12x1. Suitable for Citroën 2CV6, DS, CX, BX, HY, GS



Art.No.	Quality	needed qty
14127	3	1

Stop light switch, suitable for Citroën 11CV/15CV, to year of construction 07/1952. Citroën HY, to year of construction 1963. Or. No. 712376



Art.No.	Quality	needed qty
60287	3	1

Citroen HY 01/1973 >
Stop light switch. Suitable for Citroën HY, to year of construction 01/1973. Original one, no reproduction (NOS). Or. No. HG576-02



Art.No.	Quality	needed qty
44011	1	1

Citroen
Electric contact for the round indicator or round tail lamp. Only for original old indicators, whose support are made of metal. Citroën 2CV indicator in front + rear. HY indicator in front + rear. DS BREAK rear. Mehari



Art.No.	Quality	needed qty
14663	4	2

Citroen
Electric contact for the round combined rear + brake lamp. Only for original old lights, whose support are made of metal. Citroën AK-AZU tail lamp. HY tail lamp. DS BREAK rear. Mehari.



Art.No.	Quality	needed qty
14664	4	2

Citroën 2CV <1963 Citroën HY
License plate light seal Citroën 2CV to year of construction 1963 + Citroën HY. Color grey!



Art.No.	Quality	needed qty
14290	4	2

Citroen 2CV > 1963 Citroen HY
License plate light cap (suitable for on the left, on the right + centrally) for Citroën 2CV to year of construction 1963 + Citroën HY. The cap is supplied without lower seal and support.



Art.No.	Quality	needed qty
14258	3	1

Citroën 2CV > 1954 AZU, HY
License plate light cap centrally. Suitable for Citroën 2CV, to year of construction 1954. AZU 250 + HY (early years of construction, license plates above over tail gate)



Art.No.	Quality	needed qty
14259	3	1

Citroën 2CV > 1963 AZU + HY
License plate light complete (1x set = 1x left + 1x right). Suitable for Citroën 2CV until year of construction 1963, AZU + HY. Colour: light grey. This set consists of 2 complete lights with bracket and seal.



Art.No.	Quality	needed qty
14261	3	1

Citroen 2CV > 1963 HY
License plate light completely, centrally (separable license plates), for Citroën 2CV to year of construction 1963 (diagonal tail sheet metal) + Citroën HY. Through seal and or paint from a side glass, can the light used also for on the left of or on the right. Colour: dark grey



Art.No.	Quality	needed qty
14260	3	1

Number plate light, with a black housing and flat mounting base. Suitable for Citroën AK, AZU, AC DY, HY, DS Break, Peugeot Pick Up...

Art.No.	Quality	needed qty
14685	3	1

License plate light, with black housing. Suitable for Citroën AK, AZU, AC DY, HY, DS BREAK.

Art.No.	Quality	needed qty
14547	3	1

Fog tail light, Hella. The is made from black plastic. Universal fitting. Width: 125mm. Height: 84mm.



Art.No.	Quality	needed qty
14098	2	1

Citroen HY + 11CV.... Peugeot 203, 403.... Renault Dauphine....
Park light, suitable for Citroën 11CV, HY. Peugeot 203, 403. Renault Dauphine etc. Per piece! Color: Red white. Installation opening diameter: 17,5mm. This light can also universal Installed. E.G. Citroën 2CV. Or. No. 721119



Art.No.	Quality	needed qty
60726	3	2

0509 rear lighting

1
2
3
4
5
6
7
8
9
10
11
12
13
14



Back-up light reproduction (Hella), the housing is made of plastic. Width 120mm, height of 70mm. The headlamp is for a later mounting underneath the bumper! It cannot be used as substitute for the original backup lights from R4! Lampholder for the bulb: Ba15s. Maximum 21Watt. (Our number 14035 + 14045).



Art.No.	Quality	needed qty
14051	3	1



Reversing lamp, manufacturer Hella. Chromed metal housing. Universal fitting.



Art.No.	Quality	needed qty
14027	1	1



Tail lamp and/or stop light round, original Seima 3054. 3055. (no reproduction, with test symbol "E") 1 thread light, only brake or taillight! With metal base + support! The glass has 68,5mm diameter! Used in HY, AZU, DS - in many Renault + Peugeot models as well!



Art.No.	Quality	needed qty
14478	2	4



Taillight + stop light, round, (2 thread light). 70mm diameter. Suitable for Citroën AK 400, DS BREAK, HY, Mehari. Version AXO! (suitable bulb: Item 14037). (Reproduction, without "E" test mark)



Art.No.	Quality	needed qty
14021	3	2



Taillight cap red (original AXO, with "E" test mark). Suitable for Citroën AK. Citroën DS BREAK. HY, Mehari, AMI6. Wide light collar. Outside diameter 71mm, mounting holes center to center about 55mm, collar level from the inside measured: 14,5mm. We could buy up some thousand caps. No reproduction (NOS).



Art.No.	Quality	needed qty
14604	1	2

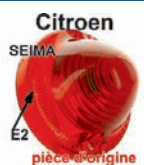

Taillight cap red (original SEIMA, with test characters). Suitable for Citroën AK. Citroën DS BREAK. HY, Mehari. Narrow light collar. Outside diameter 68mm. Mounting holes center to center about 58mm. Collar level from the inside measured: 10,0mm. We could buy up some thousand caps. No reproduction (NOS).



Art.No.	Quality	needed qty
14607	1	2



Taillight cap, red, round (Reproduction, without "E" test mark), for Citroën AK/AZU, DS Break, HY, Mehari, AMI6. AK544262A, for manufacturer Seima



Art.No.	Quality	needed qty
14221	4	2

60 x 45mm



Reflector square, framed in metal. With fixing straps, dimensions approx. 60x45mm. These reflectors were used in many French cars!



Art.No.	Quality	needed qty
14341	4	2



Reflector with locking collars. Suitable for Citroën AK, AZU, HY. Universal suitable for other classic cars. Diameter: 56mm.



Art.No.	Quality	needed qty
91049	4	2



Screw for SEIMA turn signal cap + taillight cap. Suitable for Citroën 2CV. Citroën HY. Citroën DS BREAK. Or. No. AM544-17B



Art.No.	Quality	needed qty
16460	3	8



Screw cross lens head (3,9x16) from stainless steel, for round indicator + stop light. For Seima + AXO caps. Only suitable for synthetic bases. Per piece.



Art.No.	Quality	needed qty
21137	3	4



Cross lens head screw (M4x10) from stainless steel, for round indicator + stop light. For Seima + AXO caps. Only suitable for metal bases. Per piece



Art.No.	Quality	needed qty
21138	3	4



Cross lens head screw (M4x12) from high-grade steel, for round indicator + stop light. For Seima + AXO caps. Only suitable for metal bases. Per piece



Art.No.	Quality	needed qty
21139	3	4



Hazard warning light switch, manufacturer Hella. Complete with mounting bracket for retrofitting. The hazard warning light switch is operated via the original flasher relay. Suitable light bulb: 50096 for 12 V. 14271 for 6 V.



Art.No.	Quality	needed qty
14374	2	1





Rubber bush, for the sheet metal holder of the wiper engine. Suitable for Citroën 11CV + 15CV, Citroën HY. Dimension: 15 x 10,5mm. Or. No. 721187



Art.No.	Quality	needed qty
60269	3	2



Return stop (valve) for fuel or windscreen washer fluid. Connection: 6 mm. This valve is a real improvement for classic vehicles that use a hand pump without a ball valve to deliver water. This ensures that windscreen washer fluid is always available at the spray nozzles. Please note the direction of flow during installation! It also prevents petrol from flowing back in the fuel line (useful for longer periods of inactivity). Please install this valve close to the petrol pump (between the petrol pump and the tank).



Art.No.	Quality	needed qty
75315	3	1



Windscreen washer reservoir - plastic bag with integrated electric water pump. 12 volts. The reservoir is supplied with mounting and accessories and can be installed in any vehicle, e.g. Citroën Mehari, Renault R4 first versions, etc. This type of windscreen washer reservoir has also been installed in many Italian vehicles (Alfa Romeo Spider...).



Art.No.	Quality	needed qty
16483	3	1



Washer reservoir electrical with built-in set for 2CV and other classical cars. Complete with push-button, cable, cross bars etc. very practical and small. Width 19,5cm, height of 16,5cm, depth 5,5cm



Art.No.	Quality	needed qty
14447	1	1



Washer reservoir with integrated, electrical water pump. 12 V. Capacity: 1.2 L. width: 122mm, overall height totally: 185mm. Building depth altogether: 100mm. The reservoir is supplied with fixture. The fixture is from the rear at the reservoir.



Art.No.	Quality	needed qty
75313	3	1



Washer reservoir original. Suitable for Citroën HY, AMI, GS. No reproduction!



Art.No.	Quality	needed qty
16140	1	1



Washer reservoir, rubber bushing above in the cap (for the hose). Suitable for Citroën DS, HY, 2CV etc. dimension: 5 x 18 x 4mm.



Art.No.	Quality	needed qty
35445	3	1



Wiper system nozzle - lower part, from brass. Suitable for Citroën DS, HY, 2CV etc.. Mounting diameter: 7,0mm.



Art.No.	Quality	needed qty
35446	3	1



Wiper system nozzle from grey synthetic. Suitable for Citroën HY. This nozzle is optically near at the original! Mounting diameter: 8,0mm.



Art.No.	Quality	needed qty
44831	3	2



Wiper nozzle cleaning and adjustment tool! Sturdy adjustment point, light cleaning stick. Both ends with end cap.



Art.No.	Quality	needed qty
20930	1	1



Windscreen washer nozzle black. Universal fitting. 4mm hose connection. The washer nozzle is screwed with a nut from behind. 2x water jet. Flat design.. Mounting diameter: 8,0mm.



Art.No.	Quality	needed qty
75312	3	1



Wiper system nozzles - upper part (with one water ejection nozzle)! Suitable for 2CV, Dyane, HY, DS (DS Installed to year of construction 1969!). M 7x1mm



Art.No.	Quality	needed qty
35449	3	1

Citroën DS



Wiper system nozzles - lower part, from brass. With additional connection for a hose. Suitable for Citroën DS, to year of construction 1969. In addition, this additional connection is very practical for Citroën DS, HY etc.. Mounting hole: 7,0mm.



Art.No.	Quality	needed qty
35447	3	1



Washer pump electrical. 12 V. Very stable version with galvanized metal fixture. 2x flat plug connection from above! Made in the European Union. The picture indicates the correct mounting position. The pump section is down, the electric motor above!



Art.No.	Quality	needed qty
75314	3	1

0511 washing system



12 Volt
Washer pump, electrically, color black. Suitable for Citroën DS. This pump is to be used also very well for conversion, e.g. 2CV, Dyane, Peugeot, Renault. Note: The pump is not self-priming. The water must run (from alone) inside. Outlet water = power connection side. If the pump works more than 15 seconds without water, it is broken.



Art.No.	Quality	needed qty
35473	3	1



Foot-operated pump set for windshield wiper fluid. Consisting of foot pump, 2 return flow stoppers, 1x T-valve, 3 meters hose. Assembly: Starting from the foot pump with the T-valve, 1x to the reservoir (place the valve in such a way that the water from the reservoir can pass through) and 1x to the windshield washer nozzle (valve lets the water pass in the direction of the nozzle). The flow directions are marked with an arrow on the valve. Assembly instruction online in the shop.



Art.No.	Quality	needed qty
75365	1	1



Disk washing water hand pump, reproduction, 5mm. This pump is mounted in the dashboard. In addition, the pump is a reproduction of the first version, and can be installed into a Citroën 2CV6 and partial in a Renault R4.



Art.No.	Quality	needed qty
18156	4	1



Windscreen washer hand pump with hose. Looks like the original. This pump is mounted in the dashboard. The pump corresponds to the original hand pump as it was mounted in the 2CV6 until the year of construction 1990. Or. No. AZ864-209A. This pump was also installed in the Citroën ID19 until the year of construction 1962 (DM564-9) and the Citroën HY. Please note: The pump has 3 connections: 1x inlet and 2x outlet. For the 2CV with the enclosed T-connector, please bridge 1x (see photo 2 in the shop).



Art.No.	Quality	needed qty
18048	3	1



Windscreen washing water hand pump. Reproduction, completely with sheet metal holder for a later mounting! Suitable for Citroën 2CV. In addition, the pump can be universal installed.



Art.No.	Quality	needed qty
18129	4	1



T-connector fuel pipe, 3mm, also suitable for the screen wash.



Art.No.	Quality	needed qty
10449	3	1



T-connector fuel pipe, 4mm, also suitable for screen wash.



Art.No.	Quality	needed qty
10446	3	1



T-connector for fuel pipe, 5mm, also suitable for the screen wash.



Art.No.	Quality	needed qty
10447	3	1



Renault
Water hose disk wiping water, rubber black! Inside diameter 3,5mm. By meters! Customer cut, return not possible!



Art.No.	Quality	needed qty
14544	3	1



Water hose screen wiping water, PVC clear. Inside diameter: 3mm, outside diameter: 5mm. Operating pressure maximum 7,5 bar. By meters. Custom cut, return not possible!



Art.No.	Quality	needed qty
14431	3	1

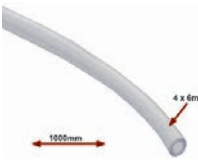

Water hose screen wiping water, PVC clear. Inside diameter: 4mm, outside diameter: 6mm. Operating pressure maximum 6,0 bar. By meters. Custom cut, return not possible!



Art.No.	Quality	needed qty
14432	3	1

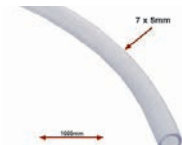

Water hose screen wiping water, PVC clear. Inside diameter: 5mm, outside diameter: 7mm. Operating pressure maximum 7,0 bar. By meters. Custom cut, return not possible!



Art.No.	Quality	needed qty
14433	3	1

Citroën 2CV



Wiper axle sealing rubber, under the chrome ring. Suitable for Citroën 2CV, HY.



Art.No.	Quality	needed qty
14154	3	2



2CV, HY
Wiper axle chrome ring, Citroën 2CV, HY. Is mounted over the sealing rubber of the wiper axle. Reproduction. Per piece.



Art.No.	Quality	needed qty
14247	4	2



Citroën 2CV DS / HY

Wiper axle connector nut outside. Suitable for Citroën 2CV, DS, HY. Nickel plates like original!



Art.No.	Quality	needed qty
14152	3	2



Citroën HY série 2 + 3

Wiper arm high-grade steel, befitting for Citroën HY series 2 + 3.



Art.No.	Quality	needed qty
48178	2	2



Citroën + Renault + Peugeot

Wiper blade elastic, per piece. Suitable for Citroën Dyane + ACDY, AMI6, Mehari, HY. Renault R4, Rodeo. Peugeot 403 + 404. 280mm lengthens. Original manufacturer Valeo! For 8mm of wide wiper arms.



Art.No.	Quality	needed qty
16018	2	2



Citroën Dyane Mehari HY

Wiper blade from high-grade steel, suitable for wiper arms 16378 + 16379, for Citroën Dyane + Acadyane, HY. Per piece. The wiper blade has a length of 265mm.



Art.No.	Quality	needed qty
16380	3	2



Wiper blade - windshield wiper. Length: 32cm. Material: stainless steel (not polished). For 6,0 - 6,5mm wide wiper arms with straight connection. Universal suitable. E.g. Citroën DS, AMI, CX, GS. Renault 5,6,12,15,16,17,18. Alpine A110 + 310. Peugeot 204,304,504 and many many other classics.



Art.No.	Quality	needed qty
75269	3	2



Wiper engine brushes for Citroën 2CV + HY, with angular wiper engine! 12 V.



Art.No.	Quality	needed qty
14358	3	1



Gear largely, for angular 12 V wiper engine, for Citroën 2CV. Or.Nr.A56524



Art.No.	Quality	needed qty
14379	3	1



Citroën 2CV

Gear small, for angular 12 V wiper engine, for Citroën 2CV. Or.Nr.V56523



Art.No.	Quality	needed qty
14373	3	1



0512 electrical component parts, other

1
2
3
4
5
6
7
8
9
10
11
12
13
14



12 Volt
12 Volt assembly socket to conversion (suitable for a cigarette lighter). Assembly orifice: 18mm.



Art.No.	Quality	needed qty
14439	3	1



12 Volt
12-volt cigarette lighter. Universally compatible. Installation opening: 27.5 mm. Good quality. Also ideal as a car socket for 12-volt devices.



Art.No.	Quality	needed qty
14641	3	1



12 Volt 30 Ampere
Operating circuit relay 12 Volt / 30 ampere of contact rating!



Art.No.	Quality	needed qty
14113	3	1



12 Volt
Indicator - buzzer. 12 V. Fits universal. So you never forget to turn off the switch from the indicator. Simple assembly: Connection: Parallel from the connection of the flasher relay (for flash control light) to the control light connection.



Art.No.	Quality	needed qty
14632	1	1



6 Volt 5 x 18/21W
6-volt electronic flasher relay. Power output from 10 watts to 110 watts! Branded product. This flasher relay is universally applicable for classic cars with 6-volt on-board voltage (Citroën 2CV, DS, HY, Renault R4, Renault with rear engines). It can also be used for operation with a trailer coupling!



Art.No.	Quality	needed qty
14366	1	1



12 Volt
Indicator-flash relay round, electromechanical. 12 volts, max. 4x21 watt. 3 poles X/P/L !!! This flasher relay is electromechanical, not electronic! This makes it insensitive to voltage fluctuations and it still makes real click-click noises (like in the past). Suitable for Citroën 2CV, Dyane, Mehari, AMI, DS, HY. Peugeot + Renault. Power supply symbol (+, X or B). Connection turn signal front + rear = symbol (C or L). Connection indicator light dashboard = symbol (R or P). This flasher relay is made exclusively for us! Attention: Pay attention to the pin assignment of the relay. Do not simply change the plugs! The plug designation is also printed again on the housing!



Art.No.	Quality	needed qty
14361	3	1



12 Volt
Flasher relay, 12 V, 3 plug connections. 180 Watt power output. Suitable for Citroën 2CV, DS, HY. Renault R4, Peugeot 203, 403, 404 etc. The flasher relay does not make "click-click" noises. Connection French: Current supply symbol (+). Connection indicator in front + rear = symbol (C). Connection control light dashboard = symbol (R). If a Japanese relay is used: Plus + = symbol X or B. Connection indicator C = symbol L. connection control of R = symbol P.



Art.No.	Quality	needed qty
14112	3	1



Citroën HY
Brake light switch (replacement). Suitable for Citroën HY.



Art.No.	Quality	needed qty
48397	3	1



Citroën 2CV, Dyane, DY, HY
Stop light switch at the brake pedal. Connection flat plug. Connector: M12x1. Suitable for Citroën 2CV6, DS, CX, BX, HY, GS



Art.No.	Quality	needed qty
14127	3	1



Citroën HY 01/1973 >
Stop light switch. Suitable for Citroën HY, to year of construction 01/1973. Original one, no reproduction (NOS). Or. No. HG576-02



Art.No.	Quality	needed qty
44011	1	1

Push button, starter button in red. As an alternative to the original thin starter buttons. Unfortunately, the original starter buttons are no longer available. Dimensions: Total diameter: 3cm. Overall height: 9cm.



Art.No.	Quality	needed qty
50060	3	1



Push button for starting knob. 22mm hole.



Art.No.	Quality	needed qty
50062	3	1



12 Volt
Universal electric attachment kit for tow bars. Includes relay for French cars. 12 volts. 7-pin socket. Additional control light. Hella flasher relay connection: terminal + = positive supply/terminal 30, corresponds to the + sign on the 2CV relay. Terminal C = output of the indicator relay to the front and rear indicators, corresponds to terminal C on the 2CV indicator relay! Terminal R = connection of the control light. Terminal R2 = connection of an additional control light. Terminal - = ground, must be bolted to the vehicle! The 2CV indicator relay does not have this connection!



Art.No.	Quality	needed qty
14115	3	1



Electrical mounting kit universal, for tow trailer coupling. Inclusive Relay for French car. 6 Volt. 7 pole plug socket. Additional control light. Connection of the Hella flashing relay: Clamp 49 = plus supply, corresponds + to indications on 2CV the relay. 49a = outlet flashing relay clamps to indicator in front + rear, clamp corresponds to C on 2CV flashing relays! C2 = connection clamps additional control light. Clamp 31 = earth, must be screwed on to vehicle! This port do not have the 2CV flashing relay! The original control light, in the vehicle, you must parallel on the clamp 49a scolded! Electronic kit universal for trailer towing device, incl. relay for French cars, 7 pole plug socket



Art.No.	Quality	needed qty
14688	3	1



Electrical wiring harness universal, for tow trailer coupling. Note: Only cables + socket! Without flasher, without control light. 7 cores.



Art.No.	Quality	needed qty
14151	4	1



Fanfare (horn). 2 fittings. 12 V.



Art.No.	Quality	needed qty
14185	2	1



Horn (12 V), completely with air compressor + 2 x compressed air horn, relay and air hoses. 750 + 800Hz (2 different tones). 115dB (A). Length of the air horns: 210 + 165mm. Length of the air compressor: about 105mm.



Art.No.	Quality	needed qty
75307	3	1



Horn (trumpet) 12 V, high tone. 480Hz, 108dB (A). Very high quality horn, made in the European Union. The horn is made of metal, with a red cover (trumpet) from plastic! Universal fitting. Diameter: about 110mm. ECE checked.



Art.No.	Quality	needed qty
14584	3	1



Horn (trumpet) 12 V, deep tone. 420Hz, 108dB (A). Very high-quality horn, made in the European Union. The horn is made of metal, with a red cover (trumpet) from red synthetic! Universal fitting. Diameter: about 110mm. ECE checked.



Art.No.	Quality	needed qty
14585	3	1



Horn, 12V. Universal fitting.



Art.No.	Quality	needed qty
14153	3	1



Horn 12 V, high tone. 430Hz, 114dB (A). Very high quality horn, made in the European Union. The horn is from the front in red painted! Universal fitting. Diameter: about 91mm. Metal housing. ECE checked.



Art.No.	Quality	needed qty
14580	3	1



Horn 12 V, deep tone. 340Hz, 114dB (A). Very high quality horn, made in the European Union. The horn is from the front in red painted! Universal fitting. Diameter: about 91mm. Metal housing. ECE checked.



Art.No.	Quality	needed qty
14581	3	1



Horn 6 V. Universal suitable. Diameter: About 100mm. Completely made from metal.



Art.No.	Quality	needed qty
90917	3	1



Horn chromium-plates. 6 Volt! Very heavy version. Suitable for Citroën 11CV, HY, 2CV. Diameter: 125mm. Height over everything: 80mm.



Art.No.	Quality	needed qty
60816	3	1



Horn, 12Volt. Universal fitting. Diameter 100mm! The horn is chromium-plated.



Art.No.	Quality	needed qty
14160	4	1



Horn set (2 pieces) chromium-plated, from Bosch. Frequencies: 325 and 400 Hertz. Volume: 118 db(A), operating voltage: 12 V, power consumption: 48 W each, diameter: 156 mm, depth: 91 mm, EMV protection: included. Universal fitting.



Art.No.	Quality	needed qty
14491	2	1



Cable 1,5qmm (car cable). Color green. By meters. Customer cut, return not possible!



Art.No.	Quality	needed qty
20117	3	1



Insulated cable plug, with 2 connectors (to combine connections). From 1 cable to 1 cable



Art.No.	Quality	needed qty
20177	3	1



0512 electrical component parts, other

1
2
3
4
5
6
7
8
9
10
11
12
13
14





Insulated cable plug, from 1 cable to 1 cable

Art.No.	Quality	needed qty
20178	3	

Cable connectors, isolated from 1 cable to 2 cables

Art.No.	Quality	needed qty
20176	3	

160x
Cable connector set, 160 pieces.

Art.No.	Quality	needed qty
20136	3	





Toggle switch with polished head. Version: Changeover switch. 3x electrical connection. Load capacity: 5 amps. Bore diameter: 12.5mm. This switch is a changeover switch. You can therefore switch 2 functions. But of course it can also be used as a normal toggle switch. Then only 2 electrical connections are connected.

Art.No.	Quality	needed qty
50061	3	





On + Off
Toggle actuator universal. On - Off. Material: Plastic black.

Art.No.	Quality	needed qty
14124	3	



6 + 12 Volt
Control light green, turn light indicator to use with a tow trailer coupling. 12 V.

Art.No.	Quality	needed qty
14167	3	1



12 Volt
Light - buzzer. 12 V. Universal fitting. Simple installation.

Art.No.	Quality	needed qty
14176	1	1



Metal plug, seven poles, for the trailer

Art.No.	Quality	needed qty
14116	3	1



Plug socket, metall, seven poles, at trailer towing coupling

Art.No.	Quality	needed qty
14117	3	1



Multimeter digital. Dimension: 74x145x40mm. Measuring range: Volt direct current + alternating current. Ampere, resistance, continuity tester. Everything what you need, for car electrical connection.

Art.No.	Quality	needed qty
20147	1	1



6 - 24 Volt
Test lamp for car, 6-24 V.

Art.No.	Quality	needed qty
20126	3	1



Fuse assortment.

Art.No.	Quality	needed qty
75321	3	1

10A
Glass fuse 10A, 6,3 x 32 mm

Art.No.	Quality	needed qty
14131	3	



15A
Glass fuse 15A. 6,3 x 32 mm

Art.No.	Quality	needed qty
14132	3	

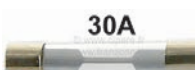

30A
Glass fuse 30A, 6,3 x 32 mm

Art.No.	Quality	needed qty
14133	3	



Citroen
Fuse holder (cable shoe). High-quality reproduction of the original fixture, which never was available from Citroën. Made in Germany.

Art.No.	Quality	needed qty
14608	3	



16 ampere fuse with screw-connections, optimal to protect additional loads (devices). The housing can be equipped with other fuse strengths (ratings).

Art.No.	Quality	needed qty
14339	3	1

6x3 x 32mm
Fuse set (glass fuse).Contents: 1x 5A, 10A , 15A, 20A, 30A (amps) each. Dimension: 6,3 x 32mm. Complete in an outer packaging (ideal for the 2CV, DS, HY... travel kit!).

Art.No.	Quality	needed qty
14139	3	1

USB-C + USB-A
USB A+C adapter (12 volt) for cigarette lighter. The adapter has 2 connections. 1x USB-A (the large wide plug) and 1x UBB-C (the new small plugs).

Art.No.	Quality	needed qty
14658	3	1



0512 electrical component parts, other

0 = New old stock
1 = Good
2 = Original
3 = Advanced replica
4 = Replica
5 = Mediocre replica



Adapter cable for classical radios. From DIN connection on 3,5mm cinch. So, you can connected very simply MP3 player, Smartphones etc. Suitable for all classical Blaupunkt radios supplied by us.



Art.No.	Quality	needed qty
18505	1	1



Roof antenna with spring mounting (spiral), suitable for Citroën DS. This antenna is also universal applicable. Length about: 870mm. Reproduction



Art.No.	Quality	needed qty
35619	3	1



Antenna, for installation on top of the fender (it does not work on the side). Very significant and beautiful flagpole antenna from Europe. The flagpole antenna is from high-grade steel. Required drill hole: 12.0mm. Length (depth) of the antenna tube in the wing: 260mm. Antenna extended: 900mm.



Art.No.	Quality	needed qty
75306	3	1



Recessed loudspeaker, very flat construction height (scope of delivery: 1 piece). Installation depth only 30mm! Diameter 143mm. 40 Watt. 4 Ohm. Suitable for door panels of Citroën 2CV, Renault R4, Peugeot 204 - 504..... Particularly flat design, therefore super suitable for door panels (also Citroën 2CV + Renault R4). Outer diameter = 143 mm, cut-out for installation opening in the door panels = 120 - 130mm. Dualcone loudspeaker.



Art.No.	Quality	needed qty
18161	3	2



Antenna, for the lateral attachment at A-post. These antennas were installed with many French vehicles. E.G. with Citroën 2CV, Renault R4, Citroën HY etc.



Art.No.	Quality	needed qty
14141	4	1



Car deck speaker pair with 7 cm round casing, bracket included. Black color. Diameter: 104mm. Overall length: 113mm. These retro stereo speakers with plastic casing have been specifically conceived as universal mid-and high-range loudspeakers for vintage cars. Many classic cars can only be equipped with mono speakers. This new 70mm broadband loudspeaker can be directly operated with a car stereo.



Art.No.	Quality	needed qty
18557	3	1



Car deck speaker pair with 7 cm round casing, bracket included. Chrome-colored. Diameter: 104mm. Overall length: 113mm. These retro stereo speakers with plastic casing have been specifically conceived as universal mid-and high-range loudspeakers for vintage cars. Many classic cars can only be equipped with mono speakers. This new 70mm broadband loudspeaker can be directly operated with a car stereo.



Art.No.	Quality	needed qty
18558	3	1



Square surface speaker with chrome-plated surface. Universal fitting. Per piece. Outer dimensions approx. 175x128mm. The loudspeaker is diagonal, front height 60mm, rear height 80mm.



Art.No.	Quality	needed qty
18512	3	2



Loudspeaker cover chrome, angularly, 120x160mm. Universal fitting. Per piece



Art.No.	Quality	needed qty
18510	3	1



Loudspeaker cover chrome, angularly, 160x200mm. Universal fitting. Per piece



Art.No.	Quality	needed qty
18511	2	1



Loudspeaker cover chrome, round, 130mm, universal fitting, per piece.



Art.No.	Quality	needed qty
18508	3	1



Console for a radio in DIN measurements. The console is mounted under the dashboard. Universal fitting, e.g. Citroën 2CV, DS. Dimension cutout for radio: 182 x 53mm. Dimension outside: Height: 76mm. Wide above 250mm (down 220mm). Deep one: 175mm.



Art.No.	Quality	needed qty
18045	3	1



0514 ignition locks



Citroën 2CV
Mehari, HY
2CV old/Mehari/HY, door lock, lockcylinder set for old 2CV + Mehari, HY. 2x door lock (round pin) + 1x starter lock (angular pin)! With vehicles with starter button!



Art.No.	Quality	needed qty
16187	2	1



Citroën 2CV + HY
Starter lock in the dashboard. Suitable for Citroën 2CV + HY. Inclusive 2 keys. The lock has 2x mounting thread M5 x 0.80 (ISO standard metrically). In the old Citroën is often M5 x 0.75 installed. Use please 2 suitable screws!



Art.No.	Quality	needed qty
14613	3	1



Citroën 2CV
DS + 1967 / AMI6 / HY
Ignition lock in the dashboard, for Citroën 2CV with starter button (with 2 connections). The ignition lock also fits in the Citroën DS until 1967, AMI6 and Citroën HY. Reproduction, incl. 2 keys.



Art.No.	Quality	needed qty
14236	4	1



Citroën 2CV, DS, HY
Ignition lock key blank, suitable for Citroën 2CV, DS, HY. (small version, ignition key has the size of door keys, for vehicles with starter button). Shaft length: 17,3mm. Shaft width: 7,0mm.



Art.No.	Quality	needed qty
14142	2	1



Citroën 2CV
DS + 1967 / AMI6 / HY
Ignition lock in the dashboard, for Citroën 2CV with starter button (with 4 connections). The ignition lock also fits in the Citroën DS until 1967, AMI6 and Citroën HY. Reproduction, incl. 2 keys.



Art.No.	Quality	needed qty
16678	4	1



Citroën DS > 1968
Citroën HY
Ignition lock, suitable for Citroën DS, up to year of construction 1968. Citroën HY. True to original reproduction. Or. No. DW21214C



Art.No.	Quality	needed qty
33188	3	1



FRENCH AUTOMOBILE CULTURE



www.cipere.fr

www.franzose.de

www.franzose.com

6

bumpers

front bumper	0601
rear bumper	0602

FRENCH AUTOMOBILE CULTURE



Convert inch / millimeter

Table de conversion : Pouces / Millimètre | Umrechnung Zoll/inch / Millimeter

Zoll/Inch Pouces Inches	Zoll/Inch valeur décimale decimal	mm métrique metric system
1/64"	0,016"	0,397 mm
1/32"	0,031"	0,794 mm
1/16"	0,063"	1,587 mm
1/8"	0,125"	3,175 mm
1/4"	0,250"	6,350 mm
3/8"	0,375"	9,525 mm
1/2"	0,500"	12,700 mm
5/8"	0,625"	15,875 mm
3/4"	0,750"	19,050 mm
7/8"	0,875"	22,225 mm
1"	1,000"	25,400 mm
1 1/4"	1,250"	31,750 mm
1 1/2"	1,500"	38,100 mm
1 3/4"	1,750"	44,450 mm
2"	2,000"	50,800 mm
2 1/4"	2,250"	57,150 mm
Zoll = Zentimeter / 2,54		

Zoll/Inch Pouces Inches	Zoll/Inch valeur décimale decimal	mm métrique metric system
2 1/2"	2,500"	63,500 mm
2 3/4"	2,750"	69,850 mm
3"	3,000"	76,200 mm
3 1/4"	3,250"	82,550 mm
3 1/2"	3,500"	88,900 mm
3 3/4"	3,750"	95,250 mm
4"	4,000"	101,600 mm
4 1/4"	4,250"	107,950 mm
4 1/2"	4,500"	114,300 mm
4 3/4"	4,750"	120,650 mm
5"	5,000"	127,000 mm
6"	6,000"	152,400 mm
7"	7,000"	177,800 mm
8"	8,000"	203,200 mm
9"	9,000"	228,600 mm
10"	10,000"	254,000 mm
Zentimeter = Zoll * 2,54		

UNF-Thread (USA) Unified National Fine

thread designation	Outside diameter in inches	Outside diameter in mm	aisles in inches	slope in mm
1/4" - 28 UNF	0,250	6,350	28	0,907
5/16" - 24 UNF	0,313	7,938	24	1,058
3/8" - 24 UNF	0,375	9,525	24	1,058
7/16" - 20 UNF	0,438	11,112	20	1,270
1/2" - 20 UNF	0,500	12,700	20	1,270
9/16" - 18 UNF	0,563	14,288	18	1,411
5/8" - 18 UNF	0,625	15,875	18	1,411
3/4" - 16 UNF	0,750	19,050	16	1,587



Autosol chrome polish. 75 ml tube. (Premium chrome shine care). Autosol chrome polish has been around for ages and has often been copied! Made in Germany.



Art.No.	Quality	needed qty
20968	2	1



14 x 14mm

Box nut M7 (casing nut 14 x 14mm). Suitable for Citroën 2CV (in front at the original chassis. Fixture head light bracket - bumper mounting bracket)



Art.No.	Quality	needed qty
21057	3	2



Bumper in front (old design), reproduction (the bumper must be painted!). Suitable for Citroën HY, to year of construction 1963.



Art.No.	Quality	needed qty
48380	4	1



Bumper in front, reproduction (the bumper must be painted!). Suitable for Citroën HY.



Art.No.	Quality	needed qty
48213	4	1



www.cipere.fr

www.franzose.de

www.franzose.com



0602 rear bumper



Autosol chrome polish. 75 ml tube. (Premium chrome shine care). Autosol chrome polish has been around for ages and has often been copied! Made in Germany.



Art.No.	Quality	needed qty
20968	2	1



Bumper rear, first version. "CITROËN" emblem (signature), which is mounted between the two trims. The signature is out of sheet metal. Installed at Citroën 2CV up to year of construction 1961. Also partly at Citroën 11CV + HY.



Art.No.	Quality	needed qty
16887	4	1



Bumper rear. Suitable for Citroën HY. Reproduction, must be painted!



Art.No.	Quality	needed qty
48233	4	1



Bumper bow rear (1 piece). Suitable for Citroën HY, up to year of construction 09/1965. Or. No. H663-99



Art.No.	Quality	needed qty
44843	3	2



Bumper bows rear: Mounting reinforcing plate (at the rear crossbeam). Suitable for Citroën HY, to year of construction 1963.



Art.No.	Quality	needed qty
48379	3	2



7

vehicle body

chassis	0701
rear body components	0702
floor panels	0703
welded body components	0704
doors front + rear + attachments	0705
luggage compartment lid + attachments, rear do.	0706
emblems	0707
front wing	0708
rear wing	0709
engine bonnet + front panels + radiator grille	0710
body seals	0711
door locks + handles	0712
door pane + attachments	0713
remaining glazing	0714
top + soft top hoods	0715
tow coupling + accessories	0717
mirror	0718
decoration sets (glue sets)	0719



	<p>Battery box made of sheet metal. Suitable for Citroën HY. Very good reproduction! Ready to weld in!</p>							
<table border="1"> <thead> <tr> <th>Art.No.</th> <th>Quality</th> <th>needed qty</th> </tr> </thead> <tbody> <tr> <td>48402</td> <td>3</td> <td>1</td> </tr> </tbody> </table>	Art.No.	Quality	needed qty	48402	3	1		
Art.No.	Quality	needed qty						
48402	3	1						
	<p>Cross-beam left, sheet metal under the cab, connection to the chassis cross-beam (horizontal) and cross-beam under the cab (vertical). Suitable for Citroën HY.</p>							
<table border="1"> <thead> <tr> <th>Art.No.</th> <th>Quality</th> <th>needed qty</th> </tr> </thead> <tbody> <tr> <td>44925</td> <td>3</td> <td>1</td> </tr> </tbody> </table>	Art.No.	Quality	needed qty	44925	3	1		
Art.No.	Quality	needed qty						
44925	3	1						
	<p>Cross-beam left, under the vehicle floor. At the height of the rear axle. Suitable for Citroën HY. With all reinforcements. Length: approx. 120cm.</p>							
<table border="1"> <thead> <tr> <th>Art.No.</th> <th>Quality</th> <th>needed qty</th> </tr> </thead> <tbody> <tr> <td>44841</td> <td>3</td> <td>1</td> </tr> </tbody> </table>	Art.No.	Quality	needed qty	44841	3	1		
Art.No.	Quality	needed qty						
44841	3	1						
	<p>Cross-beam on the left, under the complete vehicle floor (total length). Suitable for Citroën HY (standard wheelbase). With all reinforcements. Dimension: 2460 x 260/180 x 1.5mm</p>							
<table border="1"> <thead> <tr> <th>Art.No.</th> <th>Quality</th> <th>needed qty</th> </tr> </thead> <tbody> <tr> <td>44923</td> <td>3</td> <td>1</td> </tr> </tbody> </table>	Art.No.	Quality	needed qty	44923	3	1		
Art.No.	Quality	needed qty						
44923	3	1						
	<p>Cross-beam right, sheet metal under the cab, connection to the chassis cross-beam (horizontal) and cross-beam under the cab (vertical). Suitable for Citroën HY.</p>							
<table border="1"> <thead> <tr> <th>Art.No.</th> <th>Quality</th> <th>needed qty</th> </tr> </thead> <tbody> <tr> <td>44926</td> <td>3</td> <td>1</td> </tr> </tbody> </table>	Art.No.	Quality	needed qty	44926	3	1		
Art.No.	Quality	needed qty						
44926	3	1						
	<p>Cross-beam right, under the vehicle floor. At the height of the rear axle. Suitable for Citroën HY. With all reinforcements. Length: approx. 120cm.</p>							
<table border="1"> <thead> <tr> <th>Art.No.</th> <th>Quality</th> <th>needed qty</th> </tr> </thead> <tbody> <tr> <td>44842</td> <td>3</td> <td>1</td> </tr> </tbody> </table>	Art.No.	Quality	needed qty	44842	3	1		
Art.No.	Quality	needed qty						
44842	3	1						
	<p>Cross-beam on the right, under the complete vehicle floor (total length). Suitable for Citroën HY (standard wheelbase). With all reinforcements. Dimension: 2460 x 260/180 x 1.5mm</p>							
<table border="1"> <thead> <tr> <th>Art.No.</th> <th>Quality</th> <th>needed qty</th> </tr> </thead> <tbody> <tr> <td>44924</td> <td>3</td> <td>1</td> </tr> </tbody> </table>	Art.No.	Quality	needed qty	44924	3	1		
Art.No.	Quality	needed qty						
44924	3	1						
	<p>M5 weld nut (spot weld nut), like original! Suitable for Citroën 2CV, DS, HY</p>							
<table border="1"> <thead> <tr> <th>Art.No.</th> <th>Quality</th> <th>needed qty</th> </tr> </thead> <tbody> <tr> <td>21081</td> <td>3</td> <td></td> </tr> </tbody> </table>	Art.No.	Quality	needed qty	21081	3			
Art.No.	Quality	needed qty						
21081	3							

	<p>Box nut M7 (casing nut 14 x 14mm). Suitable for Citroën 2CV (in front at the original chassis. Fixture head light bracket - bumper mounting bracket)</p>							
<table border="1"> <thead> <tr> <th>Art.No.</th> <th>Quality</th> <th>needed qty</th> </tr> </thead> <tbody> <tr> <td>21057</td> <td>3</td> <td>2</td> </tr> </tbody> </table>	Art.No.	Quality	needed qty	21057	3	2		
Art.No.	Quality	needed qty						
21057	3	2						
	<p>M7 weld nut (spot weld nut), like original! Suitable for Citroën 2CV, DS, HY</p>							
<table border="1"> <thead> <tr> <th>Art.No.</th> <th>Quality</th> <th>needed qty</th> </tr> </thead> <tbody> <tr> <td>21080</td> <td>3</td> <td></td> </tr> </tbody> </table>	Art.No.	Quality	needed qty	21080	3			
Art.No.	Quality	needed qty						
21080	3							
	<p>Box nut M9 (casing nut). 17 x 17mm</p>							
<table border="1"> <thead> <tr> <th>Art.No.</th> <th>Quality</th> <th>needed qty</th> </tr> </thead> <tbody> <tr> <td>21066</td> <td>3</td> <td></td> </tr> </tbody> </table>	Art.No.	Quality	needed qty	21066	3			
Art.No.	Quality	needed qty						
21066	3							



- 1
- 2
- 3
- 4
- 5
- 6
- 7
- 8
- 9
- 10
- 11
- 12
- 13
- 14

0702 rear body components

1
2
3
4
5
6
7
8
9
10
11
12
13
14



Citroën AK
AZU, ACDY, HY

AK400/ACDY/AZU/HY, spare wheel hood, spring for the latching pin.

Art.No.	Quality	needed qty
15423	4	2



Citroën HY

Rear end panel, under the tail gates (outer sheet metal with reinforcement!). Suitable for Citroën HY.

Art.No.	Quality	needed qty
48214	4	1



AK, AZU, ACDY, HY



AK/AZU/ACDY/HY, spare wheel hood, actuation handle for the latching pin.

Art.No.	Quality	needed qty
15424	4	2



Citroën HY

Tail sheet metal on the left + on the right for increase of the roof (175mm highly). This sheet metals are welded on the original tail sheet metal! (1 pair)

Art.No.	Quality	needed qty
48258	3	1



AK, AZU, ACDY, HY

AK/AZU/ACDY/HY, latching pins for the spare wheel hood.

Art.No.	Quality	needed qty
15422	4	2



Citroën HY

Tail sheet metal on the left down (without cross-beam on the rear side). Suitable for Citroën HY, to year of construction 07/1961. Or. No. HP823-2A

Art.No.	Quality	needed qty
44844	3	1



Citroën HY

Aluminum edging profile (1000mm)for the side metal sheets in the box body. Fits to Citroën HY, first model. Original sheets were just screwed. These profiles are made of aluminum! For a classic HY version you need: 2x 2400mm, 2x 1630mm, 4x 630mm. Item n° 48262 is 1500 mm profile. Item n° 48263 is 1000 mm profile.

Art.No.	Quality	needed qty
48263	3	10



Citroën HY

Tail sheet metal on the left extends, only outer sheet metal. Suitable for Citroën HY with increased body!

Art.No.	Quality	needed qty
48251	3	1



Citroën HY

Aluminum edging profile (1500mm)for the side metal sheets in the box body. Fits to Citroën HY, first model. Original sheets were just screwed. These profiles are made of aluminium! For a classic HY version you need: 2x 2400mm, 2x 1630mm, 4x 630mm. Item n° 48262 is 1500 mm profile. Item n° 48263 is 1000 mm profile.

Art.No.	Quality	needed qty
48262	3	2



Citroën HY

Tail sheet metal on the left, only outer sheet metal. Complete height for a normal Citroën HY, Installed starting from 9/1963.

Art.No.	Quality	needed qty
48248	3	1



Citroën HY

Profile for the transition from driver's cabin roof to box body. This profile was mounted with the normal box body and also with vehicles with increased box body. Suitable for Citroën HY. Or.Nr. H824-99

Art.No.	Quality	needed qty
48260	3	1



Citroën HY

Tail sheet metal on the left, only increase (+17,5cm). Suitable for Citroën HY, if the body is to be increased.

Art.No.	Quality	needed qty
48346	3	1



Citroën HY >1963

Rear end panel cross-beam completely. Suitable for Citroën HY to year of construction 1963. The cross-beam is supplied inclusive the bumper bows.

Art.No.	Quality	needed qty
44892	3	1



Citroën HY

Tail sheet metal on the left. Mounting for the tail lamps. Suitable for Citroën HY. It is the external sheet metal, with cross-beams. Length about 600mm.

Art.No.	Quality	needed qty
48169	3	1



Citroën HY

Rear end panel cross-beam completely. Suitable for Citroën HY, with rear bumper (not suitable for HY with pipe bow). Or. No. HY744-67

Art.No.	Quality	needed qty
48340	3	1



Citroën HY

Tail sheet metal on the left. Mounting for the tail lamps. Suitable for Citroën HY. It is only the external sheet metal, without cross-beams. Length about 1000mm.

Art.No.	Quality	needed qty
48093	4	1







Citroën HY Pick Up
Tail sheet metal on the left. Suitable for Citroën HY Pick UP, starting from year of construction 1963. The tail sheet metal fits for the original AXO lights and has a projection for the license plate light.



Art.No.	Quality	needed qty
48363	3	1



Citroën HY Pick Up 1963 >
Tail sheet metal on the left. Suitable for Citroën HY Pick UP, starting from year of construction 1963. The tail sheet metal fits for the original AXO lights!



Art.No.	Quality	needed qty
48349	3	1



Citroën HY Pick Up
Tail sheet metal on the left. Suitable for Citroën HY Pick UP, starting from year of construction 1963. The tail sheet metal is without hatches for tail lamps, but with projection for a license plate light.



Art.No.	Quality	needed qty
48367	3	1



Citroën HY Pick Up 1963 >
Tail sheet metal on the left. Suitable for Citroën HY Pick UP, starting from year of construction 1963. The tail sheet metal is without lamp bores for tail lamps.



Art.No.	Quality	needed qty
48351	3	1



Citroën HY
Tail sheet metal crosswise above, for Citroën HY. All year of construction. Or.Nr. HY 823-95.



Art.No.	Quality	needed qty
48250	3	1



Citroën HY
Tail sheet metal on the right down (without cross-beam on the rear side). Suitable for Citroën HY, to year of construction 07/1961. Or. No. HP823-3A



Art.No.	Quality	needed qty
44845	3	1



Citroën HY
Tail sheet metal on the right extends, only outer sheet metal. Suitable for Citroën HY with increased body!



Art.No.	Quality	needed qty
48252	3	1



Citroën HY
Tail sheet metal on the right, only outer sheet metal. Complete height for a normal Citroën HY, Installed starting from 9/1963.



Art.No.	Quality	needed qty
48249	3	1



Citroën HY
Tail sheet metal on the right, only increase (+17,5cm). Suitable for Citroën HY, if the body is to be increased.



Art.No.	Quality	needed qty
48347	3	1



Citroën HY
Tail sheet metal on the right. Mounting for the tail lamps. Suitable for Citroën HY. It is the external sheet metal, with cross-beams. Length about 600mm.



Art.No.	Quality	needed qty
48168	3	1



Citroën HY
Tail sheet metal on the right. Mounting for the tail lamps. Suitable for Citroën HY. It is only the external sheet metal, without cross-beams. Length about 1000mm.



Art.No.	Quality	needed qty
48094	4	1



Citroën HY Pick Up 1963 >
Tail sheet metal on the right. Suitable for Citroën HY Pick UP, starting from year of construction 1963. The tail sheet metal fits for the original AXO lights!



Art.No.	Quality	needed qty
48350	3	1



Citroën HY Pick Up 1963 >
Tail sheet metal on the right. Suitable for Citroën HY Pick UP, starting from year of construction 1963. The tail sheet metal is without lamp bores for tail lamps.



Art.No.	Quality	needed qty
48352	3	1



Cross-beam under the roof in the box body. Suitable for Citroën HY. Or.Nr. H825-84.



Art.No.	Quality	needed qty
48259	3	3



Floor, pre-assembled, enabling to extend the box body about 63 cm, for Citroën HY. Citroën never produced long version HY. All extended HY vehicles have been modified by body shops. This complete floor is the basis for an HY extension of 63 cm.



Art.No.	Quality	needed qty
48256	3	1



Citroën HY Pick Up
License plate fixture Citroën HY Pick UP. Also universal usable. E.G. Peugeot 203 Pick UP.



Art.No.	Quality	needed qty
44906	3	1

0702 rear body components

1
2
3
4
5
6
7
8
9
10
11
12
13
14

Citroën HY Pick Up



License plate fixture Citroën HY Pick UP. Also universal usable. E.G. Peugeot 203 Pick UP. For license plate measurement: 200 x 330mm

Art.No.	Quality	needed qty
48364	3	1



Rear wall above for cab. Suitable for Citroën HY Pick UP. Or. No. HP823-7.

Art.No.	Quality	needed qty
48253	3	1



Rear wall bottom for cab. Suitable for Citroën HY Pick UP. Or. No. HP823-7A.

Art.No.	Quality	needed qty
48254	3	1

Citroën HY



Sliding door rail (horizontal). Suitable for Citroën HY. This rail is like the original, it can be only mounted, if the roof is removed.

Art.No.	Quality	needed qty
48261	3	1

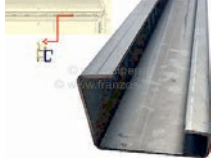

Sliding door rail repair sheet metal (horizontal). Suitable for Citroën HY. This rail do not corresponds to the original, but it can be welded, without dismantling the roof. Length 1480mm.

Art.No.	Quality	needed qty
48267	3	1

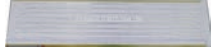

Side panel long, from GRP (synthetic). Suitable for Citroën HY. Length: 1760mm. High: 470mm. Optically like a sheet metal, with cross-beams (axial), above and down. It can be used for on the left (HY821-84) or on the right (HY821-84A). Expansive shipping cost!

Art.No.	Quality	needed qty
48324	3	1



Front wall above the cab roof for raised box bodies, suitable for Citroën HY. If the HY body was raised (by the companies Currus + Heuliez) this sheet metal was welded in the front. (Consisting of 2 sheets, 1x inside, 1x outside)

Art.No.	Quality	needed qty
48255	3	1

Citroën HY > 1963



Bumper bows rear: Mounting reinforcing plate (at the rear crossbeam). Suitable for Citroën HY, to year of construction 1963.

Art.No.	Quality	needed qty
48379	3	2

Citroën HY



Corrugated sheet - side plate on the left completely (consisting of 2 sheet metals 149cm). Suitable for Citroën HY with normal (short) wheel base. The sheet metals have an offset edge, so that they can be added together.

Art.No.	Quality	needed qty
44915	3	1



Side plate with flanges. Flanges length: about 1640mm. Sheet metal length: about 1850mm. Suitable for Citroën HY. The sheet metal has centrally a pressed recess for the mounting of a reinforcement cross-beam. A dispatch is possible only by shipping company. In the case of delivery outside of the European Union, the sheet metal must be cut through by us!

Art.No.	Quality	needed qty
48309	3	1

Citroën HY



Side plate on the right with flanges. Suitable for Citroën HY. Flanges length: about 1640mm. Sheet metal length: about 1850mm. The sheet metal has a pressed recess (joggle) at an end, for the mounting (welding) of a further sheet plate (long sheet metal for extended HY's). The combination of our No. 48303 + 48304 results the long sheet metal for the left side. A dispatch is possible only by shipping company. In the case of delivery outside of the European Union, the sheet metal must be cut by us!

Art.No.	Quality	needed qty
48303	3	1



Side plate on the right, with flanges. Flanges length: about 1640mm. Sheet metal length: about 1850mm. Suitable for Citroën HY standard length, for on the right of side. The sheet metal does not have pressed recess for the mounting of a reinforcement cross-beam. A dispatch is possible only by shipping company. In the case of delivery outside of the European Union, the sheet metal must be cut by us!

Art.No.	Quality	needed qty
48304	3	1

Citroën HY



Corrugated sheet metal - side sheet metal, for the rear extension. This plate gives an extension of approx. 79 cm. The corrugations run out to the rear. The corrugations are cut at the front, so that it can be visually attached directly to the existing corrugations. Suitable for Citroën HY. Per piece.

Art.No.	Quality	needed qty
44929	3	1



Citroën HY
Spring for the hook of the floor panel, in the driver's cab. Suitable for Citroën HY. Or. No. H744-104



Art.No.	Quality	needed qty
48381	3	11



Citroën HY
Floor panel, driver's cab: Screw for the hook of the floor panel, in the driver's cab. Suitable for Citroën HY. Or. No. H744-105



Art.No.	Quality	needed qty
48391	3	11



Citroën HY
Floor pan repair sheet metal in the casing body, over-half cross-beam. Suitable for Citroën HY. Dimension: 120 x 900mm.



Art.No.	Quality	needed qty
48497	3	1



Citroën HY
Floor pan repair sheet metal in the casing body. Suitable for Citroën HY. Dimension: 1000 x 900mm, (two panels of 450x1000mm).



Art.No.	Quality	needed qty
44896	3	1



Citroën HY
Front left wheel arch, cab. Suitable for Citroën HY. This is the wheel arch in the cab. The passenger seat is attached to the wheel arch. Or. no. HY741-71A



Art.No.	Quality	needed qty
48406	3	1



Citroën HY
Front right wheel arch, cab. Suitable for Citroën HY. This is the wheel arch in the cab. The passenger seat is attached to the wheel arch. Or. no. HY741-61



NEW!

Art.No.	Quality	needed qty
48405	3	1



0704 welded body components

1
2
3
4
5
6
7
8
9
10
11
12
13
14



Covering section, for a-post. Suitable for Citroën HY. Length: 1200mm.

Art.No.	Quality	needed qty
48305	3	2

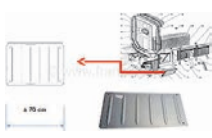

External sheet metal for the reinforcement hollow space on the left + on the right behind the driver's cabin. Suitable for Citroën HY. Or.Nr. H744-118

Art.No.	Quality	needed qty
48269	3	2



Outer hinge strip (Female) Citroën HY. For the bonnet, side flaps, rear flap. 145cm lengthens. Accurate reproduction of the original hinge strip. This part of the hinge is welded at the body. The hinges are manufactured in complex manual work in the European Union.

Art.No.	Quality	needed qty
48283	4	1



Outer hinge strip (Female) Citroën HY. For the bonnet, doors, side flaps, rear flap. 145cm lengthens. Accurate reproduction of the original hinge strip, with extended welding sheet metal (for strong rust damage). This part of the hinge is welded at the body. The hinges are manufactured in complex manual work in the European Union.

Art.No.	Quality	needed qty
48284	4	1



Outer hinge strip (Female) Citroën HY. Particularly produced for the bonnet. The hinge is pushed and welded from downside onto the body edge. Thus results a substantially better stability. This part of the hinge is welded at the body. The hinges are manufactured in complex manual work in the European Union. Length: 145cm.

Art.No.	Quality	needed qty
48285	4	1



Outer hinge strip (Female), for fie French front doors (Suicide door). Suitable for Citroën HY. Particularly produced, in order to mount better the French doors. This part of the hinge is welded at the body. The hinges are manufactured in complex manual work in the European Union. Length: 145cm.

Art.No.	Quality	needed qty
48286	4	2



B-pillar left. Fits Citroën HY, with normal door (HY Benelux version). Very good reproduction from Europe (with all internal reinforcements, without seat belt attachment point). Or. No. 7H 5465 752Y

Art.No.	Quality	needed qty
48394	3	1



B-pillar left. Fits Citroën HY, with suicide door (HY french version). Very good reproduction from Europe (with all internal reinforcements, without seat belt attachment point). Or. No. HP741-116

Art.No.	Quality	needed qty
48392	3	1



B-pillar right. Fits Citroën HY, with normal door (HY Benelux version). Very good reproduction from Europe (with all internal reinforcements, without seat belt attachment point). Or. No. 7H 5465 753J

Art.No.	Quality	needed qty
48395	3	1



B-pillar right. Fits Citroën HY, with suicide door (HY french version). Very good reproduction from Europe (with all internal reinforcements, without seat belt attachment point). Or. No. HP741-116A

Art.No.	Quality	needed qty
48393	3	1



B-pillar reinforcement, for the attachment of a seat belt (anchor point at the top). Suitable for the B-pillar left + right. For Citroën HY with suicide door and normal door. Per piece.

Art.No.	Quality	needed qty
48396	3	1



Sheet metal horizontally, on the left in the reinforcement cross-beam behind the driver's cab. Or. No. HP821-90

Art.No.	Quality	needed qty
44872	3	1



Sheet metal horizontally, on the right in the reinforcement cross-beam behind the driver's cab. Or. No. HP821-90A

Art.No.	Quality	needed qty
44873	3	1



Entrance cross-beam on the left (under the door). Suitable for Citroën HY. Reproduction in manual work. Made one in European Union.

Art.No.	Quality	needed qty
48196	3	1



Entrance cross-beam on the right (under the door). Suitable for Citroën HY. Reproduction in manual work. Made one in European Union.

Art.No.	Quality	needed qty
48197	3	1



0704 welded body components

0 = New old stock
1 = Good
2 = Original
3 = Advanced replica
4 = Replica
5 = Mediocre replica

welded body components 0704



Citroën HY

Driver's cabin HY, reinforcement plate down crosswise. Transition driver's cabin to loading space. Suitable for Citroën HY. Or. No. H741-2



Art.No.	Quality	needed qty
48366	3	1



Citroën HY

Cab HY, reinforcement plate below crosswise: connection plate left. Transition from cab to load compartment. Suitable for Citroën HY.



Art.No.	Quality	needed qty
48382	3	1



Citroën HY

Cab HY, reinforcement plate below crosswise: connection plate right. Transition from cab to load compartment. Suitable for Citroën HY.



Art.No.	Quality	needed qty
48383	3	1



Citroën HY

Cross-beam horizontal at the box body. With bending to incement the side plates. 1500mm lengthens. Suitable for Citroën HY.



Art.No.	Quality	needed qty
48268	3	2



Citroën HY

Cross-beam repair plate for the horizontal cross-beam on the box body. The plate is fitted in the defective cross-beam or as a transition if 2 cross-beams are to be joined together. Suitable for Citroën HY. Length: 1000mm



Art.No.	Quality	needed qty
48388	3	1



Citroën HY

Cross-beam repair plate for the horizontal cross-beam on the box body. The plate is welded over the defective cross-beam (cover). Suitable for Citroën HY. Length: 1000mm



Art.No.	Quality	needed qty
48389	3	1



Citroën HY

Interior hinge strip (Male) Citroën HY. The hinge has a longer welding sheet metal. For the bonnet, doors, side flaps, rear flap. 145cm lengthens. Accurate reproduction of the original hinge strip. This part of the hinge is welded at doors, hood and the bonnet. The hinges are manufactured in complex manual work in the European Union.



Art.No.	Quality	needed qty
48288	4	1



Citroën HY

Interior hinge strip (Male) Citroën HY. The hinge is down additionally curved around 180°. For the bonnet (a reinforcement results) and the rear, lower doors. 145cm lengthens. Accurate reproduction of the original hinge strip. This part of the hinge is welded at doors and the bonnet. The hinges are manufactured in complex manual work in the European Union.



Art.No.	Quality	needed qty
48289	4	1



Citroën HY

Interior hinge strip (Male) Citroën HY. For the bonnet, doors, side flaps, rear flap. 145cm lengthens. Reproduction of the original hinge strip. This part of the hinge is welded at flaps and the bonnet. For the doors this hinge is body-laterally welded. The hinges are manufactured in complex manual work in the European Union.



Art.No.	Quality	needed qty
48287	4	1



Citroën HY

Interior hinge strip (Male) Citroën HY. Particularly produced for the rear doors, if the side panels were exchanged. The hinge has an additional bending. Thus a repair is substantially simpler. Length: 145cm.



Art.No.	Quality	needed qty
48290	4	1



Citroën HY

Fender Triangle sheet metal, in front on the left (transition fender to the driver's cabin). Suitable for Citroën HY.



Art.No.	Quality	needed qty
48170	3	1



Citroën HY

Fender Triangle sheet metal, in front on the right (transition fender to the driver's cabin). Suitable for Citroën HY.



Art.No.	Quality	needed qty
48171	3	1



M5

M5 weld nut (spot weld nut), like original! Suitable for Citroën 2CV, DS, HY



Art.No.	Quality	needed qty
21081	3	1



M7

M7 weld nut (spot weld nut), like original! Suitable for Citroën 2CV, DS, HY



Art.No.	Quality	needed qty
21080	3	1



7x50

M7, washer, diameter 50mm. For the securement of the body on the tank bow. Suitable for Citroën 2CV. Made in Germany.



Art.No.	Quality	needed qty
20140	2	2

- 1
- 2
- 3
- 4
- 5
- 6
- 7
- 8
- 9
- 10
- 11
- 12
- 13
- 14

0704 welded body components

1
2
3
4
5
6
7
8
9
10
11
12
13
14

Citroën HY



Sheet metal down in the wheel housing, on the left (oblique de poutre centrale). Suitable for Citroën HY. Or. No. H741-110

Art.No.	Quality	needed qty
44870	3	1



Citroën HY



Wheel housing on the left: Web (vertical) plate in front in the wheel housing, before the spare wheel! The sheet metal has a "dent". Or. No. H821-93

Art.No.	Quality	needed qty
48365	3	1



Citroën HY



Sheet metal down in the wheel housing, on the right (oblique de poutre centrale). Suitable for Citroën HY. Or. No. H741-110A

Art.No.	Quality	needed qty
44871	3	1



Citroën HY



Front left wheel arch, cab. Suitable for Citroën HY. This is the wheel arch in the cab. The passenger seat is attached to the wheel arch. Or. no. HY741-71A

Art.No.	Quality	needed qty
48406	3	1



Citroën HY



Front right wheel arch, cab. Suitable for Citroën HY. This is the wheel arch in the cab. The passenger seat is attached to the wheel arch. Or. no. HY741-61

Art.No.	Quality	needed qty
48405	3	1



NEW!



Wheel house (on the left) sheet metal centrally, without opening. Suitable for Citroën HY. Or. No. HY821-94A

Art.No.	Quality	needed qty
44849	3	1



Citroën HY



Wheel house (on the left) sheet metal centrally, with opening. Suitable for Citroën HY. Or. No. HY821-94

Art.No.	Quality	needed qty
44848	3	1



Citroën HY



Wheel house front panel sheet metal on the left. Suitable for Citroën HY. Or. No. H821-93

Art.No.	Quality	needed qty
44846	3	1



Citroën HY



Wheel house front panel sheet metal on the right + centric sheet metal in the right wheel house. Suitable for Citroën HY. Or. No. H821-93A

Art.No.	Quality	needed qty
44847	3	2



Citroën HY



Repair sheet metal, for the side plate in front on the left (headlight mounting). Suitable for Citroën HY.

Art.No.	Quality	needed qty
48166	3	1



Citroën HY



Repair sheet metal, for the side plate in front on the right (headlight mounting). Suitable for Citroën HY.

Art.No.	Quality	needed qty
48167	3	1



Citroën HY



Sliding door rubber stop bar (profile sheet metal, triangular). Suitable for Citroën HY. Vertically, welds behind the sliding door. Or. No. H812-77

Art.No.	Quality	needed qty
48354	3	1



Citroën HY



Side plate securement sheet metal on the left (knob on the left). Suitable for Citroën HY. Or. No. H814-68

Art.No.	Quality	needed qty
44893	3	1



Citroën HY



Side plate securement sheet metal on the right (knob on the right). Suitable for Citroën HY. Or. No. H814-68A

Art.No.	Quality	needed qty
44894	3	1



Citroën HY



Side plate reinforcement (centric from the rear) on the left (knob on the left). Suitable for Citroën HY.

Art.No.	Quality	needed qty
44904	3	1



Citroën HY



Side plate reinforcement (centric from the rear) on the right (knob on the left). Suitable for Citroën HY.

Art.No.	Quality	needed qty
44905	3	1



Citroën HY



Side plate complete, in front on the left. Made by "Der Franzose". The sheet metal is a after-production with all reinforcement, like original. Very high quality. Or. No. H82271

Art.No.	Quality	needed qty
48098	3	1



welded body components 0704



Citroën HY

Side plate complete, in front on the right. Made by "Der Franzose". The sheet metal is a after-production with all reinforcement, like original. Very high quality. Or. No. H82271A

Art.No.	Quality	needed qty
48099	3	1





Side plate on the left, between the step and the door. Suitable for Citroën HY. Reproduction in manual work. Made one in European Union.

Art.No.	Quality	needed qty
48202	3	1





Side plate on the right, between the step and the door. Suitable for Citroën HY. Reproduction in manual work. Made one in European Union.

Art.No.	Quality	needed qty
48203	3	1

Step on the left, above closed. Suitable for Citroën HY. Reproduction in manual work. Made one in European Union.

Art.No.	Quality	needed qty
48198	3	1



Step on the right, above closed. Suitable for Citroën HY. Reproduction in manual work. Made one in European Union.



Art.No.	Quality	needed qty
48199	3	1

Citroën HY

Jacking support in the rear (per piece, on the left of or on the right suitable). Suitable for Citroën HY. Or. No. HY623-89



Art.No.	Quality	needed qty
44914	3	2

Citroën HY



Jacking support in front (per piece, on the left of or on the right suitable). Suitable for Citroën HY. Or. No. HY623-85

Art.No.	Quality	needed qty
44913	3	2



Jacking point sheet metal at the rear left. Suitable for Citroën HY

Art.No.	Quality	needed qty
44854	3	1



Jacking point sheet metal rear on the right. Suitable for Citroën HY.

Art.No.	Quality	needed qty
44855	3	1



Jacking point sheet metal in front on the left. Suitable for Citroën HY. Or. No. H741-83

Art.No.	Quality	needed qty
44852	3	1

Jacking point sheet metal in front on the right. Suitable for Citroën HY. Or. No. H741-83A

Art.No.	Quality	needed qty
44853	3	1

Citroën HY

Corrugated sheet - side plate on the left completely (consisting of 2 sheet metals 149cm). Suitable for Citroën HY with normal (short) wheel base. The sheet metals have an offset edge, so that they can be added together.

Art.No.	Quality	needed qty
44915	3	1



Side plate with flanges. Flanges length: about 1640mm. Sheet metal length: about 1850mm. Suitable for Citroën HY. The sheet metal has centrally a pressed recess for the mounting of a reinforcement cross-beam. A dispatch is possible only by shipping company. In the case of delivery outside of the European Union, the sheet metal must be cut through by us!

Art.No.	Quality	needed qty
48309	3	1



Side plate on the right with flanges. Suitable for Citroën HY. Flanges length: about 1640mm. Sheet metal length: about 1850mm. The sheet metal has a pressed recess (joggle) at an end, for the mounting (welding) of a further sheet plate (long sheet metal for extended HY's). The combination of our No. 48303 + 48304 results the long sheet metal for the left side. A dispatch is possible only by shipping company. In the case of delivery outside of the European Union, the sheet metal must be cut by us!

Art.No.	Quality	needed qty
48303	3	1



- 1
- 2
- 3
- 4
- 5
- 6
- 7
- 8
- 9
- 10
- 11
- 12
- 13
- 14

0704 welded body components

1



Side plate on the right, with flanges. Flanges length: about 1640mm. Sheet metal length: about 1850mm. Suitable for Citroën HY standard length, for on the right of side. The sheet metal does not have pressed recess for the mounting of a reinforcement cross-beam. A dispatch is possible only by shipping company. In the case of delivery outside of the European Union, the sheet metal must be cut by us!



Art.No.	Quality	needed qty
48304	3	1

2

Citroën HY



Corrugated sheet repair sheet metal, largely. Suitable for Citroën HY. 12 flanges. Measurements: 600 x 1000mm. Accurate copy of the original flanges!



Art.No.	Quality	needed qty
48222	3	1

3

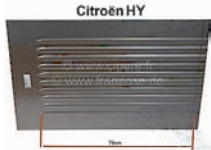

Corrugated sheet metal - side sheet metal, for the rear extension. This plate gives an extension of approx. 79 cm. The corrugations run out to the rear. The corrugations are cut at the front, so that it can be visually attached directly to the existing corrugations. Suitable for Citroën HY. Per piece.



Art.No.	Quality	needed qty
44929	3	1

4

Citroën HY



Corrugated sheet, repair panel, small. Suitable for Citroën HY. 10 flanges. Measurements: 460 x 660mm.



Art.No.	Quality	needed qty
48221	3	1

5

DerFranzose
 Citroën Peugeot Renault
 www.franzose.com

6

7

8

9

10

11

12

13

14



doors front + rear + attachments 0705

Citroën 2CV



2CV/HY, Door brake, pin for the securement of the door brake. Diameter 5,9mm, pin length 34mm. Suitable for Citroën 2CV + HY. Made by Franzose / CiPeRe



Art.No.	Quality	needed qty
16118	3	2



Covering section, for a-post. Suitable for Citroën HY. Length: 1200mm.



Art.No.	Quality	needed qty
48305	3	2

Citroën AK
AZU, ACDY, HY



AK400/ACDY/AZU/HY, spring for the locking pin of the tail gates. Or.Nr.H8623



Art.No.	Quality	needed qty
15460	4	2

AK, AZU, ACDY, HY



AK400/ACDY/AZU/HY, locking pin tail gate. Or. No. H8632



Art.No.	Quality	needed qty
15462	4	2



D: 20mm

Stop rubber mushroom, suitable for Citroën 11CV + universal. Diameter: 20mm. Overall height: 19mm. Or. No. 233400



Art.No.	Quality	needed qty
60297	3	25

Citroën HY



Outer hinge strip (Female) Citroën HY. For the bonnet, side flaps, rear flap. 145cm lengthens. Accurate reproduction of the original hinge strip. This part of the hinge is welded at the body. The hinges are manufactured in complex manual work in the European Union.



Art.No.	Quality	needed qty
48283	4	1

Citroën HY



Outer hinge strip (Female) Citroën HY. For the bonnet, doors, side flaps, rear flap. 145cm lengthens. Accurate reproduction of the original hinge strip, with extended welding sheet metal (for strong rust damage). This part of the hinge is welded at the body. The hinges are manufactured in complex manual work in the European Union.



Art.No.	Quality	needed qty
48284	4	1

Citroën HY



Outer hinge strip (Female), for fie French front doors (Suicide door). Suitable for Citroën HY. Particularly produced, in order to mount better the French doors. This part of the hinge is welded at the body. The hinges are manufactured in complex manual work in the European Union. Length: 145cm.



Art.No.	Quality	needed qty
48286	4	2

Citroën HY



Window frame (sliding window), for the front door. Per piece. Suitable for Citroën HY, starting from year of construction 3/1967. Or. No. HY96181



Art.No.	Quality	needed qty
48089	3	2



Rubber seal profile (by meters), for nearly all older Citroën, 2CV, HY, DS. (Door + luggage compartment seals)! Made in Germany! Quality: EPDM 317. Easily rubbed in with talcum powder. Wide one: 25,5mm



Art.No.	Quality	needed qty
16326	3	

Citroën HY



Interior hinge strip (Male) Citroën HY. The hinge has a longer welding sheet metal. For the bonnet, doors, side flaps, rear flap. 145cm lengthens. Accurate reproduction of the original hinge strip. This part of the hinge is welded at doors, hood and the bonnet. The hinges are manufactured in complex manual work in the European Union.



Art.No.	Quality	needed qty
48288	4	1

Citroën HY



Interior hinge strip (Male) Citroën HY. For the bonnet, doors, side flaps, rear flap. 145cm lengthens. Reproduction of the original hinge strip. This part of the hinge is welded at flaps and the bonnet. For the doors this hinge is body-laterally welded. The hinges are manufactured in complex manual work in the European Union.



Art.No.	Quality	needed qty
48287	4	1

M7x12



M7x12. Countersunk screw 7mm, with flat bolt head! Material: High-grade steel. The bolt head has about 12mm diameter! E.G. suitable for the door lock wedges (Citroën 11CV).



Art.No.	Quality	needed qty
60575	1	24

M7 x 20



Countersunk screw M7x20, e.g. door hinges Citroën 11CV/15CV



Art.No.	Quality	needed qty
60341	3	24

- 1
- 2
- 3
- 4
- 5
- 6
- 7
- 8
- 9
- 10
- 11
- 12
- 13
- 14



0705 doors front + rear + attachments

1
2
3
4
5
6
7
8
9
10
11
12
13
14





Glue for rubber. 70ml.

Art.No.	Quality	needed qty
20493	3	1

Sliding door Citroën HY, only outer skin. Reproduction from GRP (synthetic). Made one in European Union

Art.No.	Quality	needed qty
48271	4	1



Citroën HY Sliding door rubber stop bar (profile sheet metal, triangular). Suitable for Citroën HY. Vertically, welds behind the sliding door. Or. No. H812-77

Art.No.	Quality	needed qty
48354	3	1





Citroën HY Sliding door complete (made of GRP with metal frame). Suitable for Citroën HY (normal height). Made in EU

Art.No.	Quality	needed qty
48399	4	1

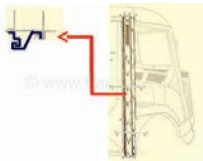

Citroën HY Sliding door complete, for raised roof (made of GRP with metal frame). Suitable for Citroën HY. Made in EU

Art.No.	Quality	needed qty
48400	4	1



Sliding door profile in front (stop sliding door). Length: 50cm. Suitable for Citroën HY.

Art.No.	Quality	needed qty
48348	3	1



gauche left links Safety sheet suicide door on the left down. Suitable for Citroën HY. Or. No. HY841-59

Art.No.	Quality	needed qty
48298	3	1



droite right rechts Safety sheet suicide door on the right down. Suitable for Citroën HY. Or. No. HY841-59A

Art.No.	Quality	needed qty
48299	3	1

Citroën HY Mirror bracket reinforcement at the top of the door. This bracket fits at the top of the door, and is mounted above the bead. Suitable for Citroën HY.

Art.No.	Quality	needed qty
48390	3	2

Citroën HY Mirror with securing clip, without fixture arm. Suitable for Citroën HY, to year of construction 1971. Made in France

Art.No.	Quality	needed qty
47000	2	2





Citroën HY Door seal in front on the left (normal door). Suitable for Citroën HY. The seal is completely manufactured in Germany. All corners are vulcanized. Made one in Germany. Or. No. HY841-68

Art.No.	Quality	needed qty
44838	2	1

Citroën HY Door seal in front on the left (suicide door). Suitable for Citroën HY. The seal is completely manufactured in Germany. All corners are vulcanized. Made one in Germany. Or. No. H841-68

Art.No.	Quality	needed qty
44836	2	1





Citroën HY Door seal in front on the right (normal door). Suitable for Citroën HY. The seal is completely manufactured in Germany. All corners are vulcanized. Made one in Germany. Or. No. HY841-68A

Art.No.	Quality	needed qty
44839	2	1

Citroën HY Door seal in front on the right (suicide door). Suitable for Citroën HY. The seal is completely manufactured in Germany. All corners are vulcanized. Made one in Germany. Or. No. H841-68A

Art.No.	Quality	needed qty
44837	2	1

Citroën HY Door check strap in front. Suitable for Citroën HY. Length from securement to securement: about 110mm. Height: about 25,5mm. Bore: 6,5mm. Or. No. H84170

Art.No.	Quality	needed qty
48102	4	2



luggage compartment lid + attachments, rear doors 0706

2CV, Luggage compartment hood. Emblem "CITROËN" swung, from 3mm high-grade steel. Made in Germany by Franzose. The signature is about 180mm long, and 65mm highly. The emblems are fastened with 2x M3 nuts (our article number 20166).



Art.No.	Quality	needed qty
16835	3	1



Made in Germany

Rubber seal profile, more curved. We let produce this profile rubber in Germany. The rubber is more curved in itself and can seal so better (e.g. bonnet, rear flap). Suitable for Citroën HY. By meters. Wide one: about 29,5mm. Note: Do not unse this rubber for the doors!



Art.No.	Quality	needed qty
44835	1	



Stop rubber mushroom, suitable for Citroën 11CV + universal. Diameter: 20mm. Overall height: 19mm. Or. No. 233400



Art.No.	Quality	needed qty
60297	3	25



Rubber rosette (seal) under the door handle + luggage compartment handle. Suitable for Citroën 11CV, 15CV + Citroën HY. Dimension: 60 x 35 x 5mm



Art.No.	Quality	needed qty
60360	3	5



Citroën HY

Outer hinge strip (Female) Citroën HY. For the bonnet, side flaps, rear flap. 145cm lengthens. Accurate reproduction of the original hinge strip. This part of the hinge is welded at the body. The hinges are manufactured in complex manual work in the European Union.



Art.No.	Quality	needed qty
48283	4	1



Citroën HY

Outer hinge strip (Female) Citroën HY. For the bonnet, doors, side flaps, rear flap. 145cm lengthens. Accurate reproduction of the original hinge strip, with extended welding sheet metal (for strong rust damage). This part of the hinge is welded at the body. The hinges are manufactured in complex manual work in the European Union.



Art.No.	Quality	needed qty
48284	4	1



Citroën angle (emblem), gold-colored. Reproduction made of metal. Or. No. D854-4



Art.No.	Quality	needed qty
37265	3	1

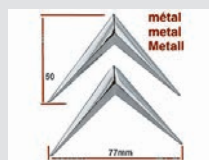

métal
metal
Metall

Citroën angle chromium-plates, made of metal. Universal fitting. 2x brackets = 1x 16807!!
Reproduction



Art.No.	Quality	needed qty
16807	3	1



Made in Germany

Rubber seal profile (by meters), for nearly all older Citroën, 2CV, HY, DS. (Door + luggage compartment seals)! Made in Germany! Quality: EPDM 317. Easily rubbed in with talcum powder. Wide one: 25,5mm



Art.No.	Quality	needed qty
16326	3	



Fixture on the left (at the body) for the door clamp of the lower tail gate. Suitable for Citroën HY. Or. No. H844-105



Art.No.	Quality	needed qty
44850	3	1



Fixture on the right (at the body) for the door clamp of the lower tail gate. Suitable for Citroën HY. Or. No. H844-105A



Art.No.	Quality	needed qty
44851	3	1

Citroën DS



1x

Retaining clip for the seal from the luggage compartment lid. Suitable for Citroën 11CV/15CV. Citroën DS. Dimension: 10 x 14mm. Also suitable for other French vehicles. Or. No. 802698, DM453-120C



Art.No.	Quality	needed qty
60300	3	10



Rear flap above Citroën HY. Reproduction from GRP (synthetic) and metal, with metal hinge! Made in European Union.



Art.No.	Quality	needed qty
48242	3	1



Rear flap above Citroën HY (small rear window). Reproduction from GRP (synthetic) and metal, also in laminated metal hinge! Made one in European Union.



Art.No.	Quality	needed qty
48264	3	1

0706 luggage compartment lid + attachments, rear doors

1
2
3
4
5
6
7
8
9
10
11
12
13
14

Citroën HY



Tailgate handle, suitable for Citroën HY. Or. No. H8638



Art.No.	Quality	needed qty
48103	3	1

remaining stock! while stocks last!



Rear flap above Citroën HY, only outer skin with big window. Reproduction from GRP (synthetic). Made one in European Union



Art.No.	Quality	needed qty
48313	4	1



Rear flap above Citroën HY, only outer skin with small window. Reproduction from GRP (synthetic). Made one in European Union



Art.No.	Quality	needed qty
48270	4	1

Citroën HY



Interior hinge strip (Male) Citroën HY. The hinge has a longer welding sheet metal. For the bonnet, doors, side flaps, rear flap. 145cm lengthens. Accurate reproduction of the original hinge strip. This part of the hinge is welded at doors, hood and the bonnet. The hinges are manufactured in complex manual work in the European Union.



Art.No.	Quality	needed qty
48288	4	1

Citroën HY



Interior hinge strip (Male) Citroën HY. The hinge is down additionally curved around 180°. For the bonnet (a reinforcement results) and the rear, lower doors. 145cm lengthens. Accurate reproduction of the original hinge strip. This part of the hinge is welded at doors and the bonnet. The hinges are manufactured in complex manual work in the European Union.



Art.No.	Quality	needed qty
48289	4	1

Citroën HY



Interior hinge strip (Male) Citroën HY. For the bonnet, doors, side flaps, rear flap. 145cm lengthens. Reproduction of the original hinge strip. This part of the hinge is welded at flaps and the bonnet. For the doors this hinge is body-laterally welded. The hinges are manufactured in complex manual work in the European Union.



Art.No.	Quality	needed qty
48287	4	1

Citroën HY



Interior hinge strip (Male) Citroën HY. Particularly produced for the rear doors, if the side panels were exchanged. The hinge has an additional bending. Thus a repair is substantially simpler. Length: 145cm.



Art.No.	Quality	needed qty
48290	4	1

Citroën HY Pick Up



License plate fixture Citroën HY Pick UP. Also universal usable. E.G. Peugeot 203 Pick UP.



Art.No.	Quality	needed qty
44906	3	1

Citroën HY Pick Up



License plate fixture Citroën HY Pick UP. Also universal usable. E.G. Peugeot 203 Pick UP. For license plate measurement: 200 x 330mm



Art.No.	Quality	needed qty
48364	3	1



Glue for rubber. 70ml.



Art.No.	Quality	needed qty
20493	3	1

Citroën HY



Spare wheel flap (panel), made of metal. Suitable for Citroën HY. Accurate reproduction.



Art.No.	Quality	needed qty
48219	3	1

Citroën HY



Spare wheel flap, suitable for Citroën HY. Reproduction from GRP (synthetic) and metal fixtures. Made one in European Union.



Art.No.	Quality	needed qty
44899	3	1



Sliding door guide bow (the clip leads the sliding door in the rails). Suitable for Citroën HY. Or. No. H842-80. Per piece. Made in Germany.



Art.No.	Quality	needed qty
44828	3	6



Sliding door repair sheet metal, suitable down + above (external sheet metal). 8 flanges! Suitable for Citroën HY.



Art.No.	Quality	needed qty
48095	4	1



Rail down (pre-mounted), at the sliding door. Suitable for Citroën HY.



Art.No.	Quality	needed qty
48294	3	1

luggage compartment lid + attachments, rear doors 0706

1
2
3
4
5
6
7
8
9
10
11
12
13
14



Citroën DS > 1971
Citroën HY 1968 >

Striker plate underlay. Special coarse seal, so that the striker plate cannot slip (anti-slide). Suitable for Citroën DS, to year of construction 1971. Citroën HY, starting from year of construction 1968.



Art.No.	Quality	needed qty
37858	3	4

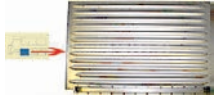

Side plate on the left (corrugated sheet), behind the driver's cabin (before the spare wheel flap). Suitable for Citroën HY. Completely with lower cross-beam. Length: about 92cm. Height: 59cm. Made one in European Union, Top quality! Or. No. H821-97



Art.No.	Quality	needed qty
48227	3	1



Side plate on the left, behind the driver's cabin. Suitable for Citroën HY. Length: about 92cm. Height: about 59,0cm. Produced from GRP. (very good reproduction, you can see the spotwelds!)



Art.No.	Quality	needed qty
48230	3	1



Side flap, from synthetic. Suitable for Citroën HY with long body and Pick UP. Under cross bar is interiorlateral. HY with short wheel base, do not have this flap. Good reproduction with metal frame and synthetic.



Art.No.	Quality	needed qty
48315	3	1



Side flap (panel), made of metal. Suitable for Citroën HY with long body and Pick UP. Under cross bar is interiorlateral. HY with short wheel base, do not have this flap. Accurate reproduction made of metal.



Art.No.	Quality	needed qty
48220	3	1



Safety sheet on the left (centrally in the hinge). For Citroën HY, bonnet and the tail gate. For AZU: Tail gate on the left. Or. No. H844-93



Art.No.	Quality	needed qty
48296	3	2



Safety sheet on the right (centrally in the hinge). For Citroën HY, bonnet and the tail gate. For AZU: Tail gate on the right. Or. No. H844-93A



Art.No.	Quality	needed qty
48297	3	2



Fuel filler flap, from GRP. Suitable for Citroën HY (very good reproduction, you can see the spotwelds!)



Art.No.	Quality	needed qty
48229	3	1



Conversion kit for the upper rear flap. Suitable for Citroën HY. This conversion kit contains all parts, in order to convert the flap on gas pressure shock absorbers. Very practically! Caution, the reinforcement cross-beams in the rear flap must be in a perfect condition.



Art.No.	Quality	needed qty
48302	1	1

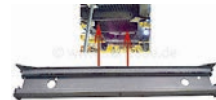

Reinforcement cross-beam, under the body (in front + center). Suitable for Citroën HY. Total width: about 970mm.



Art.No.	Quality	needed qty
48295	3	2



Citroën HY
Corrugated sheet repair sheet metal, largely. Suitable for Citroën HY. 12 flanges. Measurements: 600 x 1000mm. Accurate copy of the original flanges!



Art.No.	Quality	needed qty
48222	3	1



0707 emblems



2CV old, radiator grill, Citroën emblem from aluminum. Suitable for Citroën 2CV to year of construction 1955. (Corrugated sheet bonnet). Very good reproduction. Measurements: 230 x 170mm.



Art.No.	Quality	needed qty
16843	3	1



2CV, Luggage compartment hood. Emblem "CITROËN" swung, from 3mm high-grade steel. Made in Germany by Franzose. The signature is about 180mm long, and 65mm high. The emblems are fastened with 2x M3 nuts (our article number 20166).



Art.No.	Quality	needed qty
16835	3	1



2CV, Luggage compartment hood. Emblem CITROËN made of metal. Reproduction like original, 35x160mm. Also fitting for other Citroën!



Art.No.	Quality	needed qty
16839	3	1



Label "Citroën préfère total" for the back window. Suitable for Citroën DS + 2CV. Dimension: 85 x 110mm.



Art.No.	Quality	needed qty
37070	3	1



Sticker "Citroën Total", in the rear window. For Citroën 2CV, CX, DS, GS. The label is stuck from the inside! Measurements: 32x250mm.



Art.No.	Quality	needed qty
16898	3	1



Label "heuliez" body. Suitable for Citroën HY. 150x50mm



Art.No.	Quality	needed qty
48237	3	2



Label "LHM level", for the LHM reservoir. Dimension: 55 x 85mm.



Art.No.	Quality	needed qty
37312	3	1



Label "LHM". Dimension: 28 x 50mm.



Art.No.	Quality	needed qty
37311	3	1

Citroën HY



Label "air pressure" for tire 17x400. Suitable for Citroën HY.



Art.No.	Quality	needed qty
44884	3	2

Citroën HY



Label "air pressure" for tire 19x400. Suitable for Citroën HY.



Art.No.	Quality	needed qty
44885	3	2



Label "MIOFILTRE" for the air filter. Suitable for Citroën 2CV from the fifties, 11CV, HY.



Art.No.	Quality	needed qty
16906	3	1



Label - emblem "Citroën HY".



Art.No.	Quality	needed qty
44883	3	1



Label for the additional load. Suitable for Citroën HY.



Art.No.	Quality	needed qty
48236	3	2



Label coolant "TOTAL". Dimension: 31 x 62mm.



Art.No.	Quality	needed qty
37313	3	1



Air filter label. Reproduction of the original label (gold colored, red frame). This label was mounted on many air filters. Citroën DS to year of construction 1965, 2CV, HY, Renault, Simca, Peugeot.



Art.No.	Quality	needed qty
32060	3	1

Citroën HY



Label, for the gear shift "Gonflage Speciales". Suitable for Citroën HY.



Art.No.	Quality	needed qty
44888	3	1

Citroën HY



Label, for the gear shift "Pressione Gonflage". Suitable for Citroën HY.



Art.No.	Quality	needed qty
44887	3	1

0707 emblems

0 = New old stock
 1 = Good
 2 = Original
 3 = Advanced replica
 4 = Replica
 5 = Mediocre replica

Citroen HY

Label, for the gear shift (in reverse). Suitable for Citroën HY.

Art.No.	Quality	needed qty
44886	3	1

Citroen HY

Label, for the gear shift at the dashboard. Old version. Suitable for Citroën HY.

Art.No.	Quality	needed qty
44889	3	1

Citroen HY

Label, for the gear shift at the dashboard. New version. Suitable for Citroën HY.

Art.No.	Quality	needed qty
44890	3	1

Citroen HY

Label, for the gear change lever position. Suitable for Citroën HY.

Art.No.	Quality	needed qty
48235	3	1

Citroën 11CV + 15CV

Citroën emblem (Chevron) on the dashboard. Suitable for Citroën 11CV + 15CV, up to year of construction 02/1952. Or. No. 802594. Dimension: 38 x 40mm. The emblem can also be used universal.

Art.No.	Quality	needed qty
60160	3	1

Citroën angle (emblem), gold-colored.

Reproduction made of metal. Or. No. D854-4

Art.No.	Quality	needed qty
37265	3	1

Citroën angle chromium-plates, made of metal.

Universal fitting. 2x brackets = 1x 16807!!
Reproduction

Art.No.	Quality	needed qty
16807	3	1

Emblem "Citroën", as label, gold - black.

Original-faithful reproduction. Measurements: 38x115mm

Art.No.	Quality	needed qty
16893	3	1

2,5mm

Retaining tie-clip for emblems. Suitable for 2,5mm of pins. Per piece.

Art.No.	Quality	needed qty
37719	3	1

2mm

Retaining tie-clip for emblems. Suitable for 2mm of pins. Per piece.

Art.No.	Quality	needed qty
37718	3	1

3mm

Retaining tie-clip for emblems. Suitable for 3mm pins. Per piece!

Art.No.	Quality	needed qty
16861	3	4

4mm

Retaining tie-clip (locking clip), for 4mm pins (securement of emblems). Per piece. Or. No. ZC9619867U

Art.No.	Quality	needed qty
37264	3	1

Dr: 3,8mm

Retaining clip emblems for Citroën, Renault, Peugeot, old models. 2.5mm inner diameter (i.e. for 2.5mm pins on the emblems). Length: 7.5mm. Per piece

Art.No.	Quality	needed qty
77624	3	1

TOTAL

Label engine oil "TOTAL". Dimension: 32 x 65mm.

Art.No.	Quality	needed qty
37310	3	1

ANDRE CITROËN 5th Ath PARIS

Identification plate green, for Citroën. 78x40mm. 2 bores. (Metal). The green identification plates were often used for gearbox identification!

Art.No.	Quality	needed qty
16973	3	1

ANDRE CITROËN 5th Ath PARIS

Identification plate engine, black. Suitable for Citroën, 2CV (old version), 11CV, HY, DS.

Art.No.	Quality	needed qty
17139	3	1

ANDRE CITROËN 5th Ath PARIS

Identification plate orange, for Citroën. 78x40mm. 2 bores. (Metal). The red identification plates were often used for engine numbers!

Art.No.	Quality	needed qty
16972	3	1

S.A.A. CITROËN

Identification plate S.A.A. Citroën. These identification plates are installed in 2CV, DS, 11CV, HY. Measurements of 43x70mm. Unfortunately a bad reproduction.

Art.No.	Quality	needed qty
16932	4	1

1
2
3
4
5
6
7
8
9
10
11
12
13
14

0707 emblems



Identification plate, German version, for Citroën. (Metal). 110x50mm. 4 bores.



Art.No.	Quality	needed qty
16974	3	1

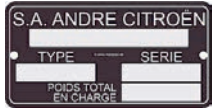

Identification plate, original-faithful reproduction. Suitable for Citroën 2CV, DS, HY, 11CV. Measurements: 43 x 78mm.



Art.No.	Quality	needed qty
16897	3	1



Identification plate, original-faithful reproduction. Suitable for Citroën 2CV. 46x90mm



Art.No.	Quality	needed qty
16916	3	1



www.cipere.fr

www.franzose.de

www.franzose.com



0707 emblems

0 = New old stock
1 = Good
2 = Original

3 = Advanced replica
4 = Replica
5 = Mediocre replica



www.franzose.com



Citroën HY

Fender Triangle sheet metal, in front on the left (transition fender to the driver's cabin). Suitable for Citroën HY.



Art.No.	Quality	needed qty
48170	3	1

Citroën HY

Fender Triangle sheet metal, in front on the right (transition fender to the driver's cabin). Suitable for Citroën HY.



Art.No.	Quality	needed qty
48171	3	1

Citroën HY

Fender in front (1 pair), out of sheet metal. Suitable for Citroën HY. The fenders are manufactured in complex manual work!



Art.No.	Quality	needed qty
48208	3	1

Citroën HY

Fender in front on the left, from synthetic (GRP). Suitable for Citroën HY.



Art.No.	Quality	needed qty
48210	4	1

Citroën HY

Fender in front, on the left (out of metal). Suitable for Citroën HY.



Art.No.	Quality	needed qty
48407	3	1

Citroën HY

Fender in front on the right, from synthetic (GRP). Suitable for Citroën HY.



Art.No.	Quality	needed qty
48211	4	1

Citroën HY

Fender in front, on the right (out of metal). Suitable for Citroën HY.



Art.No.	Quality	needed qty
48408	3	1

Citroën HY

Fender sealing trim, 2 pieces. Suitable for Citroën HY, for the front fenders. Or. No. H851-96A



Art.No.	Quality	needed qty
44864	3	1

Citroën HY

Front left wheel arch, cab. Suitable for Citroën HY. This is the wheel arch in the cab. The passenger seat is attached to the wheel arch. Or. no. HY741-71A



Art.No.	Quality	needed qty
48406	3	1

Citroën HY

Front right wheel arch, cab. Suitable for Citroën HY. This is the wheel arch in the cab. The passenger seat is attached to the wheel arch. Or. no. HY741-61

Art.No.	Quality	needed qty
48405	3	1

Citroën HY

Mudflap right, with stainless steel bracket. Suitable for Citroën HY. Or. No. H851-4D



Art.No.	Quality	needed qty
44927	3	1

Citroën HY

Mudflap right, with stainless steel bracket. Suitable for Citroën HY. Or. No. H851-4D

Art.No.	Quality	needed qty
44928	3	1

Citroën HY

Footboards on the left + on the right, for the entrance (Robri). Suitable for Citroën HY. Produced from polished, aluminum casting.

Art.No.	Quality	needed qty
48291	3	1



- 1
- 2
- 3
- 4
- 5
- 6
- 7
- 8
- 9
- 10
- 11
- 12
- 13
- 14

0709 rear wing

1
2
3
4
5
6
7
8
9
10
11
12
13
14



Fender at the rear left, old design. Suitable for Citroën HY, up to year of construction 11/1969. Very good reproduction made of GRP, with in-laminated stainless steel fixtures!



Art.No.	Quality	needed qty
48325	3	1



Fender rear on the left, made from sheet metal. (angular wheel arch). Suitable for Citroën HY starting from year of construction 1968.



Art.No.	Quality	needed qty
48265	3	1



Fender at the rear left, made from sheet metal. (round wheel arch). Suitable for Citroën HY, up to year of construction 1968.



Art.No.	Quality	needed qty
48355	3	1



Fender at the rear left, new model. Suitable for Citroën HY. Very good reproduction made of GRP, with in-laminated stainless steel fixtures!



Art.No.	Quality	needed qty
48231	3	1



Fender at the rear right, old design. Suitable for Citroën HY, up to year of construction 11/1969. Very good reproduction made of GRP, with in-laminated stainless steel fixtures!



Art.No.	Quality	needed qty
48326	3	1



Fender rear on the right, made from sheet metal. (angular wheel arch). Suitable for Citroën HY starting from year of construction 1968.



Art.No.	Quality	needed qty
48266	3	1



Fender at the rear right, made from sheet metal. (round wheel arch). Suitable for Citroën HY, up to year of construction 1968.



Art.No.	Quality	needed qty
48356	3	1



Fender at the rear right, new model. Suitable for Citroën HY. Very good reproduction made of GRP, with in-laminated stainless steel fixtures!



Art.No.	Quality	needed qty
48232	3	1



Tank filler rubber seal, in the rear right fender. Colour grey. Fits Citroën 2CV from 1967 to 1990, Citroën DS up to 1974, HY from 09/1968, 11CV from 7/1952.



Art.No.	Quality	needed qty
16143	3	1



Tank filler rubber seal, in the rear right fender. Colour black. Fits Citroën 2CV from 1967 to 1990, Citroën DS up to 1974, HY from 09/1968, 11CV from 7/1952.



Art.No.	Quality	needed qty
16087	3	1



Rubber seal for the tank neck. Old version. Color: beige. Citroën 2CV to about year of construction 1967. Citroën AZU. Citroën HY, to year of construction 09/1968.



Art.No.	Quality	needed qty
16493	3	1



Rubber seal for the tank neck. Old version. Color: grey. Citroën 2CV to about year of construction 1967. Citroën AZU. Citroën HY, to year of construction 09/1968.



Art.No.	Quality	needed qty
16407	3	1



Rubber seal for the tank neck. Old version. Color: black. Citroën 2CV to about year of construction 1967. Citroën AZU. Citroën HY, to year of construction 09/1968.



Art.No.	Quality	needed qty
16406	3	1



engine bonnet + front panels + radiator grills 0710

2CV old, radiator grill, Citroën emblem from aluminum. Suitable for Citroën 2CV to year of construction 1955. (Corrugated sheet bonnet). Very good reproduction. Measurements: 230 x 170mm.



Art.No.	Quality	needed qty
16843	3	1



Stop rubber mushroom, suitable for Citroën 11CV + universal. Diameter: 20mm. Overall height: 19mm. Or. No. 233400



Art.No.	Quality	needed qty
60297	3	25



Outer hinge strip (Female) Citroën HY. Particularly produced for the bonnet. The hinge is pushed and welded from downside onto the body edge. Thus results a substantially better stability. This part of the hinge is welded at the body. The hinges are manufactured in complex manual work in the European Union. Length: 145cm.



Art.No.	Quality	needed qty
48285	4	1



Turn signal fixture in front on the left + in front on the right (2 pieces). Suitable for Citroën HY. Or. No. HY575-233A + HY575-234A



Art.No.	Quality	needed qty
44869	3	1



Rubber seal profile, more curved. We let produce this profile rubber in Germany. The rubber is more curved in itself and can seal so better (e.g. bonnet, rear flap). Suitable for Citroën HY. By meters. Wide one: about 29,5mm. Note: Do not use this rubber for the doors!



Art.No.	Quality	needed qty
44835	1	



Interior hinge strip (Male) Citroën HY. The hinge is down additionally curved around 180°. For the bonnet (a reinforcement results) and the rear, lower doors. 145cm lengthens. Accurate reproduction of the original hinge strip. This part of the hinge is welded at doors and the bonnet. The hinges are manufactured in complex manual work in the European Union.



Art.No.	Quality	needed qty
48289	4	1



Ventilation shutter rubber (2 item). Suitable for Citroën HY, starting from year of construction 1964. Or. No. H644-70



Art.No.	Quality	needed qty
44911	3	1



M8 x 25 screws, with 20mm head. The suitable for radiator grill securement to Citroën 11CV. This screw can be also universal used, for example fasten from bumpers. Or. No. 331101



Art.No.	Quality	needed qty
60273	3	4



Bonnet (old model). Suitable for Citroën HY, to year of construction 09/1964. The bonnet is a combination made of GRP and metal. With upper hinge and lower latching. Or. No. HY852-01A



Art.No.	Quality	needed qty
44898	3	1



Bonnet (new model). Suitable for Citroën HY, starting from year of construction 09/1964. The bonnet is a combination made of GRP and metal. With upper hinge and lower latching. Or. No. HY852-01B



Art.No.	Quality	needed qty
44921	3	1



Rubber for engine bonnet lock, 2 pieces



Art.No.	Quality	needed qty
50069	3	



Repair sheet metal, for the side plate in front on the left (headlight mounting). Suitable for Citroën HY.



Art.No.	Quality	needed qty
48166	3	1



Repair sheet metal, for the side plate in front on the right (headlight mounting). Suitable for Citroën HY.



Art.No.	Quality	needed qty
48167	3	1



Side plate securement sheet metal on the left (knob on the left). Suitable for Citroën HY. Or. No. H814-68



Art.No.	Quality	needed qty
44893	3	1



Side plate securement sheet metal on the right (knob on the right). Suitable for Citroën HY. Or. No. H814-68A



Art.No.	Quality	needed qty
44894	3	1

0710 engine bonnet + front panels + radiator grills

0711 body seals

1
2
3
4
5
6
7
8
9
10
11
12
13
14



Citroën HY
Side plate reinforcement (centric from the rear) on the left (knob on the left). Suitable for Citroën HY.



Art.No.	Quality	needed qty
44904	3	1



Citroën HY
Side plate reinforcement (centric from the rear) on the right (knob on the left). Suitable for Citroën HY.



Art.No.	Quality	needed qty
44905	3	1



Citroën HY
Side plate complete, in front on the left. Made by "Der Franzose". The sheet metal is a after-production with all reinforcement, like original. Very high quality. Or. No. H82271



Art.No.	Quality	needed qty
48098	3	1



Citroën HY
Side plate complete, in front on the right. Made by "Der Franzose". The sheet metal is a after-production with all reinforcement, like original. Very high quality. Or. No. H82271A



Art.No.	Quality	needed qty
48099	3	1



gauche
left
links
Safety sheet on the left (centrically in the hinge). For Citroën HY, bonnet and the tail gate. For AZU: Tail gate on the left. Or. No. H844-93



Art.No.	Quality	needed qty
48296	3	2



droite
right
rechts
Safety sheet on the right (centrically in the hinge). For Citroën HY, bonnet and the tail gate. For AZU: Tail gate on the right. Or. No. H844-93A



Art.No.	Quality	needed qty
48297	3	2



Winter protection, for the radiator grill. Citroën HY.



Art.No.	Quality	needed qty
48272	3	1



Rubber seal profile (by meters), for nearly all older Citroën, 2CV, HY, DS. (Door + luggage compartment seals)! Made in Germany! Quality: EPDM 317. Easily rubbed in with talcum powder. Wide one: 25,5mm



Art.No.	Quality	needed qty
16326	3	



Made in Germany
Rubber seal profile, more curved. We let produce this profile rubber in Germany. The rubber is more curved in itself and can seal so better (e.g. bonnet, rear flap). Suitable for Citroën HY. By meters. Wide one: about 29,5mm. Note: Do not unse this rubber for the doors!



Art.No.	Quality	needed qty
44835	1	



Black sealant putty, e.g. for sealing the windscreen of the Citroën DS. Dimensions: width 10mm, height 5mm, length 2500mm. This putty is also ideal for sealing openings in the engine front wall (cable ducts, choke cables, etc.).



Art.No.	Quality	needed qty
35032	2	1

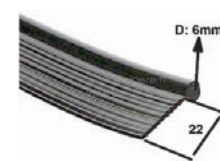

Fender sealing trim in black, universal fitting, by meters. Customer cut, return not possible!



Art.No.	Quality	needed qty
19038	3	



expanding rivet with safety pin. (3,5mm) 100 pieces!



Art.No.	Quality	needed qty
18421	2	



5,5mm
expanding rivet with safety pin. (5,5mm) 30 pieces!



Art.No.	Quality	needed qty
18423	2	



Glue for rubber. 70ml.



Art.No.	Quality	needed qty
20493	3	1



0710 engine bonnet + front panels + radiator grills

0711 body seals

0 = New old stock
1 = Good
2 = Original
3 = Advanced replica
4 = Replica
5 = Mediocre replica

door locks + handles 0712

Citroen 2CV
Mehari, HY

2CV old/Mehari/HY, door lock, lockcylinder set for old 2CV + Mehari, HY. 2x door lock (round pin) + 1x starter lock (angular pin)! With vehicles with starter button!

Art.No.	Quality	needed qty
16187	2	1

End (from rubber), for the tension rod from the door opener (securement at the internal door handle). Suitable for Citroën DS + HY. Or. No. D861-149

Art.No.	Quality	needed qty
37290	3	4

Graphitic oil, lock oil. Optimally to clean and lubricate locks (door lock, starter lock etc.). 50ml.

Art.No.	Quality	needed qty
20927	3	1

Rubber rosette (seal) under the door handle + luggage compartment handle. Suitable for Citroën 11CV, 15CV + Citroën HY. Dimension: 60 x 35 x 5mm

Art.No.	Quality	needed qty
60360	3	5

Sliding door guide bow (the clip leads the sliding door in the rails). Suitable for Citroën HY. Or. No. H842-80. Per piece. Made in Germany.

Art.No.	Quality	needed qty
44828	3	6

Citroën HY

Lock cylinder for the tailgate. Original Citroën, no replica. Or. No. H863 35

Art.No.	Quality	needed qty
48175	2	1

remaining stock!
while stocks last!

Lockcylinder set, suitable for Citroën HY. Consisting of: 2x lockcylinder doors driver's cabin. 1x lockcylinder for starter lock. 1x lockcylinder rear flap.

Art.No.	Quality	needed qty
48274	3	1

Citroen DS >1971 HY 1968>

Striker plate on the left, chrom-plated. Suitable for Citroën DS, up to year of construction 1971 (2x required). Citroën HY, starting from year of construction 1968 (1x required). Or. No. D861-79B

Art.No.	Quality	needed qty
37770	3	2

Citroen DS >1971 HY 1968>

Striker plate on the left. Suitable for Citroën DS, up to year of construction 1971 (2x required). Citroën HY, starting from year of construction 1968 (1x required). Or. No. D861-79B

Art.No.	Quality	needed qty
37752	3	2

Citroen DS >1971 HY 1968>

Striker plate on the right, chrom-plated. Suitable for Citroën DS, up to year of construction 1971 (2x required). Citroën HY, starting from year of construction 1968 (1x required). Or. No. D861-79C

Art.No.	Quality	needed qty
37771	3	2

Citroen DS >1971 HY 1968>

Striker plate on the right. Suitable for Citroën DS, up to year of construction 1971 (2x required). Citroën HY, starting from year of construction 1968 (1x required). Or. No. D861-79C

Art.No.	Quality	needed qty
37753	3	2

Citroen DS, AMI SM, GS, CX...

Blank key door lock. Suitable for Citroën DS, up to year of construction 1974. Citroën AMI6 + AMI8. Citroën SM, CX 2000, GS, VISA. Peugeot J9. Maserati Bora, Indy 4900 America, Merak. For lock manufacturers: RONIS. Shaft length: 17,3mm. Shaft width: 7,0mm. Please observe the cross section of the key bit.

Art.No.	Quality	needed qty
33267	2	1

M7x28

Screw (countersunk head) M7, aluminum, for the striker plate. Suitable for Citroën DS, up to year of construction 1971. Citroën HY, starting from year of construction 1968. Or. No. DX861-92. Per piece

Art.No.	Quality	needed qty
37773	3	8

M7 x 28

Screw (countersunk head) M7, chrom-plated, for the striker plate. Suitable for Citroën DS Pallas, up to year of construction 1971. Citroën HY, starting from year of construction 1968. Or. No. DX861-92A. Per piece

Art.No.	Quality	needed qty
37774	3	8

Citroën DS (Non Pallas) + ID Citroën HY, AMI6

Door handle, inside left. Plastic. Colour: grey. Suitable for Citroën DS (non Pallas), ID. Citroën HY, Citroën AMI6. Lever length: 73mm. Suitable for front and rear. Or. no. DM861-24D. Good reproduction.

Art.No.	Quality	needed qty
38680	3	1

NEW!

- 1
- 2
- 3
- 4
- 5
- 6
- 7
- 8
- 9
- 10
- 11
- 12
- 13

0712 door locks + handles

1
2
3
4
5
6
7
8
9
10
11
12
13
14



NEW!

Door handle, inside left. Plastic. Colour: grey. Suitable for Citroën DS (non Pallas), ID. Citroën HY, Citroën AMI6. Lever length: 79mm. Suitable for front and rear. Or. no. DV861-24. Good reproduction.



Art.No.	Quality	needed qty
38682	3	1



NEW!

Door handle, inside right. Plastic. Colour: black. Suitable for Citroën DS (non Pallas), ID. Citroën HY, Citroën AMI6. Lever length: 73mm. Suitable for front and rear. Or. no. AMF861-24A. Good reproduction.



Art.No.	Quality	needed qty
38679	3	1



NEW!

Door handle, inside left. Plastic. Colour: black. Suitable for Citroën DS (non Pallas), ID. Citroën HY, Citroën AMI6. Lever length: 73mm. Suitable for front and rear. Or. no. AMF861-24. Good reproduction.



Art.No.	Quality	needed qty
38678	3	1



Door handle inside, chrom-plated. Suitable for Citroën 11CV + 15CV. Citroën HY, first version. Square mounting 9.8 - 10,0mm. Overall length: 108mm. Or. No. 132513



Art.No.	Quality	needed qty
60346	3	4



NEW!

Door handle, inside right. Plastic. Colour: grey. Suitable for Citroën DS (non Pallas), ID. Citroën HY, Citroën AMI6. Lever length: 73mm. Suitable for front and rear. Or. no. DM861-24E. Good reproduction.



Art.No.	Quality	needed qty
38681	3	1

Citroen DS + HY



Door handle inside. Rubber seal under the door handle inside. Suitable for Citroën DS, all years of construction + HY. Or. No. D861-74 + DX861-74



Art.No.	Quality	needed qty
38015	3	4



NEW!

Door handle, inside right. Plastic. Colour: grey. Suitable for Citroën DS (non Pallas), ID. Citroën HY, Citroën AMI6. Lever length: 79mm. Suitable for front and rear. Or. no. DV861-24A. Good reproduction.



Art.No.	Quality	needed qty
38683	3	1



remaining stock! while stocks last!

Door handle set (left + right outside + left + right inside), suitable for Citroën HY, up to year of manufacture 4/1978. Beautiful reproduction.



Art.No.	Quality	needed qty
48080	3	1



door pane + attachments 0713



Citroën 2CV
AK, AZU, Dyane, HY
www.derfranzose.de

220cm

Back window seal - sealing trim, synthetic grey. Suitable for Citroën 2CV. Length: 2,23 meters. This sealing trim was used also with the side windows in Citroën a AK, AZU, Dyane, HY. Made in France



Art.No.	Quality	needed qty
17422	3	3



Citroën HY 6310827

www.derfranzose.de

Window frame (sliding window), for the front door. Per piece. Suitable for Citroën HY, starting from year of construction 3/1967. Or. No. HY96181



Art.No.	Quality	needed qty
48089	3	2



Glass and metal adhesive, special glass-metal glue, mirrors adhesive and glass-on-glass adhesive. We searched for a long time and tried different products. This adhesive, which dries and hardens under UV light, is perfectly suited for fixing interior mirrors (rear-view mirrors) of a DS, window handles for sliding windows (Renault R4) or for the handles of triangular windows (VW T3, Alfa Romeo Spider, etc.). The adhesive is thick (gel-like) and should dry under the UV lamp (you also need 3x AAA batteries), also supplied with. As far as the adhesive has not been dried under the UV lamp, you can still make corrections (or wipe off excess adhesive). Of course, you can also use it to glue the handles of beer mugs or the bases of wine glasses! Technical details: Single-component adhesive that dries under UV light. Based on acrylate and polyurethane. The adhesive dries under UV light in the range of 320-400 nm within 15-20 seconds. The adhesive does not yellow. content of delivery: Acrybond adhesive 16 g. 1x UV lamp 1 W (batteries not included). Made in Germany. Believe us, if this adhesive had been available when we were young, we could have saved ourselves a lot of trouble..



Art.No.	Quality	needed qty
87984	1	1



Citroën
Dyane, HY, AMI 8

Knob (handle) for the sliding window. Suitable for Citroën Dyane, AMI 8 + HY. For 22mm bore in the window. The smooth part of the knob has a left-hand thread. Do not remove the metal pin that holds the spring inside. retaining nut against the glass (with 2 notches) = not right-handed



Art.No.	Quality	needed qty
16288	4	2



Knob for the sliding window. Suitable for Citroën HY + Citroën Dyane. The knob is without latching! For 8-12mm bore in the window.



Art.No.	Quality	needed qty
48181	3	2



500mm

www.derfranzose.de

Window seal vertical, between the sliding and the fixed glass pane. For the door in front (1 side with velvet). Suitable for Citroën HY, starting from year of construction 01/1968. Or. No. HY961-51A



Art.No.	Quality	needed qty
44833	3	2



Door window seal (rubber for sliding window), for Citroën HY. Per piece. On the left and on the right fitting. Dimension: 4.7 x 2.0 x 210cm. Or. No. H82489B



Art.No.	Quality	needed qty
48084	3	2

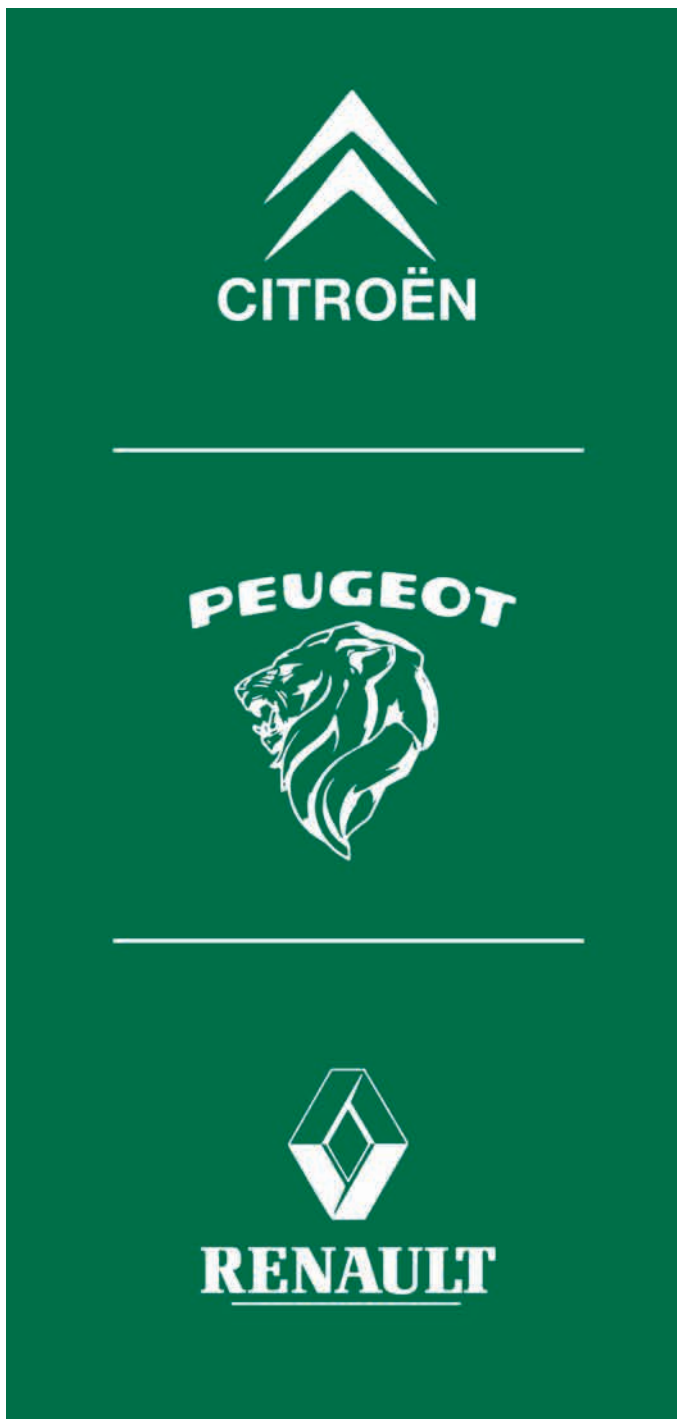

1

2

3

4

5

6

7

8

9

10

11

12

13

14

0714 remaining glazing

1
2
3
4
5
6
7
8
9
10
11
12
13
14



Back window seal - sealing trim, synthetic grey. Suitable for Citroën 2CV. Length: 2,23 meters. This sealing trim was used also with the side windows in Citroën a AK, AZU, Dyane, HY. Made in France



Art.No.	Quality	needed qty
17422	3	3



Label "Citroën préfère total" for the back window. Suitable for Citroën DS + 2CV. Dimension: 85 x 110mm.



Art.No.	Quality	needed qty
37070	3	1



Sticker "Citroën Total", in the rear window. For Citroën 2CV, CX, DS, GS. The label is stuck from the inside! Measurements: 32x250mm.



Art.No.	Quality	needed qty
16898	3	1



Glass and metal adhesive, special glass-metal glue, mirrors adhesive and glass-on-glass adhesive. We searched for a long time and tried different products. This adhesive, which dries and hardens under UV light, is perfectly suited for fixing interior mirrors (rear-view mirrors) of a DS, window handles for sliding windows (Renault R4) or for the handles of triangular windows (VW T3, Alfa Romeo Spider, etc.). The adhesive is thick (gel-like) and should dry under the UV lamp (you also need 3x AAA batteries), also supplied with. As far as the adhesive has not been dried under the UV lamp, you can still make corrections (or wipe off excess adhesive). Of course, you can also use it to glue the handles of beer mugs or the bases of wine glasses!



Art.No.	Quality	needed qty
87984	1	1



Black sealant putty, e.g. for sealing the windscreen of the Citroën DS. Dimensions: width 10mm, height 5mm, length 2500mm. This putty is also ideal for sealing openings in the engine front wall (cable ducts, choke cables, etc.).



Art.No.	Quality	needed qty
35032	2	1



Discs (windscreen) Pull-in tool (cord with handle). This is used to pull the rubber lip of the seal over the sheet metal fold. Very helpful!



Art.No.	Quality	needed qty
21114	3	1



Windshield seal (for one-piece windshield). Suitable for Citroën HY, starting from year of construction 02/1964. Or. No. HY96183



Art.No.	Quality	needed qty
48083	4	1



Windscreens (windscreen) piping assembly tool - bracket inserts. For small piping. There are 5 brackets in different widths so that narrow and wide piping can be fitted (e.g. for the 2CV, R4....). Suitable for tool with item number 20134.



Art.No.	Quality	needed qty
20137	3	1



Windscreen Installation Tool Set. Windshield sealing trim assembly tool. With this tools will the rubber lip (seal) inclination (spread) and it can fit the sealing trim at the same time. Attention: The tool is for very wide piping. For chrome piping e.g. Citroën 2CV, Renault R4 etc. small brackets must be fitted. See our item number 20137.



Art.No.	Quality	needed qty
20134	1	1



Permanently elastic window sealant. Original Teroson! 75ml tube. Application : Ideal for sealing rubber-mounted front, rear and side windows. Very stable, water resistant, remains elastic. Good adhesion even on damp windscreens.



Art.No.	Quality	needed qty
20966	2	1



Vehicle Window sealant permanent elastic. Original Teroson! Cartouche 310ml. Application: Ideally to sealing rubber-mounted front. - Tail and side windows. Very stably, water-resistant, remains elastic. Good adhesion also on wet disk.



Art.No.	Quality	needed qty
20967	2	1



Tugalin is a high-performance glass cleaner with long-term effect. It effortlessly removes soot and nicotine residues, oil and grease films, grease, dust, fingerprints, insect stains and much more from glass and all smooth surfaces. The nanoparticles leave an invisible protective layer on the cleaned surfaces, which delays resoiling and makes the next cleaning easier. Tugalin is a very powerful glass cleaner whose easy handling and streak-free results quickly make it an indispensable aid in industry, commerce and the home. 1000ml spray bottle. Made in Germany



Art.No.	Quality	needed qty
20666	2	1



Windshield seal (2 pieces). Suitable for Citroën HY, up to year of construction 2/1964 (splitted windshield) Or. No. H96183.



Art.No.	Quality	needed qty
48082	3	1



bouton pression
push-button
Druckknopf

Soft top hood, push-button completely, for riveting. Universal fitting.



Art.No.	Quality	needed qty
17115	2	



Back window seal - sealing trim, synthetic grey. Suitable for Citroën 2CV. Length: 2,23 meters. This sealing trim was used also with the side windows in Citroën a AK, AZU, Dyane, HY. Made in France



Art.No.	Quality	needed qty
17422	3	3



Roof for the driver's cab. Suitable for Citroën HY. Reproduction from GRP (synthetic). Or. No. H825-94. Dispatch only possible by shipping company!



Art.No.	Quality	needed qty
48357	3	1



Roof seam cover inclusive flanges ends. Suitable for Citroën HY. This sheet metal is about 1000mm long and covers the two roof halves. It is on the left and on the right a complete original flange in each case (with ends). You split this sheet metal and have then for front and rear the roof seam cover.



Art.No.	Quality	needed qty
44895	3	1



Roof half left complete, made of sheet metal! Suitable for Citroën HY with standard wheelbase. Shipping only possible by forwarding (relatively expensive). Dimension: 2750 x 950 x 1.0mm.



Art.No.	Quality	needed qty
48386	3	1



Roof half on the left, made of GRP. Suitable for Citroën HY. The roofs have an offset edge, so that several roofs can be extended. Dimension: 1830mm x 970mm. Or. No. H825-1



Art.No.	Quality	needed qty
44881	3	1



Roof half right complete, made of sheet metal! Suitable for Citroën HY with standard wheelbase. Shipping only possible by forwarding (relatively expensive). Dimension: 2750 x 950 x 1.0mm.



Art.No.	Quality	needed qty
48387	3	1



Roof half on the right, made of GRP. Suitable for Citroën HY. The roofs have an offset edge, so that several roofs can be extended. Dimension: 1830mm x 970mm. Or. Nr. H825-1A



Art.No.	Quality	needed qty
44882	3	1



Roof edge repair sheet metal. Suitable for Citroën HY. Length: 1000mm.



Art.No.	Quality	needed qty
48306	3	6



Loxx, snap fastener, upper part, on textile. Very simple and clever system, german invention from 1928. It works like a trailer coupling. The upper part catches a small ball and the system is locked. To open just pull up the upper part. No more broken fingernails! Just perfect.



Art.No.	Quality	needed qty
19035	2	



Loxx lower part for sheet metal. Sheet metal driving thread 4.2 x 16mm.



Art.No.	Quality	needed qty
19033	2	



Loxx, lower part for textiles. Original one, no reproduction.



Art.No.	Quality	needed qty
19034	2	



Sewing thread for outdoor use, for soft tops and sunroofs. 100% polyester continuous filament. Length: 3000 metres. Strength: 40. UV resistant, high tensile strength + low stretch, high abrasion resistance, washable and resistant to chemicals. Recommended needle size: 120-140.



Art.No.	Quality	needed qty
17141	1	1

NEW!



Section rubber adhesive + covering adhesives, in a brush box 350ml. Indispensably with work on one cover! Also premium for profile rubbers, full rubber, foam rubber, leather, lines, felt



Art.No.	Quality	needed qty
20492	2	1



Sliding door and rear flap reinforcement cross-beams (inside). Suitable for Citroën HY.



Art.No.	Quality	needed qty
48307	3	1

0717 tow coupling + accessories

0718 mirror



Tow trailer coupling for Citroën HY, starting from year of construction 11/1969. The coupling is delivery with EC-R55.01 checking! Trailer hitch tongue load: 75kg. Trailer weight: 1250kg. Total width: 970mm.



Art.No.	Quality	needed qty
48257	3	1



Flasher relay for trailer operation, 12 volts. French version! Pin assignment for French: Power supply symbol (+). Front and rear indicator connection = C symbol. Dashboard control light = R symbol. Additional control light connection = R2. Negative ground = -. If a Japanese relay is used: Plus + = X or B symbol. Connection of these indicators C = symbol L. Connection of control R = symbol P. Connection of German relay: 31 = ground = must be laid. 49 = input voltage = +. 49a = output voltage to indicator = R. C = control light = C. C2 = additional control light for trailer operation



Art.No.	Quality	needed qty
14114	3	1



Universal electric attachment kit for tow bars. Includes relay for French cars. 12 volts. 7-pin socket. Additional control light. Hella flasher relay connection: terminal + = positive supply/terminal 30, corresponds to the + sign on the 2CV relay. Terminal C = output of the indicator relay to the front and rear indicators, corresponds to terminal C on the 2CV indicator relay! Terminal R = connection of the control light. Terminal R2 = connection of an additional control light. Terminal - = ground, must be bolted to the vehicle! The 2CV indicator relay does not have this connection!



Art.No.	Quality	needed qty
14115	3	1



Electrical mounting kit universal, for tow trailer coupling. Inclusive Relay for French car. 6 Volt. 7 pole plug socket. Additional control light. Connection of the Hella flashing relay: Clamp 49 = plus supply, corresponds + to indications on 2CV the relay. 49a = outlet flashing relay clamps to indicator in front + rear, clamp corresponds to C on 2CV flashing relays! C2 = connection clamps additional control light. Clamp 31 = earth, must be screwed on to vehicle! This port do not have the 2CV flashing relay! The original control light, in the vehicle, you must parallel on the clamp 49a scolded! Electronic kit universal for trailer towing device, incl. relay for French cars, 7 pole plug socket



Art.No.	Quality	needed qty
14688	3	1



Electrical wiring harness universal, for tow trailer coupling. Note: Only cables + socket! Without flasher, without control light. 7 cores.



Art.No.	Quality	needed qty
14151	4	1



Control light green, turn light indicator to use with a tow trailer coupling. 12 V.



Art.No.	Quality	needed qty
14167	3	1



Metal plug, seven poles, for the trailer



Art.No.	Quality	needed qty
14116	3	1



Plug socket, metal, seven poles, at trailer towing coupling



Art.No.	Quality	needed qty
14117	3	1

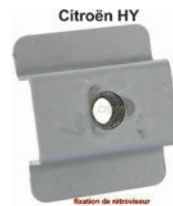

Mirror bracket reinforcement at the top of the door. This bracket fits at the top of the door, and is mounted above the bead. Suitable for Citroën HY.



Art.No.	Quality	needed qty
48390	3	2



Mirror with securing clip, without fixture arm. Suitable for Citroën HY, to year of construction 1971. Made in France



Art.No.	Quality	needed qty
47000	2	2



Mirror for clamping to the door. Made entirely of metal. Typical door mirror, as often used in the 1940s and 1950s (Citroën 11CV, Peugeot, Renault). Diameter: approx. 95 mm. Suitable for left and right!



Art.No.	Quality	needed qty
50204	3	2



Mirrors to attach at the door. Completely made of metal. Typical door mirror, how it installed very often in the forties and fifties. Diameter: about 100mm.



Art.No.	Quality	needed qty
50211	3	2



Mirror, 2 pieces (1x on the left + 1x on the right). Suitable for Citroën HY. Dimension: 170 x 130mm.



Art.No.	Quality	needed qty
47151	3	1



Mirror glass, suitable for Citroën HY, to year of construction 1971! Made in France



Art.No.	Quality	needed qty
47001	3	1

0 = New old stock
1 = Good
2 = Original

3 = Advanced replica
4 = Replica
5 = Mediocre replica

1
2
3
4
5
6
7
8
9
10
11
12
13
14

8

body covering

dashboard lining	0801
inside lining, head lining, rear window shelf + trunk	0802
sun screen, inside mirror	0803
seat belts	0804
seat covers front	0805
seat covers rear	0806
complete seat covers (sets)	0807
seat frame + attachments	0808
upholstery + suspension seats + material	0809
door trim	0810
carpet sets + floor mats	0811
insulating mats generally	0812

1

2

3

4

5

6

7

8

9

10

11

12

13

14





Label, for the gear shift at the dashboard. Old version. Suitable for Citroën HY.



Art.No.	Quality	needed qty
44889	3	1



Label, for the gear shift at the dashboard. New version. Suitable for Citroën HY.



Art.No.	Quality	needed qty
44890	3	1



Citroën emblem (Chevron) on the dashboard. Suitable for Citroën 11CV + 15CV, up to year of construction 02/1952. Or. No. 802594. Dimension: 38 x 40mm. The emblem can also be used universal.



Art.No.	Quality	needed qty
60160	3	1



expanding rivet with safety pin. (3,5mm) 100 pieces!



Art.No.	Quality	needed qty
18421	2	1



expanding rivet with safety pin. (5,5mm) 30 pieces!



Art.No.	Quality	needed qty
18423	2	1



Rosette 13/5mm with screw. Contents: 12 pieces + 12x screw 4mm/16mm. This rosette consists only of a punched-out sheet metal which has been nickel-plated. They are not as sturdy and pretty as our numbers 21143, 21144, 21145, but these rosettes are more like the original rosettes used in early Citroën 2CV, R4, Dauphine etc. Higher-quality vehicles were more likely to have our shiny alternatives (e.g. Citroën DS).



Art.No.	Quality	needed qty
21179	4	1



Rosette nickel plated. For 4mm screw. Outside diameter: 11mm. Height: 2,4mm. These rosettes were used for dashboard, door linings. Suitable for Citroën 2CV, DS, HY and in many Peugeot + Renault. Our rosettes are shiny and flanged at the back. This makes them very stable.



Art.No.	Quality	needed qty
21144	3	1



Rosette nickel plated. For 4mm screw. Outside diameter: 12,7mm. Height: 2,5mm. These rosettes were used for dashboard, door linings. Suitable for Citroën 2CV, DS, HY and in many Peugeot + Renault. Our rosettes are shiny and flanged at the back. This makes them very stable.



Art.No.	Quality	needed qty
21145	3	1



Rosette nickel plated. For 5mm screw. Outside diameter: 13mm. Height: 3,0mm. These rosettes were used for dashboard, door linings. Suitable for Citroën 2CV, DS, HY and in many Peugeot + Renault. Our rosettes are shiny and flanged at the back. This makes them very stable.



Art.No.	Quality	needed qty
21143	3	1



Screw cross lens head (4.8x22) in stainless steel. Per piece.



Art.No.	Quality	needed qty
21166	3	4



Screw cross lens head (4.8x32) in stainless steel. Per piece.



Art.No.	Quality	needed qty
21167	3	4



Speedometer cable complete. Suitable for Citroën HY. Length: 2350mm.



Art.No.	Quality	needed qty
48003	3	1



0802 body inside lining, head lining, rear window shelf + trunk

0803 sun screen, inside mirror



Anti-slip mat 120 x 100cm (Luggage compartment mat). Individually cuttable. Nothing slips in curves or by brake; anti-slip-coats on both sides. For car, boat, caravan



Art.No.	Quality	needed qty
18908	3	1



Inside roof lining adhesive from Teroson. Contents: 680g. Light, transparent adhesive material for the roof and door linings.



Art.No.	Quality	needed qty
21059	2	1



Edge protection, U-profile universal. By meters, 13 mm wide. For clamping range 1-4mm. Color black. Customer cut return not possible!



Art.No.	Quality	needed qty
19036	3	1



Edge protection, U-profile universal. By meters, 13 mm wide. For clamping range 5-8mm. Color black. Customer cut return not possible!



Art.No.	Quality	needed qty
19037	3	1



Engine tunnel lining, suitable for Citroën HY. Vinyl brown.



Art.No.	Quality	needed qty
48021	3	1



Engine tunnel lining, suitable for Citroën HY. Vinyl black.



Art.No.	Quality	needed qty
48020	3	1



Engine tunnel lining, suitable for Citroën HY. Leather brown.



Art.No.	Quality	needed qty
48311	1	1



Engine tunnel lining, suitable for Citroën HY. Leather black.



Art.No.	Quality	needed qty
48312	1	1



Section rubber adhesive + covering adhesives, in a brush box 350ml. Indispensably with work on one cover! Also premium for profile rubbers, full rubber, foam rubber, leather, lines, felt



Art.No.	Quality	needed qty
20492	2	1



Spray adhesive, 500ml. Very useful for affixing of interior lining, damming mats, hoods etc. High adhesive. We have been searching for a long time since we found a really good one.



Art.No.	Quality	needed qty
20011	1	1



Glass and metal adhesive, special glass-metal glue, mirrors adhesive and glass-on-glass adhesive. We searched for a long time and tried different products. This adhesive, which dries and hardens under UV light, is perfectly suited for fixing interior mirrors (rear-view mirrors) of a DS, window handles for sliding windows (Renault R4) or for the handles of triangular windows (VW T3, Alfa Romeo Spider, etc.). The adhesive is thick (gel-like) and should dry under the UV lamp (you also need 3x AAA batteries), also supplied with. As far as the adhesive has not been dried under the UV lamp, you can still make corrections (or wipe off excess adhesive). Of course, you can also use it to glue the handles of beer mugs or the bases of wine glasses! Technical details: Single-component adhesive that dries under UV light. Based on acrylate and polyurethane. The adhesive dries under UV light in the range of 320-400 nm within 15-20 seconds. The adhesive does not yellow. content of delivery: Acrybond adhesive 16 g. 1x UV lamp 1 W (batteries not included). Made in Germany. Believe us, if this adhesive had been available when we were young, we could have saved ourselves a lot of trouble..



Art.No.	Quality	needed qty
87984	1	1



Inside mirror chromium-plates. Dimension about: 125 x 55mm. The mirror does not have a fixture, only a moving threaded bolt with M5 thread.



Art.No.	Quality	needed qty
50212	3	1

0804 seat belts

Citroën 2CV + DS



Safety belt in front statically (without retractor mechanism), on the left + on the right fitting. This belt was installed in Citroën 2CV + Citroën DS in the sixties and seventies. All the seat belts we offer are made in England. Strictly according to European car industry specifications, and of course have the required test marks. Your safety is close to our hearts. Therefore, we do not import cheap safety belts from Asia!



Art.No.	Quality	needed qty
18149	4	2

seat covers front 0805

seat frame + attachments 0806



Covering brown, from genuine leather (on the left of or on the right fitting). Suitable for Citroën HY, starting from year of construction 09/1970 (3 series).



Art.No.	Quality	needed qty
48310	1	2



Covering brown, from vinyl (on the left of or on the right fitting). Suitable for Citroën HY, starting from year of construction 09/1970 (3 series).



Art.No.	Quality	needed qty
48051	3	2



Covering brown, from vinyl (on the left of or on the right fitting). Suitable for Citroën HY, from year of construction 10/1968 to 09/1970 (2 series).



Art.No.	Quality	needed qty
48223	3	2



Covering brown, from vinyl (on the left of or on the right fitting). Suitable for Citroën HY, from year of construction 1949 to 10/1968 (1 series).



Art.No.	Quality	needed qty
48225	3	2



Covering black, from genuine leather (on the left of or on the right fitting). Suitable for Citroën HY, starting from year of construction 09/1970 (3 series).



Art.No.	Quality	needed qty
48275	1	2



Covering black, from vinyl (on the left of or on the right fitting). Suitable for Citroën HY, starting from year of construction 09/1970 (3 series).



Art.No.	Quality	needed qty
48050	3	2



Covering black, from vinyl (on the left of or on the right fitting). Suitable for Citroën HY, of year of construction 10/1968 to 09/1970 (2 series).



Art.No.	Quality	needed qty
48224	3	2



Covering black, from vinyl (on the left of or on the right fitting). Suitable for Citroën HY, from year of construction 1949 to 10/1968 (1 series).



Art.No.	Quality	needed qty
48226	3	2



Cylinder pin for the front seat. Suitable for Citroën 11CV + Citroën HY. Dimension: 6 x 32mm.



Art.No.	Quality	needed qty
60566	3	4



Rubber ring hooks, for upholstery (50 pieces). Long version. Suitable for Citroën 2CV, Dyane, HY.



Art.No.	Quality	needed qty
18172	3	320



Rubber ring with hook, for the upholstery of the seats. 50 pieces! Very good quality from the original manufacturer. These rubber rings are slightly more elastic, softer, than the replica rubber rings (18026). Suitable for Citroën 2CV, Dyane, HY. Or. No. A922114.



Art.No.	Quality	needed qty
18442	2	4



Rubber ring with hook, for upholstering the seats. Per piece. Replica. Suitable for Citroën 2CV, Dyane, HY. The replica rubber rings are somewhat tighter, harder, than the original rubber 18442. Or. No. A922114. In the 2CV seat there are 22 rubbers in the lower seat and 26 rubbers in the backrest. There are approx. 100 rubbers in a seat bench.



Art.No.	Quality	needed qty
18026	3	176



Rubber cylinder, for the seat adjustment. Suitable for Citroën 11CV/15CV, Citroën HY. Dimension: 22 x 27,5mm. Or. No. 233163



Art.No.	Quality	needed qty
60499	3	8



Child seat covering, brown. Suitable for Citroën HY. Suitable for child seat rack 48358.



Art.No.	Quality	needed qty
48360	3	1



Child seat covering, black. Suitable for Citroën HY. Suitable for child seat rack 48358.



Art.No.	Quality	needed qty
48359	3	1



Child seat in front. Suitable for Citroën HY. Reproduction of the original accessory. No permission as child seat in Germany! Without cover.



Art.No.	Quality	needed qty
48358	3	1



Knob round, colour grey, screwable, for heating adjustment and air distribution, bench lock. Reproduction made of metal! Suitable for Citroën 2CV, DS, HY.



Art.No.	Quality	needed qty
14526	3	

0809 upholstery + suspension seats + material

1
2
3
4
5
6
7
8
9
10
11
12
13
14

Citroën HY



Latching pin, which is inserted from above into the seat slide. Suitable for Citroën HY. It prevents the seat frame from slipping out of the seat rail. Or. No. HY841-122



Art.No.	Quality	needed qty
44834	3	2



Hog Ring Pliers for use with A7 Hog Rings (Part No 21049). Complete with automatic feed. Ideal for continuous connections. Single handed operation. Ideal for upholstery on classic cars.



Art.No.	Quality	needed qty
21048	1	1



Hog ring plier for the mounting of coverings (workshop quality). With this pliers the hog ring's 18420 are optimally treated.



Art.No.	Quality	needed qty
18084	3	1



Foam material plates (2 fittings) 15mm thick, 1200x600mm. Universal for seats, carpet, door linings etc. Made in Germany



Art.No.	Quality	needed qty
78042	3	1



Foam material plates (2 pieces) 15mm thick, 580x580mm. Universal for seats, carpet, door linings etc. Made in Germany



Art.No.	Quality	needed qty
78041	3	1



Inclination rivet 3mm.



Art.No.	Quality	needed qty
17136	3	



Padding set seat in front. Consisting of: Jute clamping cover with felt underlays, foam material. Suitable for 1 seat. For Citroën HY.



Art.No.	Quality	needed qty
48345	3	2



Rubber ring hooks, for upholstery (50 pieces). Long version. Suitable for Citroën 2CV, Dyane, HY.



Art.No.	Quality	needed qty
18172	3	320



Rubber ring with hook, for the upholstery of the seats. 50 pieces! Very good quality from the original manufacturer.

These rubber rings are slightly more elastic, softer, than the replica rubber rings (18026). Suitable for Citroën 2CV, Dyane, HY. Or. No. A922114.



Art.No.	Quality	needed qty
18442	2	4



Rubber ring with hook, for upholstering the seats. Per piece. Replica. Suitable for Citroën 2CV, Dyane, HY. The replica rubber rings are somewhat tighter, harder, than the original rubber 18442. Or. No. A922114. In the 2CV seat there are 22 rubbers in the lower seat and 26 rubbers in the backrest. There are approx. 100 rubbers in a seat bench.



Art.No.	Quality	needed qty
18026	3	176



Clip (200 fittings) for the coverings. Suitable for Citroën, Peugeot, Renault. If the seats are again upholstered, this clip is required. The suitable pliers have our number 18084.



Art.No.	Quality	needed qty
18420	2	1



Hog Rings (500 per pack) for 21048 automatic pliers (coverings). Suitable for Citroën, Peugeot, Renault. The suitable pliers have our number 21048.



Art.No.	Quality	needed qty
21049	1	1



Clip for the securement of the coverings at the seat frame. (slide-on clamp with hooks). Suitable for Citroën 2CV, Dyane, Ami, DS, HY.



Art.No.	Quality	needed qty
18182	3	

carpet sets + floor mats 0811

Citroen HY



Sealing rubber for the gear shift lever, in the interior. Suitable for Citroën HY. Or. No. HY334-82



Art.No.	Quality	needed qty
48333	3	1



Carpet set anthracite, suitable for Citroën HY starting from year of construction 04/1969.



Art.No.	Quality	needed qty
48273	3	1



Carpet set anthracite, suitable for Citroën HY, to year of construction 04/1969.



Art.No.	Quality	needed qty
48281	3	1



Carpet set Velour dark grey. Suitable for Citroën HY, starting from year of construction 04/1969. Very high-quality! Made in Germany



Art.No.	Quality	needed qty
48362	3	1



Screw cross lens head (4.8x22) in stainless steel. Per piece.



Art.No.	Quality	needed qty
21166	3	4



Screw cross lens head (4.8x32) in stainless steel. Per piece.



Art.No.	Quality	needed qty
21167	3	4

door trim 0810

carpet sets + floor mats 0811



Rosette 13/5mm with screw. Contents: 12 pieces + 12x screw 4mm/16mm. This rosette consists only of a punched-out sheet metal which has been nickel-plated. They are not as sturdy and pretty as our numbers 21143, 21144, 21145, but these rosettes are more like the original rosettes used in early Citroën 2CV, R4, Dauphine etc. Higher-quality vehicles were more likely to have our shiny alternatives (e.g. Citroën DS).



Art.No.	Quality	needed qty
21179	4	1



Rosette nickel plated. For 4mm screw. Outside diameter: 11mm. Height: 2,4mm. These rosettes were used for dashboard, door linings. Suitable for Citroën 2CV, DS, HY and in many Peugeot + Renault. Our rosettes are shiny and flanged at the back. This makes them very stable.



Art.No.	Quality	needed qty
21144	3	



Rosette nickel plated. For 4mm screw. Outside diameter: 12,7mm. Height: 2,5mm. These rosettes were used for dashboard, door linings. Suitable for Citroën 2CV, DS, HY and in many Peugeot + Renault. Our rosettes are shiny and flanged at the back. This makes them very stable.



Art.No.	Quality	needed qty
21145	3	



Rosette nickel plated. For 5mm screw. Outside diameter: 13mm. Height: 3,0mm. These rosettes were used for dashboard, door linings. Suitable for Citroën 2CV, DS, HY and in many Peugeot + Renault. Our rosettes are shiny and flanged at the back. This makes them very stable.



Art.No.	Quality	needed qty
21143	3	



© www.michaelleuf.com

0812 insulating mats generally

1
2
3
4
5
6
7
8
9
10
11
12
13
14



Bitumen mats (anti-roar plates) self adhesive, 6 plates. 550 x 250mm. Universal fitting.



Art.No.	Quality	needed qty
18029	3	



Noise damming mats self adhesive. Color grey. Measurements: 1000 X.500 x 11mm. Stuffing contents: 2x damming mat. Universal fitting.



Art.No.	Quality	needed qty
18028	3	1



Interior insulation mat (approx 10mm thick), self adhesive, optically as from the years 60s to approx. end of the 70s. Dimensions: approx. 115 x 55cm (about 600g/m²). These mats have the greenish colour of the original felt mats (made from recycled cotton fibres), but have been manufactured according to today's automotive technology. Flame retardant, no harmful vapours! Completely "Made in Germany". These mats were installed in firewalls, doors, side panels, boot. For the vehicle floor we recommend the mats with a heavy layer (bitumen-like). We have been looking for them for a long time, and finally found some!



Art.No.	Quality	needed qty
18031	1	



Interior insulation mat (approx 15mm thick), self adhesive, optically as from the years 60s to approx. end of the 70s. Dimensions: approx. 115 x 55cm (about 900g/m²). These mats have the greenish colour of the original felt mats (made from recycled cotton fibres), but have been manufactured according to today's automotive technology. Flame retardant, no harmful vapours! Completely "Made in Germany". These mats were installed in firewalls, doors, side panels, boot. For the vehicle floor we recommend the mats with a heavy layer (bitumen-like). We have been looking for them for a long time, and finally found some!



Art.No.	Quality	needed qty
18032	1	



Interior insulation mat (approx 20mm thick), self adhesive, optically as from the years 60s to approx. end of the 70s. Dimensions: approx. 115 x 55cm (about 1200g/m²). These mats have the greenish colour of the original felt mats (made from recycled cotton fibres), but have been manufactured according to today's automotive technology. Flame retardant, no harmful vapours! Completely "Made in Germany". These mats were installed in firewalls, doors, side panels, boot. For the vehicle floor we recommend the mats with a heavy layer (bitumen-like). We have been looking for them for a long time, and finally found some!



Art.No.	Quality	needed qty
18033	1	

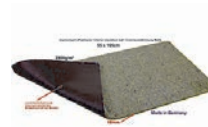

Interior insulation mat for the floor (10mm thick), optically as from the years 60s to approx. end of the 70s. Dimensions: approx. 105 x 55cm (approx. 2900g/m²). These mats have the greenish colour of the original felt mats, with an additional heavy layer (modern bitumen, does not age, does not crack, UV resistant, water repellent, state-of-the-art automotive technology, but with the look of the old days!) The insulation material is flame retardant, no harmful vapours! Completely "Made in Germany". These mats are laid on the vehicle floor or cardan tunnel. Heavy layer to the carpet side! The heavy layer also prevents "droning noises". The mats can be deformed by heat and adapt to the contours.



Art.No.	Quality	needed qty
18036	1	

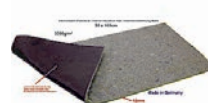

Interior insulation mat for the floor (approx 15mm thick), optically as from the years 60s to approx. end of the 70s. Dimensions: approx. 105 x 55cm (approx. 3200g/m²). These mats have the greenish colour of the original felt mats (made from recycled cotton fibres), with an additional heavy layer (modern bitumen, does not age, does not crack, UV resistant, water repellent, state-of-the-art automotive technology, but with the look of the old days!) The insulation material is flame retardant, no harmful vapours! Completely "Made in Germany". These mats are laid on the vehicle floor or cardan tunnel. Heavy layer to the carpet side! The heavy layer also prevents "droning noises". The mats can be deformed by heat and adapt to the contours.



Art.No.	Quality	needed qty
18034	1	



Interior insulation mat for the floor (approx 20mm thick), optically as from the years 60s to approx. end of the 70s. Dimensions: approx. 105 x 55cm (approx. 3500g/m²). These mats have the greenish colour of the original felt mats (made from recycled cotton fibres), with an additional heavy layer (modern bitumen, does not age, does not crack, UV resistant, water repellent, state-of-the-art automotive technology, but with the look of the old days!) The insulation material is flame retardant, no harmful vapours! Completely "Made in Germany". These mats are laid on the vehicle floor or cardan tunnel. Heavy layer to the carpet side! The heavy layer also prevents "droning noises". The mats can be deformed by heat and adapt to the contours.



Art.No.	Quality	needed qty
18035	1	



0 = New old stock
1 = Good
2 = Original
3 = Advanced replica
4 = Replica
5 = Mediocre replica

9

chemistry + lacquer

lacquer 1 liter	0901
color spray cans	0902
lacquer chemicals	0903
rust inhibitor + body sealing	0904
gasoline additive	0905
useful chemistry	0908

1

2

3

4

5

6

7

8

9

10

11

12

13

14

1
2
3
4
5
6
7
8
9
10
11
12
13
14





Chassis paint spray can 400ml colour black matt, best for chassis parts, lasting flexibility



Art.No.	Quality	needed qty
20477	3	



Handhold for lacquer aerosol spray. Facilitates exactly and controlled allotting of the spray. A real alleviation.



Art.No.	Quality	needed qty
20897	1	1



clear coat 400ml spray can. In case of metallic paint always paint an additional layer of clear coat on top, this is the only way that the paint is hardening



Art.No.	Quality	needed qty
20445	3	



paint spray can 400ml colour black brilliant, best for chassis parts, since lasting flexibility



Art.No.	Quality	needed qty
20476	3	



Spraying varnish 400ml, LHM green. Approximate varnish (RAL 6005). Corresponds rather accurately to the original varnish tone AC502.



Art.No.	Quality	needed qty
39431	3	1



Spraying varnish 400ml, chocolate-brown for DS + SM. With DS for: Ventilation connecting piece in the bumper, crossbeam in front, cover sheets in the wheel house, shields before hydraulics, fixture in the engine compartment etc.. Please use up it within 6 months!



Art.No.	Quality	needed qty
39430	3	1



spray paint rim silver 500ml



Art.No.	Quality	needed qty
20461	3	



heat-resistant spray paint till 650°C 400ml, colour silver



Art.No.	Quality	needed qty
20467	3	



heat-resistant spray paint till 800°C 400ml, colour anthracite



Art.No.	Quality	needed qty
20469	3	



heat-resistant spray paint till 800°C, 400ml, colour black



Art.No.	Quality	needed qty
20466	3	



spray paint black brilliant 500ml



Art.No.	Quality	needed qty
20460	3	



spray paint black matt 500ml



Art.No.	Quality	needed qty
20459	3	



1

2

3

4

5

6

7

8

9

10

11

12

13

14

0903 lacquer chemicals



fine filler with hardener can 250g, colour white



Art.No.	Quality	needed qty
20473	3	



Hardener AK 210, 1 litre, for lacquers. Weight ratio 2 parts lacquer, 1 part hardener. Not for metallic lacquers!!!!



Art.No.	Quality	needed qty
20438	3	



filler spray can 400ml fitting to our paints



Art.No.	Quality	needed qty
20456	3	



hardener for filler, tube 25g.



Art.No.	Quality	needed qty
20475	3	



smooth filler NC combination, tube 100g, dark grey



Art.No.	Quality	needed qty
20474	3	



Sikaflex 221, 300ml, cartouche. Adhesion-strong sealing compound, for sealing sheet metal overlaps (sheet metal grooves). Color: black. Overpaintable.



Art.No.	Quality	needed qty
20022	1	



prime coat spray can 500ml, colour grey, fitting to our spray paints, for light enamels (top coatings)



Art.No.	Quality	needed qty
20454	3	



silicon remover, painting preparation, (removes grease and Silikon) 500ml



Art.No.	Quality	needed qty
20443	3	



rust inhibitor + body sealing 0904



Ballistol oil 200ml bottle. The universal oil, long-proven and unequalled. Optimally for rust protection, maintenance of precision mechanics, in addition, leather, wood etc. (Ballistol is also well-known as weapon oil) Ballistol gumming also after year not. To show for rust protection very easily with brush lubricator.



Art.No.	Quality	needed qty
20910	2	1

bouchon obturateur de carrosserie
body plug - cavity-preservation
Karosseriestopfen - Hohlraum Konservierung



8mm

Blind plug - body plug conical, 8mm. For sealing or closing holes (cavity preservation). Good resistance against corrosion, weathering, ageing, ozone, oils, petrol splashes and solvents. Contains no silicone (important for possible painting work). Super easy to use, no fiddling.



Art.No.	Quality	needed qty
20239	3	1



12mm

rubber plug, 12mm to close e.g. drillings for cavity sealings. For sheet metals to 2mm strength



Art.No.	Quality	needed qty
20192	3	1



14mm

rubber plug, 14 mm, to close e.g. drillings for cavity sealings. For sheet metals to 2mm strength



Art.No.	Quality	needed qty
20193	3	1



18mm

rubberplug, 18mm to close e.g. drillings for cavity sealings. For sheet metals to 2mm strength



Art.No.	Quality	needed qty
20194	3	1



6mm

rubber plug, 6mm, to close e.g. drillings for cavitysealing. For sheet metals to 2mm strength



Art.No.	Quality	needed qty
20189	3	1



8mm

rubber plug, 8mm, to close e.g. drillings for cavity sealing. For sheet metals to 2mm strength



Art.No.	Quality	needed qty
20190	3	1



10mm

rubber plug, 100 to close e.g. drillings for cavity sealings. For sheet metals to 2mm strength



Art.No.	Quality	needed qty
20191	3	1



pressure spray gun cavity with hook and cavity nozzle, incl. pre-heating device for Mike Sander grease



Art.No.	Quality	needed qty
20083	3	1



Semi-fluid grease 4kg, for preserving the cavity, Mike Sander - corrosion inhibitor !



Art.No.	Quality	needed qty
20002	1	1



Semi-fluid grease 750g, for preventing the cavity, Mike Sander - corrosion inhibitor



Art.No.	Quality	needed qty
20003	1	1



Fluid film AS-R 400ml spray can. Long-term corrosion protection + penetrating oil. The can is delivery with a 15cm long spray pipe. Optimally for underbody coating, hollow spaces etc.. A suitable cavity probe is supplyable under the No. 21129. Viscosity: low like syrup.



Art.No.	Quality	needed qty
21127	1	1



Priming, penetrable, for sheet metal parts. 400ml



Art.No.	Quality	needed qty
20056	3	1



Cavity preservation on wax basis, for cavity pistol, 1 litre.



Art.No.	Quality	needed qty
20005	3	1



Body cavity protection spray, 500 ml. Inclusive hollow space probe



Art.No.	Quality	needed qty
20057	3	1



Cavity probe (60cm) for fluid film spray can (21127)



Art.No.	Quality	needed qty
21129	1	1



Popular assortment of rubber Wiring & Blanking grommets. Wiring Grommets from 6mm to 16mm. Blanking Grommets from 8mm to 25mm. Box Qty 240



Art.No.	Quality	needed qty
60295	3	1



Fertan rust converter, 1 litre, Fertan the market leader with rust-converting primer!



Art.No.	Quality	needed qty
20030	1	1

0904 rust inhibitor + body sealing

0905 gasoline additive



Sikaflex 221, 300ml, cartouche. Adhesion-strong sealing compound, for sealing sheet metal overlaps (sheet metal grooves). Color: black. Overpaintable.



Art.No.	Quality	needed qty
20022	1	



stone guard MOTIP, colour grey for spray gun, 1000ml



Art.No.	Quality	needed qty
20014	3	



Underbody coating nozzle (gun) + cavity preservation nozzle (gun), for 1 liter of doses, very high quality.



Art.No.	Quality	needed qty
20123	3	



Underbody coating + stone guard to squirt, for underbody protection pistol. 1000ml



Art.No.	Quality	needed qty
20006	3	



Underbody coating to paint with brush, 1000ml



Art.No.	Quality	needed qty
20007	2	



Zinc primer, 400ml.



Art.No.	Quality	needed qty
20491	2	

0905 gasoline additive

stabilisateur d'essence + octane booster
Fuel stabiliser + fuel additive - octane booster
Benzinestabilisator + Klopffestigkeit - Oktanbooster



NEW!

Fuel stabiliser - fuel additive - octane booster from ELF/Total, for winter storage and storage of all 2 and 4-stroke engines. Ideal for our classic cars.



Prevents corrosion in the tank and in the entire fuel system. Antioxidants prevent the fuel from ageing (the petrol remains ignitable). Binds and neutralises condensation in the tank. Eliminates starting difficulties when the vehicle has not been used for a long time. And as a special feature, the petrol additive has an octane booster. It therefore increases the ignitability of the petrol (knock resistance). Particularly interesting for regions in this beautiful world where there is no super petrol with at least 98 octane, or if you are involved in motor sports! Packaged in a high-quality aluminium can. Contents: 150ml. Application: 150ml is sufficient for 20 litres of petrol. Fill the tank completely. Fill in the fuel additive. Run the engine for 10 minutes. Done!

Art.No.	Quality	needed qty
21174	1	1



Gasoline stabilizer 250ml. Preserves and protects the fuel from ageing and oxidation. Prevents corrosion in the entire fuel system. Ensures problem-free immobilization of vintage cars, convertibles, motorcycles, scooters, quads, lawnmowers, chainsaws, and other petrol-driven 2-stroke and 4-stroke engines. Increases operational safety. With long-term effect. 25 ml from the dosing device preserve 5 l fuel. Before decommissioning, add the appropriate quantity to the tank and allow the engine to run for approx. 10 minutes.



Art.No.	Quality	needed qty
10617	2	1



Lead substitute (fuel additive) for older petrol engines, replaces the lubricating effect of the lead. 250ml bottle



Art.No.	Quality	needed qty
20087	1	



0904 rust inhibitor + body sealing

0 = New old stock
1 = Good
2 = Original

3 = Advanced replica
4 = Replica
5 = Mediocre replica



Exhaust sealing compound 200g. For sealing larger holes, gaps, cracks. Relatively tough material. It hardens!



Art.No.	Quality	needed qty
20483	3	1



Exhaust assembly paste 150g. For sealing the plug-in connections when mounting exhaust pipes. The compound hardens when heated. Very helpful!



Art.No.	Quality	needed qty
20485	3	1



Battery pole grease, 50g tube.



Art.No.	Quality	needed qty
20943	3	1



Brakes cleaner 500ml, spray bottle, removes even other filth,



Art.No.	Quality	needed qty
20009	3	1



Kunststoff-Teufel® is a highly active and electrolytic cleaning agent. It effortlessly removes the strongest grease and oil stains, nicotine, soot, burnt-in stains and much more from plastics and other alkali-resistant surfaces. An antistatic and dirt-repellent surface is left on the cleaned surfaces. Kunststoff-Teufel® is the perfect cleaner for household, hobby and business (e.g. ideal for cleaning kitchens, blinds, caravans, garden furniture, tarpaulins, car and truck interiors etc.). 1000ml spray bottle! We ourselves only work with the "Teufelsreiniger" (devil's cleaner). We have only had the best experiences. Made in Germany



Art.No.	Quality	needed qty
20969	2	1



Distilled water, 1 litre



Art.No.	Quality	needed qty
20012	3	1



Distilled water, 5 liters. For radiator filling. Tap water contains harmful components for the cooling circuit. For mixing the antifreeze fluid, please take care to use distilled water. It improves the adhesion of corrosion-blocker in your cooling system.



Art.No.	Quality	needed qty
20556	3	1



Molybdenum universal grease in tube, 100g. High performance rolling bearing grease for lubricating wheel bearings, cardan joints etc.



Art.No.	Quality	needed qty
20291	3	1



Fire extinguisher 1kg. The "Auto & Bike" fire extinguisher is designed for extinguishing fires in cars, lorry cabins, motorhomes and motorbikes and can also be used on electrical appliances with a voltage of up to 1000 volts. It can be carried in the car or stored in the garage at temperatures from -15° to max. 60°C. Certified extinguishing capacity of (21B/3A). GS (German test mark) tested, tested by the fire brigade, used by the police, no minimum durability date! Cannot be used against grease fires!!! Super useful in the car and especially in the workshop! (welding work)



Art.No.	Quality	needed qty
20935	1	1



Fluid metal, 25ml to fill up cracks, holes, cavities. For repairing tubes, tanks, screw threads etc. Applicable on iron, cast iron parts, aluminium. Oil, petrol, water and alcohol immune. Can be polished, sawed and drilled after hardening!



Art.No.	Quality	needed qty
21017	3	1



Liquid metal 50ml. It is called liquid metal or cold metal. But the correct name is 2-component epoxy resin. We wouldn't want to be without it in our car first-aid kit and it has helped us many times with minor breakdowns. The 2K material hardens very quickly. It can be sanded, drilled and threaded afterwards. Resistant to water, oil, fuel and many chemicals. Sandable and paintable. Very easy to use thanks to a mixing tube supplied. Other mixing tubes are also available (if you don't need the whole tube).



Art.No.	Quality	needed qty
21084	1	1



Liquid metal mixing tubes (3 set). Suitable for our item number 21084.



Art.No.	Quality	needed qty
21085	1	1

DerFranzose

Citroën Peugeot Renault
www.franzose.com

0908 useful chemistry



GLACEELF CARTECH antifreeze concentrate from Total (must be mixed with distilled water). Suitable for classic engines that also have aluminium and/or copper components (radiator, cylinder head, etc.). Reliable protection against rust, corrosion, foaming and cavitation. Mixing ratio: 50% antifreeze + 50% distilled water. Attention: This is a new antifreeze from TOTAL that replaces the antifreeze "GLACEELF Auto Supra" (CLACELF contains borates, which are no longer permitted in the EU). The two antifreezes can be mixed together. But be careful: CARTECH antifreeze is only mixable with GLACEELF Auto Supra from TOTAL. CARTECH is not mixable with antifreeze from other manufacturers. But it is best to replace the antifreeze completely with TOTAL CARTECH! General information: Amines, nitrites and borates are no longer allowed under the new EU CLP regulations. In addition, 2-ethylhexanoic acids must be removed because they are suspected of being harmful to human reproduction (or in short: it making you impotent!)



Art.No.	Quality	needed qty
21157	2	4



Graphitic oil, lock oil. Optimally to clean and lubricate locks (door lock, starter lock etc.). 50ml.



Art.No.	Quality	needed qty
20927	3	1



Priming, penetrable, for sheet metal parts. 400ml



Art.No.	Quality	needed qty
20056	3	



Hand washing cream, 500ml



Art.No.	Quality	needed qty
20180	1	

remaining stock!
while stock lasts!



Inside roof lining adhesive from Teroson. Contents: 680g. Light, transparent adhesive material for the roof and door linings.



Art.No.	Quality	needed qty
21059	2	1



Copper paste 100gr.



Art.No.	Quality	needed qty
20028	3	1



LOCTITE 243, liquid screw protection, middle strong, indispensable for all car work



Art.No.	Quality	needed qty
20026	2	1



Engine sealing compound grey, to 340°, 85ml, silicone basis. Optimally for oil pans, valve cap, valve timing cover. Very good quality. Made in Germany.



Art.No.	Quality	needed qty
20029	3	1



HYLOMAR engine sealing material, permanent elastic engine sealing, indispensable with engine overhaul, 80ml. Hylomar M is temperature resistant between -50°C and +250°C and can be applied for sealing surfaces and threaded pieces.



Art.No.	Quality	needed qty
20027	2	



Upholstery Cleaner, Deep cleaning foaming action, 500ml. Eliminates tough stains and soils like oil, grease and tar spots.



Art.No.	Quality	needed qty
21140	2	1



Section rubber adhesive + covering adhesives, in a brush box 350ml. Indispensable with work on one cover! Also premium for profile rubbers, full rubber, foam rubber, leather, lines, felt



Art.No.	Quality	needed qty
20492	2	1



The brake-down aid for on the road. SONAX TyreFix restores driveability to flat tyres, without tyre change. Seals small holes in the tyre and pumps it up. Practical, fast and safe. 400ml



Art.No.	Quality	needed qty
21024	3	1



Permanently elastic window sealant. Original Teroson! 75ml tube. Application : Ideal for sealing rubber-mounted front, rear and side windows. Very stable, water resistant, remains elastic. Good adhesion even on damp windcreens.



Art.No.	Quality	needed qty
20966	2	1



Vehicle Window sealant permanent elastic. Original Teroson! Cartouche 310ml. Application: Ideally to sealing rubber-mounted front. - Tail and side windows. Very stably, water-resistant, remains elastic. Good adhesion also on wet disk.



Art.No.	Quality	needed qty
20967	2	1



Tugalin is a high-performance glass cleaner with long-term effect. It effortlessly removes soot and nicotine residues, oil and grease films, grease, dust, fingerprints, insect stains and much more from glass and all smooth surfaces. The nanoparticles leave an invisible protective layer on the cleaned surfaces, which delays resoiling and makes the next cleaning easier. Tugalin is a very powerful glass cleaner whose easy handling and streak-free results quickly make it an indispensable aid in industry, commerce and the home. 1000ml spray bottle. Made in Germany



Art.No.	Quality	needed qty
20666	2	1



Universal spray WD40, rust remover corrosion protection, with water resistant characteristics, contact spray. 400ml.



Art.No.	Quality	needed qty
20085	1	



Valve grinding-in paste (engine valves in the cylinder head), 100ml box. The double box contains pre-grinding paste (rough) and regrinding paste (fine).



Art.No.	Quality	needed qty
20503	2	1



Screw-safety-paint, yellow, 20ml bottle including brush. This paint to be fit as sealing and marking paint and can be directly brought onto the spot which has to be marked. Standart product in the 60's for marking on gearboxes, engines, hydraulic parts and chassis parts



Art.No.	Quality	needed qty
21015	3	1



siliconepin with sponge, to rub in door rubbers etc. 100ml



Art.No.	Quality	needed qty
20210	3	



Silicone spray, 400ml. Manufacturer: SONAX. Silicone Spray is colourless. It displaces water and offers very good lubricating properties. It can be used for metal, rubber, plastic and even wood. It is ideal for creaking dashboards, for example. Lubricate sunroof guides, door side window guides, etc.



Art.No.	Quality	needed qty
20120	2	1



Spray adhesive, 500ml. Very useful for affixing of interior lining, damming mats, hoods etc. High adhesive. We have been searching for a long time since we found a really good one.



Art.No.	Quality	needed qty
20011	1	



Starting pilot, 200ml. Brings tired engines to running, e.g. after long holding time.



Art.No.	Quality	needed qty
20073	2	



Teufels-Reiniger® is a power cleaner with enormous dirt dissolving power. Oil and grease stains, nicotine, soot, insect carcasses and much more are no problem for this cleaner. Cleaning takes place automatically. The highly concentrated formula can be diluted with water and is therefore very economical. This cleaner has been specially developed for cleaning vehicles, trade and industry (also ideal for cleaning machines, engines, tools, workshop floors, etc.). 1000ml spray bottle. We only work with Teufels Reiniger. Our absolute recommendation. Made in Germany



Art.No.	Quality	needed qty
20970	2	1



1001 trim strips

1003 chrome parts

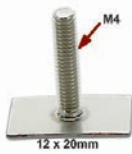

Clip for trim, strip screw:
12x20mm. Universal suitable.
Thread: M4 x 19mm. Made in
Germany.

Art.No.	Quality	needed qty
90629	3	



Sikaflex 221, 300ml, cartouche.
Adhesion-strong sealing
compound, for sealing sheet
metal overlaps (sheet metal
grooves). Color: black.
Overpaintable.

Art.No.	Quality	needed qty
20022	1	



Footboards on the left + on the
right, for the entrance (Robri).
Suitable for Citroën HY.
Produced from polished,
aluminum casting.

Art.No.	Quality	needed qty
48291	3	1



hub caps 1002



Wheel cover (hub cover, wheel
lid). Suitable for Citroën HY.
Made in Germany. A little thing,
but if the original caps are no
longer beautiful, adorn new
hub caps the complete vehicle.

Art.No.	Quality	needed qty
44908	3	4



Turn signals - Decorative rings
for the front turn signals (2
pieces), for Citroën 2CV. Also
suitable for the rear lights
Citroën AZU, AK400, DS Break,
HY, AMI6. Attention, the trim
rings only fit on lights of the manufacturer "AXO".
The Seima lamps are too flat. Own reproduction.
Anodised aluminium.

Art.No.	Quality	needed qty
16855	1	1



Autosol chrome polish. 75 ml
tube. (Premium chrome shine
care). Autosol chrome polish
has been around for ages and
has often been copied! Made in
Germany.

Art.No.	Quality	needed qty
20968	2	1



Citroën emblem (Chevron) on
the dashboard. Suitable for
Citroën 11CV + 15CV, up to year
of construction 02/1952. Or. No.
802594. Dimension: 38 x 40mm.
The emblem can also be used
universal.

Art.No.	Quality	needed qty
60160	3	1



Citroën angle (emblem), gold-
colored. Reproduction made of
metal. Or. No. D854-4

Art.No.	Quality	needed qty
37265	3	1

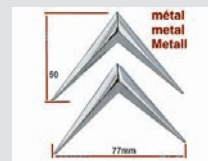

Citroën angle chromium-plates,
made of metal. Universal fitting.
2x brackets = 1x 16807!!
Reproduction

Art.No.	Quality	needed qty
16807	3	1



chrome parts 1003



License plate handle rear, made
of metal, anodizes. For license
plate 205x343mm. Suitable for
R4, Dauphine, Käfer etc. Outer
dimension: 365 x 255mm. Made
in Germany

Art.No.	Quality	needed qty
18905	1	1



M8 x 25 screws, with 20mm
head. The suitable for radiator
grill securement to Citroën
11CV. This screw can be also
universal used, for example
fasten from bumpers. Or. No.
331101

Art.No.	Quality	needed qty
60273	3	4



Retaining tie-clip for emblems.
Suitable for 3mm pins. Per
piece!

Art.No.	Quality	needed qty
16861	3	4



License plate handle made of
metal, anodizes. Suitable for all
license plates, who are 520mm
wide! Made in Germany

Art.No.	Quality	needed qty
18904	1	2



License plate handle from
chromium-plated synthetic.
Suitable for all license plates,
who are 520mm wide!

Art.No.	Quality	needed qty
18901	3	2



11

tools

special tools for motor vehicles	1102
tools generally	1103
screws + nuts	1104
electrical material generally	1105



Special-flarings for classic Citroen cars
For brake- and hydraulic-pipes
Also on hard-to-reach places.

Born from practical experience
Perfect for one-man handling
You save money and time

Steady or mobile use on the car.
In the workshop or for mobile service

Art. No.: **20074** (for Citroen)

Art. No.: **20938** (for Citroen and all others flaring)



Hydraulic line and brake line flaring tool

Made in Germany

Hydraulic line and brake line flaring tool for Citroen type tubes of the dimensions 3,5mm, 4,5mm + 6,35mm (1/4").

The great advantage of this tool is, that it can be used directly on the vehicle without having to use additional devices like pliers or a bench vice. This feature makes this tool unique in the whole world.





Exhaust pipe cutter, for 28 to 67mm diameter. The pipe cutter has a ratchet function. Cutting depth up to 3mm.



Art.No.	Quality	needed qty
20940	3	1



Exhaust pipe cutter: Cutting wheel as replacement for pipe cutter 20940



Art.No.	Quality	needed qty
20939	3	1



Exhaust tubing tool. For diameter 29 - 44mm. Only for tubing strengths upto max. 1,5mm. Not for high-grade steel pipes suitable. The exhaust pipe must be heated before processing! The tool must be introduced completely!



Art.No.	Quality	needed qty
21033	3	1



Exhaust tubing tool. For diameter 38 - 64mm. Only for tubing strengths upto max. 1,5mm. Not for high-grade steel pipes suitable. The exhaust pipe must be heated before processing! The tool must be introduced completely!



Art.No.	Quality	needed qty
21034	3	1



Autoskop, for the search for abnormal vibrations or liquid leakage. Delivery with one sensing head



Art.No.	Quality	needed qty
20092	3	1



Battery charger - trickle charger for winter storage (OptiMate 1). Switchable between 6 volts and 12 volts. This small continuous charger is ideal for permanently connecting to a battery during the winter break. State-of-the-art technology protects against reverse polarity of the connections. It is suitable for normal lead batteries (those with acid). The maximum charging current is 0.6 amps. Please note: You cannot use this charger to quickly charge or reactivate empty batteries! It is therefore designed to keep the battery fresh and, if necessary, charge it very slowly. The scope of delivery also includes a charging cable that can be permanently connected to the battery. Simply route the plug connection to the outside and the charger can be connected without opening the bonnet.



Art.No.	Quality	needed qty
20566	1	1



Battery charger for 12 volts (OptiMate 6 Ampmatic). Charging capacity: 6 amps. The 'Swiss Army knife' among battery chargers. You can connect all types of batteries (STD, AGM, EFB, GEL batteries). Almost all sizes can also be connected (3AH > 144Ah). This charger can even reactivate deeply discharged batteries (down to a discharge of 0.5 volts)! Its smart electronics make it possible. You can also test batteries. It has a safety circuit in case it is connected incorrectly. It controls the charging current according to the ambient temperature and has many other options. Whether it's a lawnmower, boat, car, motorhome, motorbike or tractor, this charger automatically adjusts to everything. And let's be honest, who knows what kind of battery is installed in modern vehicles these days? With this, it doesn't matter! Only modern electric vehicles cannot be charged with it! Of course, it can also be used as a normal battery maintenance charger. Our tip if you have several vehicles that are stored over the winter: get one of these chargers and equip the other vehicles with our maintenance chargers. The scope of delivery also includes a charging cable that can be permanently connected to the battery. Simply route the plug connection to the outside and the charger can be connected without opening the bonnet. Regular desulphation is important for a long service life of lead-acid batteries. And this is what these modern chargers can do.



Art.No.	Quality	needed qty
20567	1	1



Battery charger for 6 volts + 12 volts (OptiMate 5 6V/12V). Charging capacity: 3 amps at 12 volts. 4 amps at 6 volts. This battery charger and trickle charger only charges lead-acid batteries (i.e. the batteries in classic cars). It can be used for both 6 volt and 12 volt batteries. This charger can also reactivate deeply discharged batteries (up to a discharge of 0.5 volts)! The clever electronics make it possible. You can also test batteries. It has a fuse circuit in case it is connected incorrectly. It controls the charging current according to the ambient temperature and has many other options. Regular desulphation is important for a long battery service life. And this is what these modern chargers can do.



Art.No.	Quality	needed qty
20568	1	1



Battery terminals cleaning + milling cross. Indispensable for vintage cars! Trim once, and the electrical contact is back in order.



Art.No.	Quality	needed qty
20500	3	1



Mini Dent Puller. This mini suction puller its strong pulling power is ideal for minor car panel dents. 55mm diameter suction disc. Can be used in pairs if necessary provides strong pulling power.



Art.No.	Quality	needed qty
20507	1	1

1102 special tools for motor vehicles



Brake pipe bending pliers! Been suitable for sheet metal, copper, stealing and aluminum lines. Bends up to 90°. Suitable for pipe Ø: 3/16" (4,75mm), 1/4" (6,35mm), 5/16" (7,93mm), 3/8 (9,52mm).



Art.No.	Quality	needed qty
20974	3	1



Accelerator and Brake Pedal depressor. Convenient tool for one-man operations. For depressing the brake pedal, e.g. wheel alignment jobs, checking brake lights or trailer brakes. For depressing the accelerator, e.g. setting the engine speed or measuring omissions. 1 men operation. Finely adjustable, with high-speed release function!



Art.No.	Quality	needed qty
20983	3	1



Brakes bleeder device! Working pressure 5-8 bar, max. vacuum 60%, capacity 1L,



Art.No.	Quality	needed qty
20975	3	1



Brake spring pliers for drum brake. 215mm long. One end grips on the brake lining, the other hooks onto the spring



Art.No.	Quality	needed qty
21061	3	1



Brake line wrench. 10mm + 11mm. Workshop quality.



Art.No.	Quality	needed qty
20055	3	1



Brake line wrench. 8mm + 9mm. Workshop quality.



Art.No.	Quality	needed qty
20075	3	1



Brake drum wear gauge. Used to measure the wear limit on brake drums as well as to measure the diameter of the drum and then set the shoe position prior to drum re-fitting. Max size drums 400mm diameter. Brake drum wear gauge. Size range 160mm-400mm. Selected steel. Measures drum wear. Metric and Imperial scale



Art.No.	Quality	needed qty
21065	3	1



Drum spring draw hook from HAZET. Extremely helpfully.



Art.No.	Quality	needed qty
20515	2	1



Outside micrometer 0-25mm. Optimal for the actual dimension determination of kingpins.



Art.No.	Quality	needed qty
21165	3	1



CO tester (exhaust tester). Digitally. Optimally for the experienced mechanic, in order to adjust the carburetor. We use it since years for our classic cars! English operating instructions are attached. For the language German, Dutch, Spanish, Italian, French can be down-load the operating instructions of our homepage.



Art.No.	Quality	needed qty
20505	3	1



Crimping pliers for round plugs. Suitable for the uninsulated round plugs 3mm + 4mm. Brand quality KNIPEX



Art.No.	Quality	needed qty
21146	2	1



Roundings/minute-Indicator (laser). Very easy to use: just select a level and confirm to. Ideal for engine adjustment!



Art.No.	Quality	needed qty
21111	3	1



pressure spray gun cavity with hook and cavity nozzle, incl. pre-heating device for Mike Sander grease



Art.No.	Quality	needed qty
20083	3	1



Nozzle gauge from 0.45 to 1.5 mm. 20 nozzle gauges. With these nozzle gauges, you can determine the diameter of carburettor nozzles. Indispensable for work on the carburettor (e.g. changing the nozzle to original values, calibrating the carburettor, etc.).



Art.No.	Quality	needed qty
10914	3	1



Rivet nut assortment made of aluminium. Consisting of: 40x M3, 35x M4, 25x M5, 25x M6, 15x M8, 10x M10. Rivet nuts are ideal for creating a thread in sheet metal. A typical example is the mirror assembly on the doors or on the fenders (often the old threads are worn out or torn out). You will find the suitable riveting pliers under the number 21082.



Art.No.	Quality	needed qty
21083	3	1

special tools for motor vehicles 1102



Rivet nut pliers for M3, M4, M6, M8. With 2 lever arms (2 hand operation) for relatively easy insertion of rivets with optimum force transmission. You will find a suitable range of aluminium rivet nuts under our number 21083. Rivet nuts are ideally suited for creating a thread in sheet metal. A typical example is the mirror assembly on the doors or on the fenders (often the old threads are worn out or torn out).



Art.No.	Quality	needed qty
21082	3	1



Lock stamp "double Chevron". Height of 7mm. Optimal for mark from sheet metal parts.



Art.No.	Quality	needed qty
21062	3	1



Lubricating gun small, 120cc. Optimally for on the way and difficult attainable lubrication nipples!



Art.No.	Quality	needed qty
21050	3	1



Grease gun, for lubricating grease cartridge. Hobby quality!



Art.No.	Quality	needed qty
20047	4	1



Grease gun, for lubricating grease cartridge. Workshop quality from Liqui Moly!



Art.No.	Quality	needed qty
20563	2	1



Antifreeze Coolant Tester Dial Type



Art.No.	Quality	needed qty
20093	3	1



Universal Thread Gauge - 4pc. For individual gauges measuring pith and thread in Imperial, US and metric sizes. Identifies: bolts and spark plug from 10 to 18mm. Range 5/16 to 3/4, 10tpi - 44tpi, metric 2,5 - 22mm. Pitch 035 - 2,5mm.



Art.No.	Quality	needed qty
20509	1	1



sction pump (hand pump) for eG fuel, hydraulic liquid



Art.No.	Quality	needed qty
20481	3	1



Heli coil application M7. Length: 10,5mm (Thread repair)



Art.No.	Quality	needed qty
20179	2	1



Heli coil application M7. Length: 14,0mm (Thread repair)



Art.No.	Quality	needed qty
21135	2	1



Heli coil application M7. Length: 7,0mm (Thread repair)



Art.No.	Quality	needed qty
21134	2	1



Thread Repair Kit M7x1, for repairing damaged threads. For plating threads in materials with low shearing strength 1 twist drill, 1 tap, 1 installation tool, 1 tang breaker, 25 x M7x1 coil.



Art.No.	Quality	needed qty
20982	3	1



Helicoil repair set for M7. Consisting of: Twist drill (to M12), hand taps from HSS, mounting spindle, insertion pin breaker (to M12). In each case, 10 threaded inserts M7 in the lengths: 7,0mm, 10,5mm, 14,0mm. Original Helicoil, no reproduction.



Art.No.	Quality	needed qty
21136	2	1



Hone segment 100x10mm (3 fittings) for engine cylinder hone 20918.



Art.No.	Quality	needed qty
20921	2	1



Hone segment 30x4mm (2 fittings) for brake cylinder hone 20916.



Art.No.	Quality	needed qty
20919	3	1



Hydraulic line Brake line flaring tools for use at the vehicle (to use at the car). For all flanging! For all Citroën lines with 3,5mm, 4,5mm + 6,35mm (1/4"). For all lines after DIN/CSAE, for flanges of the types CD, E, F, F180 in the usual quantities 4,75mm, 6mm, 8mm, 9mm and 10mm.



Art.No.	Quality	needed qty
20938	1	1

1102 special tools for motor vehicles

1
2
3
4
5
6
7
8
9
10
11
12
13
14



Hog Rings (500 per pack) for 21048 automatic pliers (coverings). Suitable for Citroën, Peugeot, Renault. The suitable pliers have our number 21048.



Art.No.	Quality	needed qty
21049	1	1



Ratchet reduction. From 3/4 inch (socket wrench) on 1/2 inch (ratchet).



Art.No.	Quality	needed qty
20041	3	



piston ring presenting pliers for diameter 40-100.



Art.No.	Quality	needed qty
20099	3	1



Piston ring compressor, 60 to 90mm clamping range. Hobby version (not for daily work).



Art.No.	Quality	needed qty
20925	3	1



piston ring compressor from 60 up to 125mm, workshop quality (HAZET)



Art.No.	Quality	needed qty
20185	2	



Radiator Fin Straightener. Designed for straightening fins and removing debris from vehicles radiators and air conditioning condensers. One tool with 6 different combs works on any vent or grill. The use of this tool allows the radiator or air conditioning grill to work correctly. Also use on air conditioning grills. Also suitable for oil and water radiators/condensers and evaporators



Art.No.	Quality	needed qty
21039	1	1



Clutch pressure plate adjustment tool MR-3457-30. Suitable for Citroën HY, from year of construction 10/1968. This tool is for the height adjustment of the pressure plate. The pressure plate must be adjusted very accurately with each clutch assembly. Very important! See Citroën working instruction H312-3!



Art.No.	Quality	needed qty
48375	3	1



Clutch Alignment Tool, Universal. For single plate clutches. Suitable for flywheels with or without pilot bearing. Fast to fit and remove. Universal applications. Size of collets: 14mm to 28mm across 3 adaptors. Cone size range from 35mm < 67mm (for almost all classical french cars)



Art.No.	Quality	needed qty
20555	1	1



Box for clip band (Ligarex)



Art.No.	Quality	needed qty
20174	2	1



Ligarex strap, bellows clip strap of 50 meters. 5mm wide one.



Art.No.	Quality	needed qty
20219	2	



Ligarex strap, locks for the clip strap (100 fittings).



Art.No.	Quality	needed qty
20115	2	



Ligarex, specially pliers for clip strap (bellow straps). This securement was used at many French classic cars, for all kind of hose securement, like radiator hoses, collars, rubber bellows of the heating etc. With Ligarex you re-establish the original optics and you have always the suitable length in the workshop!



Art.No.	Quality	needed qty
20114	2	1



Ligarex strap, bellows clip strap of 25 meters, 5mm wide one.



Art.No.	Quality	needed qty
20116	2	



Drilling tool set in the wood stand. Equipped with ever drilling tools a 2mm, 3mm, 4mm, 5mm, 6mm, 7mm, 8mm, 9mm, 10mm.



Art.No.	Quality	needed qty
21124	3	1



Release lever set from synthetic for door linings, trim etc., 5 pieces





Art.No.	Quality	needed qty
20936	3	1

special tools for motor vehicles 1102





Magnetic lifter flexible + washing nozzles adjustment tool. This magnet lifter can be extended up to 592mm and is flexible at the end. Also the nut in the intake tract far behind is brought out with it again! Additionally it has a steel needle in the handle, with which washing nozzles can be adjusted.

Art.No.	Quality	needed qty
20963	1	1



Magnetic bowl, stainless steel bowl with magnetic base and soft rubber shell. Very useful to collect small parts! 150 mm diameter

Art.No.	Quality	needed qty
21121	3	1



Oil drain screw thread repair set for the following threads: M10x1.5, M12x1.5, M14x1.5, M16x1.5. 64 pieces. Scope of delivery: 4x tap drill, 5x plug screw for each thread size, 10x sealing ring for each thread size.

Art.No.	Quality	needed qty
20984	3	1

Oil absorbent pad. Extremely absorbent. Dimension: 51x38cm. For oils and brake fluids. Attention, the pads do not suck and absorb water! Your wife will be grateful!

Art.No.	Quality	needed qty
20511	1	1



Tool universal for oil filtre, fits for all oil filter, also to remove spheres!

Art.No.	Quality	needed qty
20216	2	

Hog Ring Pliers for use with A7 Hog Rings (Part No 21049). Complete with automatic feed. Ideal for continuous connections. Single handed operation. Ideal for upholstery on classic cars.

Art.No.	Quality	needed qty
21048	1	1

Hog ring plier for the mounting of coverings (workshop quality). With this pliers the hog ring's 18420 are optimally treated.

Art.No.	Quality	needed qty
18084	3	1





Wheel Stud Restorer Kit. For repairing damaged wheel stud threads using a reverse action to ensure the alignment of the thread. Includes adaptor sizes: M12 x 1.25mm. M12 x 1.5mm. M14 x 1.5mm.

Art.No.	Quality	needed qty
21047	1	1



Pipe cutting equipment for brake hoses!

Art.No.	Quality	needed qty
20942	3	1



Rust eraser pen. Ideal for removing even the smallest rust spots. Indispensable! And, of course, the cleaned rust spot must then be preserved with paint immediately.

Art.No.	Quality	needed qty
20032	1	1

Discs (windscreen) Pull-in tool (cord with handle). This is used to pull the rubber lip of the seal over the sheet metal fold. Very helpful!

Art.No.	Quality	needed qty
21114	3	1

Windscreens (windscreen) piping assembly tool - bracket inserts. For small piping. There are 5 brackets in different widths so that narrow and wide piping can be fitted (e.g. for the 2CV, R4...). Suitable for tool with item number 20134.

Art.No.	Quality	needed qty
20137	3	1





Windscreen Installation Tool Set. Windshield sealing trim assembly tool. With this tools will the rubber lip (seal) inclination (spread) and it can fit the sealing trim at the same time. Attention: The tool is for very wide piping. For chrome piping e.g. Citroën 2CV, Renault R4 etc. small brackets must be fitted. See our item number 20137.

Art.No.	Quality	needed qty
20134	1	1

Wiper nozzle cleaning and adjustment tool! Sturdy adjustment point, light cleaning stick. Both ends with end cap.

Art.No.	Quality	needed qty
20930	1	1



Spotweld drill, to rebore from spot welding!

Art.No.	Quality	needed qty
20119	3	



1102 special tools for motor vehicles

1
2
3
4
5
6
7
8
9
10
11
12
13
14



Trakrite Wheel Alignment Gauge. Trakrite is the simplest, most accurate device for checking the alignment of the steered wheels of car and light commercials. It is a roller bearing platform over which one front wheel is slowly driven with the wheels in their straight ahead position.



Art.No.	Quality	needed qty
20501	3	1



out turner for studs for 7mm bolts, profi quality of Facom



Art.No.	Quality	needed qty
20076	2	1



out turner of studs for 9mm bolts, profi quality of Facom



Art.No.	Quality	needed qty
20077	2	1



Stroboscope lamp ignition adjustment. Working place version! High quality!



Art.No.	Quality	needed qty
21109	3	1



Temperature indicator (laser), electronic, ideal for motor vehicle sector for instance to check on elbow wether all cylinders are working optimal or to check water temperature, etc. Very easy to use, good quality professional product!



Art.No.	Quality	needed qty
21110	3	1



Separation Fork Set, 5 pcs., forged carbon Steel 3 forks opening: 17,4 mm - 23,8 mm - 28,5 mm. 1 handle 200 mm long. 1 adapter for impact hammer 10 mm shaft-Ø, 175 mm long.



Art.No.	Quality	needed qty
20973	3	1



Transfer pump metal version, inclusive 2 hoses for drawing in and running off, 500ccm. Applicable for: Diesel, fuel oil, coolant, brake fluid.



Art.No.	Quality	needed qty
20922	3	1



Sealing paper set with and without metallic carrier! to produce own seals! Size DIN4. Original "REINZ".



Art.No.	Quality	needed qty
20206	3	1



Valve extractor + lifter (tire valve)



Art.No.	Quality	needed qty
20299	3	1



Valve grinder suction cup. 1x 16+21mm



Art.No.	Quality	needed qty
20561	3	1



Valve grinder suction cup. 1x 28+34mm



Art.No.	Quality	needed qty
20562	3	1



Valve grinding-in paste (engine valves in the cylinder head), 100ml box. The double box contains pre-grinding paste (rough) and regrinding paste (fine).



Art.No.	Quality	needed qty
20503	2	1



Valve clearance gauge. 0,05 > 1,00mm. Precision - feeler gauge with conical lamellas



Art.No.	Quality	needed qty
20045	3	1



universal valve spring compressor, for the development of the valves + valve springs.



Art.No.	Quality	needed qty
20095	3	1



Carburetor ring spanner, for the 12mm nut. Suitable for Citroën 11CV, HY, DS



Art.No.	Quality	needed qty
31319	3	1



Carburetor jet cleaning tool. Essential for carburetor maintenance and cleaning in your classic car. The scope of delivery includes five stainless steel nylon brushes with diameters of 2, 3, 4, 5 and 7 mm and a brush length of 30 mm. Ten stainless steel cleaning needles with diameters of 0.7, 0.9, 1.1, 1.3 and 1.4 mm. A 4 mm Allen key and twelve round carbon steel files with diameters of 0.4, 0.5, 0.6, 0.7, 0.8, 0.9, 1.0, 1.1, 1.2, 1.3, 1.4 and 1.6 mm. A flat file is also included.



Art.No.	Quality	needed qty
10915	3	1



Tool for the ball pin down (front axle). Citroën No: 1855-T. Suitable for Citroën HY + 15CV.



Art.No.	Quality	needed qty
44919	3	1



Flexible Spark Plug Remover/Installer. This specially designed tool allows access to spark plugs where they are deep seated or require off-line access. The tool is also designed to grip the spark plug securely allowing the removal with ease.



Art.No.	Quality	needed qty
21046	1	1



Heli coil spark plug thread repair set. For all M14 spark plugs. Contents: 1 bore + cutting tool, installation spindle. 10x heli coil insert M14x1,25x17,5. (Spark plugs with long threads). 10x heli coil insert M14x1,25x12,7. (Spark plugs with short threads, 2CV, R4).



Art.No.	Quality	needed qty
20947	2	1



Spark plug thread Helicoil insert. M14x1,25x12,7 (spark plugs with short thread 2CV, R4). Refill package (10 pieces)!



Art.No.	Quality	needed qty
20948	2	1



Spark plug thread M14 thread inserts. Suitable for our repair kit 21176. Length of thread inserts: 9.7 mm + 11.0 mm + 13.0 mm + 19.1 mm.



Art.No.	Quality	needed qty
21177	4	1



Spark plug thread M14 cleaner, with a cutter for the spark plug sealing ring. This combination tool can clean your contaminated thread and make it usable again. In addition, the sealing surface around the thread is nicely planed again. But be careful: if the spark plug thread is already badly damaged, you will need to insert a new thread (item 21176).



Art.No.	Quality	needed qty
21178	4	1



Spark plug thread M14 repair kit (for repairing defective spark plug threads). Hobby quality. For all M14 spark plugs. The repair kit comes with an HSS thread cutter (drive wrench size 17 mm) and 4 thread inserts. Length of thread inserts: 9.7 mm + 11.0 mm + 13.0 mm + 19.1 mm.



Art.No.	Quality	needed qty
21176	4	1



Spark plug wrench (adjustable in length), for 20,8mm spark plugs. This key is perfect for the Citroën DS. It can be used with the normal electrode extension. Fitting for 3/8 inch ratchet (medium size). Fits of course also on all other spark plugs, for 21mm tools. Manufacturer: HAZET. Adjustable length from: 137,5mm to 157,5mm and 195,5mm. With spark plug holding rubber.



Art.No.	Quality	needed qty
21076	1	1



Spark plug wrench (tube wrench), for 20.8 mm spark plugs. 300mm long! Particularly for Citroën DS, Peugeot 203, 403, 404, 504. Workshop quality!



Art.No.	Quality	needed qty
20094	2	1

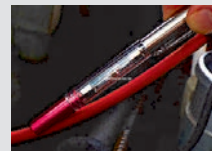

Spark Indicator. This non-contact spark tester will test for the presence of power in spark plugs, coils and distributors. Simply place the grooved end over the spark plug wire with the engine running and the high intensity bulb will flash indicating spark. Note: Depending upon screen of the ignition cables, it can be possible, that you see the flashing by daylight, very bad!



Art.No.	Quality	needed qty
20506	1	1



Brake cylinder hone. For use with a cordless drill to clean brake cylinders during service. 22-69mm. For honing out brake cylinders. For use with a standard drill.



Art.No.	Quality	needed qty
20916	3	1



Engine cylinder hone. Enables the inside surface of the cylinders to be cleaned of carbon deposits etc. Suitable for all cylinders with a bore diameter of 50



Art.No.	Quality	needed qty
20918	3	1



1103 tools generally

1
2
3
4
5
6
7
8
9
10
11
12
13
14



Torque wrench largely, 40-200Nm. 1/2 " mounting. Professional quality



Art.No.	Quality	needed qty
20903	3	1



Torque wrench small, 5-25Nm. 1/4 " mounting. Only for screws with right-hand thread suitably (torsion in in the clockwise direction).



Art.No.	Quality	needed qty
20904	3	1



Rivet nut pliers for M3, M4, M6, M8. With 2 lever arms (2 hand operation) for relatively easy insertion of rivets with optimum force transmission. You will find a suitable range of aluminium rivet nuts under our number 21083. Rivet nuts are ideally suited for creating a thread in sheet metal. A typical example is the mirror assembly on the doors or on the fenders (often the old threads are worn out or torn out).



Art.No.	Quality	needed qty
21082	3	1



Tap drill M10x1. (M10x1 was very often used with brake hoses). Manual cut tap drill!



Art.No.	Quality	needed qty
20944	3	1



Manual cut tap drill M11x1



Art.No.	Quality	needed qty
20945	3	1



Thread tap M7 x 1,00. Hobby quality



Art.No.	Quality	needed qty
21147	4	1



thread tap M7x1,00 DIN 352 HSS, top quality



Art.No.	Quality	needed qty
20132	3	1



thread drilling M9 x 1,00



Art.No.	Quality	needed qty
20220	3	1



Thread tap M9 x 1,25. Hobby quality



Art.No.	Quality	needed qty
21148	4	1



Screw gauge metric + Whitworth. Angle of pressure 60° with 24 upward gradients 0,25-6mm. Angle of pressure 55° with upward gradients 4-62 gear on 1 ".



Art.No.	Quality	needed qty
20906	3	1



Hook set, 135 mm long. 4 pieces, ideal for removing O-rings, seals, Citroën brake line seals, etc. Contents: 1x straight tip, 1x 90° tip, 1x hook tip, 1x piercing tool.



Art.No.	Quality	needed qty
20902	3	1



Ratchet adapter (enlargement). From 1/4 ratchet to 3/8 socket wrench.



Art.No.	Quality	needed qty
21052	3	1



Ratchet adapter (enlargement). From 3/8 ratchet to 1/2 socket wrench.



Art.No.	Quality	needed qty
21053	3	1



M11x1 male thread cutter (die nut). Workshop quality. E.G. suitable for the spring pot hinged tie bars threads of Citroën 2CV.



Art.No.	Quality	needed qty
20228	3	1



M7 die nut (male thread cutter). Lead of thread 0,75. Workshop quality



Art.No.	Quality	needed qty
20188	3	1



M7 x 1,00 male thread cutter (die nut M9x1,25)



Art.No.	Quality	needed qty
21150	4	1



M9 x 1,25 male thread cutter (die nut M9x1,25)



Art.No.	Quality	needed qty
21149	4	1



Open-end spanner - ring spanner set (8 pieces) for inch thread (1/8 - 9/16 Withworth). Many brake parts on French classic cars often have an inch thread!



Art.No.	Quality	needed qty
20558	3	1



Multimeter digital. Dimension: 74x145x40mm. Measuring range: Volt direct current + alternating current. Ampere, resistance, continuity tester. Everything what you need, for car electrical connection.



Art.No.	Quality	needed qty
20147	1	1



Steering rod separating fork, workshop quality



Art.No.	Quality	needed qty
20125	3	1



Oil can with pump, made of sheet metal, blue painted, optic like in former times, 125 ccm content,



Art.No.	Quality	needed qty
20088	3	1



Underbody coating nozzle (gun) + cavity preservation nozzle (gun), for 1 liter of doses, very high quality.



Art.No.	Quality	needed qty
20123	3	1



6 - 24 Volt

Test lamp for car, 6-24 V.



Art.No.	Quality	needed qty
20126	3	1



First aid kit Compact, according to DIN 13164. Length: 215mm. Wide one: 55mm. Amount: 130mm. Original LEINA!



Art.No.	Quality	needed qty
20049	2	1



Scrapers professional version, to remove of labels on disks, engine sealing remainders scrape etc. off.



Art.No.	Quality	needed qty
20484	3	1



Scraper spare blades for 20484 (5 St)



Art.No.	Quality	needed qty
20912	3	1



5 KG

Soda, blasting abrasive, 5KG jerrycan, suitable for our mineralic blast gun 21155.



Art.No.	Quality	needed qty
21156	3	1



Sodium carbonate (Soda) blast gun. Washing soda is an effective procedure to remove paint and surface rust without harming the support material. It don't cause any damage of rubber, glas or plastic, so a complicated covering is not necessary. In opposite to sandblast, Soda protects the cleaned material against rust at once. Environment friendly and gently removal from different coatings on boats, wooden furniture, glas and window frames is possible. This blast gun is not suitable for sandblast usage. Operating pressure is 87-174 lbs. Minimum air consumption is 180 liter/minute at 120 lbs.



Art.No.	Quality	needed qty
21155	3	1



Mirror flexibly, with joint. 360mm lengthens. Mirror diameter 30mm.



Art.No.	Quality	needed qty
20091	3	1



Spark gap measurement (testing) tool. With the help of this small, inexpensive tool, the spark gap of the spark plug can be checked very easily and safely. So, if the engine does not start: Is the spark plug sparking at all! And if so, how strong! Then exclusion procedure: Ignition OK? It is not getting any petrol!



Art.No.	Quality	needed qty
20559	3	1

M14 x 1,25



Tap drill M14x1,25. (Spark plug threads).



Art.No.	Quality	needed qty
20946	3	1



1104 screws + nuts

1
2
3
4
5
6
7
8
9
10
11
12
13
14



Fender rear, screw from high-grade steel (round head M5x16).



Art.No.	Quality	needed qty
20145	1	



Sheet metal driving screw with large head, black galvanizes. Measurements: 3,5 x 16mm.



Art.No.	Quality	needed qty
20169	3	



Soft top hood, push-button completely, for riveting. Universal fitting.



Art.No.	Quality	needed qty
17115	2	



Sheet metal driving screw with large head, black galvanizes. Measurements: 4.2 x 19 mm.



Art.No.	Quality	needed qty
20170	3	



Sheet metal nut, 2,9. For sheet metal driving screw with 2,9mm core diameter. Dimension: 12.0 x 11,0mm.



Art.No.	Quality	needed qty
20545	3	



Rivet nut assortment made of aluminium. Consisting of: 40x M3, 35x M4, 25x M5, 25x M6, 15x M8, 10x M10. Rivet nuts are ideal for creating a thread in sheet metal. A typical example is the mirror assembly on the doors or on the fenders (often the old threads are worn out or torn out). You will find the suitable riveting pliers under the number 21082.



Art.No.	Quality	needed qty
21083	3	1

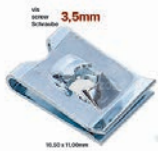

Sheet metal nut, 3,5. For sheet metal driving screw with 3,5mm core diameter. Dimension: 16,50 x 11,0mm.



Art.No.	Quality	needed qty
20546	3	



Spring Assortment, 200 pcs. Compression and extension springs, popular sizes



Art.No.	Quality	needed qty
20977	3	1



Sheet metal nut, 3,9. For sheet metal driving screw with 3,9mm core diameter. Dimension: 16,50 x 11,30mm.



Art.No.	Quality	needed qty
20547	3	



R-Clip Assortment, 150 pcs. 6 popular sizes, 2,4 x 31 mm, 2,0 x 33 mm, 2,0 x 40 mm, 2,8 x 42 mm, 3,5 x 45 mm, 4,0 x 75 mm.



Art.No.	Quality	needed qty
20976	3	1



Sheet metal nut, 4,2. For sheet metal driving screw with 4,2mm core diameter. Dimension: 16,50 x 11,20mm.



Art.No.	Quality	needed qty
20544	3	



Screw gauge metric + Whitworth. Angle of pressure 60° with 24 upward gradients 0,25-6mm. Angle of pressure 55° with upward gradients 4-62 gear on 1".



Art.No.	Quality	needed qty
20906	3	1



Sheet metal nut, 4,8. For sheet metal driving screw with 4,8mm core diameter. Dimension: 16,50 x 14,50mm.



Art.No.	Quality	needed qty
20548	3	



Clamp made of metal, for up to 10mm lines. (Cable harness, gasoline line, water hose etc.). The clip can be inserted on each sheet metal seam up to the maximum strength by 2mm.



Art.No.	Quality	needed qty
20502	3	5



Universal Thread Gauge - 4pc. For individual gauges measuring pith and thread in Imperial, US and metric sizes. Identifies: bolts and spark plug from 10 to 18mm. Range 5/16 to 3/4, 10tpi - 44tpi, metric 2,5 - 22mm. Pitch 035 - 2,5mm.



Art.No.	Quality	needed qty
20509	1	1



Fixing clamp for screwing on (for max. 9mm cables). Fixing hole in the clamp: 4.8mm. (e.g. for fuel hoses, hydraulic hoses, wiring harness...)



Art.No.	Quality	needed qty
37952	3	



Rubber silent block M10. Diameter: 40mm. Overall height: 28mm. Suitable for Renault R16 and many different.



Art.No.	Quality	needed qty
82825	3	2

NEW!



Art.No. 82020 Quality 3 needed qty 1



Art.No. 82990 Quality 3 needed qty 1



Art.No. 20179 Quality 2 needed qty 2



Art.No. 21135 Quality 2 needed qty 2



Art.No. 21134 Quality 2 needed qty 2



Art.No. 21136 Quality 2 needed qty 1



Art.No. 20979 Quality 3 needed qty 1



Art.No. 60339 Quality 3 needed qty 1



Art.No. 20287 Quality 3 needed qty 1



Art.No. 21063 Quality 3 needed qty 3



Art.No. 20995 Quality 3 needed qty 3



Art.No. 20999 Quality 3 needed qty 3



Art.No. 10592 Quality 3 needed qty 3



Art.No. 21027 Quality 3 needed qty 1



Art.No. 20026 Quality 2 needed qty 1



Art.No. 19035 Quality 2 needed qty 2



Art.No. 19033 Quality 2 needed qty 2



Art.No. 19034 Quality 2 needed qty 2



1104 screws + nuts

1
2
3
4
5
6
7
8
9
10
11
12
13
14

 <p>M10</p>	<p>spring washer M10, galvanized</p> <table border="1"> <tr> <th>Art.No.</th> <th>Quality</th> <th>needed qty</th> </tr> <tr> <td>20268</td> <td>3</td> <td></td> </tr> </table>	Art.No.	Quality	needed qty	20268	3			 <p>M4</p>	<p>Nut M4 galvanized</p> <table border="1"> <tr> <th>Art.No.</th> <th>Quality</th> <th>needed qty</th> </tr> <tr> <td>20165</td> <td>3</td> <td></td> </tr> </table>	Art.No.	Quality	needed qty	20165	3		
Art.No.	Quality	needed qty															
20268	3																
Art.No.	Quality	needed qty															
20165	3																
 <p>M10</p>	<p>Nut M10, galvanized</p> <table border="1"> <tr> <th>Art.No.</th> <th>Quality</th> <th>needed qty</th> </tr> <tr> <td>20175</td> <td>3</td> <td></td> </tr> </table>	Art.No.	Quality	needed qty	20175	3			 <p>M4x10</p>	<p>Screw M4x10 / machine screw</p> <table border="1"> <tr> <th>Art.No.</th> <th>Quality</th> <th>needed qty</th> </tr> <tr> <td>20488</td> <td>3</td> <td></td> </tr> </table>	Art.No.	Quality	needed qty	20488	3		
Art.No.	Quality	needed qty															
20175	3																
Art.No.	Quality	needed qty															
20488	3																
 <p>M10x1</p>	<p>Nut M10x1. Flat design. For fastening brake hoses.</p> <table border="1"> <tr> <th>Art.No.</th> <th>Quality</th> <th>needed qty</th> </tr> <tr> <td>21036</td> <td>3</td> <td></td> </tr> </table>	Art.No.	Quality	needed qty	21036	3			 <p>M4 x 12</p>	<p>screw M4x12, galvanized (machine screw)</p> <table border="1"> <tr> <th>Art.No.</th> <th>Quality</th> <th>needed qty</th> </tr> <tr> <td>20269</td> <td>3</td> <td></td> </tr> </table>	Art.No.	Quality	needed qty	20269	3		
Art.No.	Quality	needed qty															
21036	3																
Art.No.	Quality	needed qty															
20269	3																
 <p>M10x70</p>	<p>Screw M10x70</p> <table border="1"> <tr> <th>Art.No.</th> <th>Quality</th> <th>needed qty</th> </tr> <tr> <td>20205</td> <td>3</td> <td></td> </tr> </table>	Art.No.	Quality	needed qty	20205	3			 <p>M5</p>	<p>M5, cover for bolt head</p> <table border="1"> <tr> <th>Art.No.</th> <th>Quality</th> <th>needed qty</th> </tr> <tr> <td>20494</td> <td>3</td> <td></td> </tr> </table>	Art.No.	Quality	needed qty	20494	3		
Art.No.	Quality	needed qty															
20205	3																
Art.No.	Quality	needed qty															
20494	3																
 <p>M12</p>	<p>Spring washer M12</p> <table border="1"> <tr> <th>Art.No.</th> <th>Quality</th> <th>needed qty</th> </tr> <tr> <td>20131</td> <td>1</td> <td></td> </tr> </table>	Art.No.	Quality	needed qty	20131	1			 <p>M5</p>	<p>M5 weld nut (spot weld nut), like original! Suitable for Citroen 2CV, DS, HY</p> <table border="1"> <tr> <th>Art.No.</th> <th>Quality</th> <th>needed qty</th> </tr> <tr> <td>21081</td> <td>3</td> <td></td> </tr> </table>	Art.No.	Quality	needed qty	21081	3		
Art.No.	Quality	needed qty															
20131	1																
Art.No.	Quality	needed qty															
21081	3																
 <p>12x23,5 Inox</p>	<p>Washer Stainless steel M12</p> <table border="1"> <tr> <th>Art.No.</th> <th>Quality</th> <th>needed qty</th> </tr> <tr> <td>20130</td> <td>3</td> <td></td> </tr> </table>	Art.No.	Quality	needed qty	20130	3			 <p>M5</p>	<p>Nut M5, galvanized</p> <table border="1"> <tr> <th>Art.No.</th> <th>Quality</th> <th>needed qty</th> </tr> <tr> <td>20163</td> <td>3</td> <td></td> </tr> </table>	Art.No.	Quality	needed qty	20163	3		
Art.No.	Quality	needed qty															
20130	3																
Art.No.	Quality	needed qty															
20163	3																
 <p>M12x1,5</p>	<p>Nut selflocking M12 x 1,5.</p> <table border="1"> <tr> <th>Art.No.</th> <th>Quality</th> <th>needed qty</th> </tr> <tr> <td>73606</td> <td>3</td> <td></td> </tr> </table>	Art.No.	Quality	needed qty	73606	3			 <p>M5 x 12 striees 60x</p>	<p>Washer corrugated M5x12 (French name: Striees). Content: 60 units. These grooved washers were original Installed at French vehicles!</p> <table border="1"> <tr> <th>Art.No.</th> <th>Quality</th> <th>needed qty</th> </tr> <tr> <td>20271</td> <td>2</td> <td>1</td> </tr> </table>	Art.No.	Quality	needed qty	20271	2	1	
Art.No.	Quality	needed qty															
73606	3																
Art.No.	Quality	needed qty															
20271	2	1															
 <p>M12x1,5</p>	<p>Nut M12x1,5. Flat design. For fastening brake hoses.</p> <table border="1"> <tr> <th>Art.No.</th> <th>Quality</th> <th>needed qty</th> </tr> <tr> <td>21037</td> <td>3</td> <td></td> </tr> </table>	Art.No.	Quality	needed qty	21037	3			 <p>M5 x 16 striees 60x</p>	<p>Washer corrugated M5x16 (French name: Striees). Content: 60 units. These grooved washers were original Installed at French vehicles!</p> <table border="1"> <tr> <th>Art.No.</th> <th>Quality</th> <th>needed qty</th> </tr> <tr> <td>20272</td> <td>2</td> <td>1</td> </tr> </table>	Art.No.	Quality	needed qty	20272	2	1	
Art.No.	Quality	needed qty															
21037	3																
Art.No.	Quality	needed qty															
20272	2	1															
 <p>M3</p>	<p>Nut M3 galvanized (chrome trim ventilation shutter)</p> <table border="1"> <tr> <th>Art.No.</th> <th>Quality</th> <th>needed qty</th> </tr> <tr> <td>20166</td> <td>3</td> <td></td> </tr> </table>	Art.No.	Quality	needed qty	20166	3				<p>Washer set original Citroën "Strie". Contents: M5x12, M5x16, M6x14, M6x18, M7x14, M7x18, M8x18, M8x22. Range with 480 units, for all Citroën, Peugeot and Renault.</p> <table border="1"> <tr> <th>Art.No.</th> <th>Quality</th> <th>needed qty</th> </tr> <tr> <td>20213</td> <td>1</td> <td>1</td> </tr> </table>	Art.No.	Quality	needed qty	20213	1	1	
Art.No.	Quality	needed qty															
20166	3																
Art.No.	Quality	needed qty															
20213	1	1															

<p>M5x10</p>	<p>M5x10, screw galvanizes.</p>							
<table border="1"> <thead> <tr> <th>Art.No.</th> <th>Quality</th> <th>needed qty</th> </tr> </thead> <tbody> <tr> <td>21126</td> <td>3</td> <td></td> </tr> </tbody> </table>	Art.No.	Quality	needed qty	21126	3			
Art.No.	Quality	needed qty						
21126	3							
	<p>M5x16/screw from high-grade steel (1 piece)</p>							
<table border="1"> <thead> <tr> <th>Art.No.</th> <th>Quality</th> <th>needed qty</th> </tr> </thead> <tbody> <tr> <td>20296</td> <td>1</td> <td></td> </tr> </tbody> </table>	Art.No.	Quality	needed qty	20296	1			
Art.No.	Quality	needed qty						
20296	1							
<p>M5x16</p>	<p>Screw M5x16, galvanized</p>							
<table border="1"> <thead> <tr> <th>Art.No.</th> <th>Quality</th> <th>needed qty</th> </tr> </thead> <tbody> <tr> <td>20113</td> <td>3</td> <td></td> </tr> </tbody> </table>	Art.No.	Quality	needed qty	20113	3			
Art.No.	Quality	needed qty						
20113	3							
<p>M5x20</p>	<p>M5x20, screw galvanizes.</p>							
<table border="1"> <thead> <tr> <th>Art.No.</th> <th>Quality</th> <th>needed qty</th> </tr> </thead> <tbody> <tr> <td>21112</td> <td>3</td> <td></td> </tr> </tbody> </table>	Art.No.	Quality	needed qty	21112	3			
Art.No.	Quality	needed qty						
21112	3							
<p>M5 x 20</p>	<p>M5x20, pitch 0,75! Screw stainless steel. Note: This screw has a 0.75 pitch, as it was originally installed from Citroën, at the beginning of the seventies (S.i.m). Today's screws have 0,80 pitch! (ISO)</p>							
<table border="1"> <thead> <tr> <th>Art.No.</th> <th>Quality</th> <th>needed qty</th> </tr> </thead> <tbody> <tr> <td>21132</td> <td>1</td> <td></td> </tr> </tbody> </table>	Art.No.	Quality	needed qty	21132	1			
Art.No.	Quality	needed qty						
21132	1							
<p>M6</p>	<p>spring washer M6 galvanized</p>							
<table border="1"> <thead> <tr> <th>Art.No.</th> <th>Quality</th> <th>needed qty</th> </tr> </thead> <tbody> <tr> <td>20267</td> <td>3</td> <td></td> </tr> </tbody> </table>	Art.No.	Quality	needed qty	20267	3			
Art.No.	Quality	needed qty						
20267	3							
<p>M6</p>	<p>Nut M6, galvanized</p>							
<table border="1"> <thead> <tr> <th>Art.No.</th> <th>Quality</th> <th>needed qty</th> </tr> </thead> <tbody> <tr> <td>20159</td> <td>3</td> <td></td> </tr> </tbody> </table>	Art.No.	Quality	needed qty	20159	3			
Art.No.	Quality	needed qty						
20159	3							
<p>M6</p>	<p>washer M6, galvanized</p>							
<table border="1"> <thead> <tr> <th>Art.No.</th> <th>Quality</th> <th>needed qty</th> </tr> </thead> <tbody> <tr> <td>20270</td> <td>3</td> <td></td> </tr> </tbody> </table>	Art.No.	Quality	needed qty	20270	3			
Art.No.	Quality	needed qty						
20270	3							
<p>M6 x 14</p>	<p>Washers corrugated M6x14 (French name: Striées). Content: 70 units. These grooved washers were original Installed at French vehicles!</p>							
<table border="1"> <thead> <tr> <th>Art.No.</th> <th>Quality</th> <th>needed qty</th> </tr> </thead> <tbody> <tr> <td>20273</td> <td>2</td> <td>1</td> </tr> </tbody> </table>	Art.No.	Quality	needed qty	20273	2	1		
Art.No.	Quality	needed qty						
20273	2	1						

<p>M6 x 18</p>	<p>Washers corrugated M6x18 (French name: Striées). Content: 45 units. These grooved washers were original Installed at French vehicles!</p>							
<table border="1"> <thead> <tr> <th>Art.No.</th> <th>Quality</th> <th>needed qty</th> </tr> </thead> <tbody> <tr> <td>20274</td> <td>2</td> <td>1</td> </tr> </tbody> </table>	Art.No.	Quality	needed qty	20274	2	1		
Art.No.	Quality	needed qty						
20274	2	1						
<p>M6 x 10</p>	<p>M6x10 / screw galvanizes. For the securement of wheel brake cylinder.</p>							
<table border="1"> <thead> <tr> <th>Art.No.</th> <th>Quality</th> <th>needed qty</th> </tr> </thead> <tbody> <tr> <td>20160</td> <td>3</td> <td>4</td> </tr> </tbody> </table>	Art.No.	Quality	needed qty	20160	3	4		
Art.No.	Quality	needed qty						
20160	3	4						
<p>M6x20</p>	<p>Screw M6x20, galvanized</p>							
<table border="1"> <thead> <tr> <th>Art.No.</th> <th>Quality</th> <th>needed qty</th> </tr> </thead> <tbody> <tr> <td>20173</td> <td>3</td> <td></td> </tr> </tbody> </table>	Art.No.	Quality	needed qty	20173	3			
Art.No.	Quality	needed qty						
20173	3							
<p>M6x30</p>	<p>Screw galvanized M6x30</p>							
<table border="1"> <thead> <tr> <th>Art.No.</th> <th>Quality</th> <th>needed qty</th> </tr> </thead> <tbody> <tr> <td>20171</td> <td>3</td> <td></td> </tr> </tbody> </table>	Art.No.	Quality	needed qty	20171	3			
Art.No.	Quality	needed qty						
20171	3							
<p>M6x70</p>	<p>screw M6x70, galvanized</p>							
<table border="1"> <thead> <tr> <th>Art.No.</th> <th>Quality</th> <th>needed qty</th> </tr> </thead> <tbody> <tr> <td>20266</td> <td>3</td> <td></td> </tr> </tbody> </table>	Art.No.	Quality	needed qty	20266	3			
Art.No.	Quality	needed qty						
20266	3							
<p>M7</p>	<p>Box nut M7 (casing nut 14 x 14mm). Suitable for Citroën 2CV (in front at the original chassis. Fixture head light bracket - bumper mounting bracket)</p>							
<table border="1"> <thead> <tr> <th>Art.No.</th> <th>Quality</th> <th>needed qty</th> </tr> </thead> <tbody> <tr> <td>21057</td> <td>3</td> <td>2</td> </tr> </tbody> </table>	Art.No.	Quality	needed qty	21057	3	2		
Art.No.	Quality	needed qty						
21057	3	2						
<p>M7</p>	<p>M7, cover for bolt heath.</p>							
<table border="1"> <thead> <tr> <th>Art.No.</th> <th>Quality</th> <th>needed qty</th> </tr> </thead> <tbody> <tr> <td>20497</td> <td>3</td> <td></td> </tr> </tbody> </table>	Art.No.	Quality	needed qty	20497	3			
Art.No.	Quality	needed qty						
20497	3							
<p>M7</p>	<p>M7 welding nut (DIN929). Per piece</p>							
<table border="1"> <thead> <tr> <th>Art.No.</th> <th>Quality</th> <th>needed qty</th> </tr> </thead> <tbody> <tr> <td>21055</td> <td>3</td> <td></td> </tr> </tbody> </table>	Art.No.	Quality	needed qty	21055	3			
Art.No.	Quality	needed qty						
21055	3							
<p>M7</p>	<p>M7 weld nut (spot weld nut), like original! Suitable for Ctroen 2CV, DS, HY</p>							
<table border="1"> <thead> <tr> <th>Art.No.</th> <th>Quality</th> <th>needed qty</th> </tr> </thead> <tbody> <tr> <td>21080</td> <td>3</td> <td></td> </tr> </tbody> </table>	Art.No.	Quality	needed qty	21080	3			
Art.No.	Quality	needed qty						
21080	3							

- 1
- 2
- 3
- 4
- 5
- 6
- 7
- 8
- 9
- 10
- 11
- 12
- 13
- 14

1104 screws + nuts

1
2
3
4
5
6
7
8
9
10
11
12
13
14

M7 Spring washer M7 high-grade steel



Art.No.	Quality	needed qty
20151	3	

M7 Spring washer M7





Art.No.	Quality	needed qty
20111	3	

M7 copper nut M7 for exhaust system ! For exhaust system and outlet manifold. Please use only copper nuts: no rust, no sticking!



Art.No.	Quality	needed qty
20139	2	

M7 Brass nut, M7! DIN 934.



Art.No.	Quality	needed qty
20986	3	

M7 Nut, high-grade steel, M7



Art.No.	Quality	needed qty
20150	3	

M7 Nut M7, galvanized

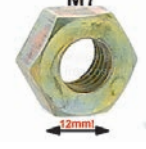

Art.No.	Quality	needed qty
20108	3	

M7 Nut M7, galvanised, 12mm wrench size!



Art.No.	Quality	needed qty
21011	3	

M7 Self-locking nut M7



Art.No.	Quality	needed qty
20110	3	

M7 M7, self-locking nut, yellow galvanised!



Art.No.	Quality	needed qty
20668	3	

M7 Washer, M7



Art.No.	Quality	needed qty
20106	3	

M7 M7, washer largely, 7,5x22mm, 2mm heavily.

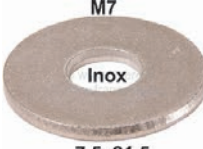

Art.No.	Quality	needed qty
20107	3	

M7 M7, washer largely, from high-grade steel, 7,5x21,5mm, 2mm heavily.



Art.No.	Quality	needed qty
20157	1	

M7 washer, diameter 50mm. For the securement of the body on the tank bow. Suitable for Citroën 2CV. Made in Germany.



Art.No.	Quality	needed qty
20140	2	2

M7 x 14 Washers corrugated M7x14 (French name: Striees). Content: 70 units. These grooved washers were original Installed at French vehicles!



Art.No.	Quality	needed qty
20275	2	1

7x14 Washer corrugated M7x14 (French name: Striees). Content: 1 piece. These grooved washers were original Installed at French vehicles!



Art.No.	Quality	needed qty
20783	2	

M7 x 18 Washer corrugated M7x18 (French name: Striees). Content: 45 units. These grooved washers were original Installed at French vehicles!

Art.No.	Quality	needed qty
20276	2	1

7x18 Washer corrugated M7x18 (French name: Striees). Content: 1 piece. These grooved washers were original Installed at French vehicles!

Art.No.	Quality	needed qty
20784	2	

M7 Toothed washer M7 galvanized

Art.No.	Quality	needed qty
20168	3	



M7x100, 8.8 / screw galvanizes.



Art.No.	Quality	needed qty
20514	3	



Screw M7x12, e.g. to fix the steeringwheel 2cv, screw is galvanized



Art.No.	Quality	needed qty
20164	3	3



Slotted counter-sunk screw M7x12.



Art.No.	Quality	needed qty
20282	4	



M7x12. Countersunk screw 7mm, with flat bolt head! Material: High-grade steel. The bolt head has about 12mm diameter! E.G. suitable for the door lock wedges (Citroën 11CV).



Art.No.	Quality	needed qty
60575	1	24



Screw Torx, M7x16. Content: 30 units.



Art.No.	Quality	needed qty
20279	2	



Screw M7x16 galvanized



Art.No.	Quality	needed qty
20101	3	



M7x17, female hexagon screw M7x17mm.



Art.No.	Quality	needed qty
21023	3	1



Slotted counter-sunk screw M7x20.



Art.No.	Quality	needed qty
20281	4	



Screw M7x20, galvanized



Art.No.	Quality	needed qty
20102	3	



M7x25 / screw high-grade steel, hexagonal 12mm. Flat bolt head



Art.No.	Quality	needed qty
20146	1	



Screw M7x25.



Art.No.	Quality	needed qty
12146	3	



Screw M7x30, galvanized



Art.No.	Quality	needed qty
20103	3	



Screw M7x35



Art.No.	Quality	needed qty
20233	3	



Screw M7x40, galvanized, to fix the gearbox holder on front axle



Art.No.	Quality	needed qty
20104	3	



Screw M7x45



Art.No.	Quality	needed qty
20234	3	



M7x50 / screw with shaft. E.g. fastening steering column to steering gear on Citroën 2CV (screw for the steering tube clamp).



Art.No.	Quality	needed qty
20122	3	



M7x50 / screw galvanized. Continuous thread.



Art.No.	Quality	needed qty
20112	3	



Screw M7x80, e.g. to for lamp tree 2cv on chassis



Art.No.	Quality	needed qty
20105	3	2

1104 screws + nuts



M8

M8, copper nut M8, for 13mm tool. Universal suitable e.g. for exhausts + exhaust manifolds.



Art.No.	Quality	needed qty
60129	3	1



M8

M8, nut for 12mm wrench. (Metal) (e.g. carburetor on intake manifold 2CV).



Art.No.	Quality	needed qty
10112	3	1



M8

M8, nut for 14mm wrench. (Metal) (e.g. caliper Renault Caravelle, R8, Alpine110...).



Art.No.	Quality	needed qty
21075	3	1



M8 x 18 striées

Washers corrugated M8x18 (French name: Striées). Content: 45 units. These grooved washers were original Installed at French vehicles!



Art.No.	Quality	needed qty
20278	2	1



striées M8 x 22

Washers corrugated M8x22 (French name: Striées). Content: 25 units. These grooved washers were original Installed at French vehicles!



Art.No.	Quality	needed qty
20277	2	1



M8x25

M8 x 25 screws, with 20mm head. The suitable for radiator grill securement to Citroën 11CV. This screw can be also universal used, for example fasten from bumpers. Or. No. 331101



Art.No.	Quality	needed qty
60273	3	4



M9

Box nut M9 (casing nut). 17 x 17mm



Art.No.	Quality	needed qty
21066	3	1



M9

M9, M9x1.25 flange nut. This M9 nut is somewhat poorly manufactured, but works well. Our M9 nuts 12123 are better.



Art.No.	Quality	needed qty
12074	4	1



M9

M9, nut M9x1.25. Low (flatten) version. Amount: 5mm. E.g. for the valve cover screw connection on the 11CV with D-engine. Or. No. 2372-S



Art.No.	Quality	needed qty
12385	2	1



M9 x 1,25

M9, nut M9x1,25. For example mounting drive shaft at the gearbox for 2CV. Amount: 9mm. Very good quality.



Art.No.	Quality	needed qty
12123	2	1



M9 x 42mm

M9, stud bolt, for the mounting of the drive shaft at the gearbox. Suitable for Citroën 2CV + Citroën DS. Measurement: M9x42mm.



Art.No.	Quality	needed qty
12182	3	1



M9

M9, washer. Dimension: 9.2 x 20 x 1,2mm.



Art.No.	Quality	needed qty
12386	2	1



M9

Toothed washer 9 mm. Or. No. Citroën 7903056125



Art.No.	Quality	needed qty
20142	3	1

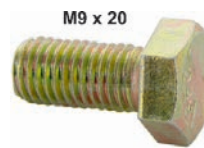

M9 x 20

Screw M9x20, gold chromate, FVP Bolts



Art.No.	Quality	needed qty
21077	3	1



M9 x 30

Screw M9x30, FVP Bolts



Art.No.	Quality	needed qty
21056	3	1



M9x30

Screw M9x30, gold chromate, FVP Bolts



Art.No.	Quality	needed qty
20297	3	1



M9x35

Screw M9x35



Art.No.	Quality	needed qty
20298	3	1



M9 x 50

Screw M9x50, gold chromate, FVP Bolts



Art.No.	Quality	needed qty
21079	3	1



M9 x 65
Screw M9x65



Art.No.	Quality	needed qty
20144	3	



Collars clip strap with lock (made from metal). Overall length: about 500mm. Width: 5,0mm. These universal clip straps were in former times Installed at many French car's. So also at radiator hoses, collar drive shafts etc.



Art.No.	Quality	needed qty
38271	3	



Rubber for engine bonnet lock, 2 pieces



Art.No.	Quality	needed qty
50069	3	



O-Ring Assortment, 386 pcs. 32 sizes R-01 - R-32, inner-ø 3-44 mm, oil-, petrol- and acid-resistant. Made in Germany.



Art.No.	Quality	needed qty
20980	3	1



Aluminum sealing ring range. 300 sealing rings, from 9x1 to 28x26. Optimally for brake and engine.



Art.No.	Quality	needed qty
21026	3	1



Copper sealing ring range. 150 fittings.



Art.No.	Quality	needed qty
20971	2	1



expanding rivet with safety pin. (3,5mm) 100 pieces!



Art.No.	Quality	needed qty
18421	2	



expanding rivet with safety pin. (5,5mm) 30 pieces!



Art.No.	Quality	needed qty
18423	2	



Rivet, 4 mm (e.g. to fix the wind cowl 2cv)



Art.No.	Quality	needed qty
20162	3	12



Rosette 13/5mm with screw. Contents: 12 pieces + 12x screw 4mm/16mm. This rosette consists only of a punched-out sheet metal which has been nickel-plated. They are not as sturdy and pretty as our numbers 21143, 21144, 21145, but these rosettes are more like the original rosettes used in early Citroën 2CV, R4, Dauphine etc. Higher-quality vehicles were more likely to have our shiny alternatives (e.g. Citroën DS).



Art.No.	Quality	needed qty
21179	4	1



Rosette nickel plated. For 4mm screw. Outside diameter: 11mm. Height: 2,4mm. These rosettes were used for dashboard, door linings. Suitable for Citroën 2CV, DS, HY and in many Peugeot + Renault. Our rosettes are shiny and flanged at the back. This makes them very stable.



Art.No.	Quality	needed qty
21144	3	



Rosette nickel plated. For 4mm screw. Outside diameter: 12,7mm. Height: 2,5mm. These rosettes were used for dashboard, door linings. Suitable for Citroën 2CV, DS, HY and in many Peugeot + Renault. Our rosettes are shiny and flanged at the back. This makes them very stable.



Art.No.	Quality	needed qty
21145	3	



Rosette nickel plated. For 5mm screw. Outside diameter: 13mm. Height: 3,0mm. These rosettes were used for dashboard, door linings. Suitable for Citroën 2CV, DS, HY and in many Peugeot + Renault. Our rosettes are shiny and flanged at the back. This makes them very stable.



Art.No.	Quality	needed qty
21143	3	



Hose clamp 11-17mm, especially for radiator hose. Vintage look. Embossed band with raised edges. This prevents the hose from being damaged. Small screw housing with 7mm hexagon head screw (with slot). Normal, modern hose clamps squeeze the hose. This is completely avoided with these clamps. And they even look better.



Art.No.	Quality	needed qty
50216	1	



Hose clamp 13-20mm, especially for radiator hose. Vintage look. Embossed band with raised edges. This prevents the hose from being damaged. Small screw housing with 7mm hexagon head screw (with slot). Normal, modern hose clamps squeeze the hose. This is completely avoided with these clamps. And they even look better.



Art.No.	Quality	needed qty
50217	1	

1104 screws + nuts

15-24mm



Hose clamp 15-24mm, especially for radiator hose. Vintage look. Embossed band with raised edges. This prevents the hose from being damaged. Small screw housing with 7mm hexagon head screw (with slot). Normal, modern hose clamps squeeze the hose. This is completely avoided with these clamps. And they even look better.



Art.No.	Quality	needed qty
50218	1	

38-50mm



Hose clamp 38-50mm, especially for radiator hose. Vintage look. Embossed band with raised edges. This prevents the hose from being damaged. Small screw housing with 7mm hexagon head screw (with slot). Normal, modern hose clamps squeeze the hose. This is completely avoided with these clamps. And they even look better.



Art.No.	Quality	needed qty
50223	1	

19-28mm



Hose clamp 19-28mm, especially for radiator hose. Vintage look. Embossed band with raised edges. This prevents the hose from being damaged. Small screw housing with 7mm hexagon head screw (with slot). Normal, modern hose clamps squeeze the hose. This is completely avoided with these clamps. And they even look better.



Art.No.	Quality	needed qty
50219	1	

40-56mm



Hose clamp 40-56mm, especially for radiator hose. Vintage look. Embossed band with raised edges. This prevents the hose from being damaged. Small screw housing with 7mm hexagon head screw (with slot). Normal, modern hose clamps squeeze the hose. This is completely avoided with these clamps. And they even look better.



Art.No.	Quality	needed qty
50224	1	

22-32mm



Hose clamp 22-32mm, especially for radiator hose. Vintage look. Embossed band with raised edges. This prevents the hose from being damaged. Small screw housing with 7mm hexagon head screw (with slot). Normal, modern hose clamps squeeze the hose. This is completely avoided with these clamps. And they even look better.



Art.No.	Quality	needed qty
50220	1	

50-65mm



Hose clamp 50-65mm, especially for radiator hose. Vintage look. Embossed band with raised edges. This prevents the hose from being damaged. Small screw housing with 7mm hexagon head screw (with slot). Normal, modern hose clamps squeeze the hose. This is completely avoided with these clamps. And they even look better.



Art.No.	Quality	needed qty
50225	1	

26-38mm



Hose clamp 26-38mm, especially for radiator hose. Vintage look. Embossed band with raised edges. This prevents the hose from being damaged. Small screw housing with 7mm hexagon head screw (with slot). Normal, modern hose clamps squeeze the hose. This is completely avoided with these clamps. And they even look better.



Art.No.	Quality	needed qty
50221	1	

57-75mm



Hose clamp 57-75mm, especially for radiator hose. Vintage look. Embossed band with raised edges. This prevents the hose from being damaged. Small screw housing with 7mm hexagon head screw (with slot). Normal, modern hose clamps squeeze the hose. This is completely avoided with these clamps. And they even look better.



Art.No.	Quality	needed qty
50226	1	

32-44mm



Hose clamp 32-44mm, especially for radiator hose. Vintage look. Embossed band with raised edges. This prevents the hose from being damaged. Small screw housing with 7mm hexagon head screw (with slot). Normal, modern hose clamps squeeze the hose. This is completely avoided with these clamps. And they even look better.



Art.No.	Quality	needed qty
50222	1	



Hose clamp 120-140mm



Art.No.	Quality	needed qty
20263	3	

15 - 20mm



hose clamp for 15-20mm.



Art.No.	Quality	needed qty
51020	3	



hose clamp for 40-60mm.



Art.No.	Quality	needed qty
51013	3	



Hose clamp Screwdriver hexagon (7mm). Flexible. Ideal for our hose clamps with raised edges.



Art.No.	Quality	needed qty
50227	1	



Lubrication nipple cap from synthetic. Color: Red.



Art.No.	Quality	needed qty
12396	1	



Lubricate nipple with M7 thread. Suitable for Citroën 2CV, DS, 11CV, HY, etc.



Art.No.	Quality	needed qty
12023	3	4



Screw for SEIMA turn signal cap + taillight cap. Suitable for Citroën 2CV. Citroën HY. Citroën DS BREAK. Or. No. AM544-17B



Art.No.	Quality	needed qty
16460	3	8



Screw cross lens head (3,9x16) from stainless steel, for round indicator + stop light. For Seima + AXO caps. Only suitable for synthetic bases. Per piece.



Art.No.	Quality	needed qty
21137	3	4



Screw cross lens head (4,8x22) in stainless steel. Per piece.



Art.No.	Quality	needed qty
21166	3	4



Screw cross lens head (4,8x32) in stainless steel. Per piece.



Art.No.	Quality	needed qty
21167	3	4



Cross lens head screw (M4x10) from stainless steel, for round indicator + stop light. For Seima + AXO caps. Only suitable for metal bases. Per piece



Art.No.	Quality	needed qty
21138	3	4



Cross lens head screw (M4x12) from high-grade steel, for round indicator + stop light. For Seima + AXO caps. Only suitable for metal bases. Per piece



Art.No.	Quality	needed qty
21139	3	4



Screw M10x50



Art.No.	Quality	needed qty
20212	3	2



screw M8x16



Art.No.	Quality	needed qty
20280	3	



Screw set M5-M8 galvanizes. Consisting of: 20x M5x20, 15x M5x30, 25x M6x16, 20x M6x20, 12x M6x25, 8x M6x30, 10x M7x20, 8x M7x30, 15x M8x20, 10x M8x30, 8x M8x40. Altogether 151 screws in a clear synthetic box.



Art.No.	Quality	needed qty
20237	2	1



Flywheel screw. M9 x 18mm. Suitable for Citroën 11D, Citroën HY > 06/1962. Citroën DS > 06/1962. Per piece. Or. No. D121-92



Art.No.	Quality	needed qty
60177	3	6



Cotter Pin Assortment, 555 pcs



Art.No.	Quality	needed qty
20978	3	1



Inclination rivet 3mm.



Art.No.	Quality	needed qty
17136	3	



Circlips (shaft retaining rings) range 3-32mm. Outside! 300 pieces!



Art.No.	Quality	needed qty
21013	3	1

1104 screws + nuts



Circlips (shaft retaining rings) range 3-32mm, inside. 300 pieces!



Art.No.	Quality	needed qty
21012	3	1



Stud bolt M7 on M8. 45mm lengths. Special production!



Art.No.	Quality	needed qty
31219	2	



M7, stud bolt M7x28. (e.g. screening plate on manifold Citroën DS). Or. No. ZC9616135W



Art.No.	Quality	needed qty
31206	3	3



Stud bolt M7x43mm (thread M7x1). This stud bolt are installed, for example, at the exhaust elbow with Citroën 15CV. Elbow pipe Citroën DS, etc. Universally fitting!



Art.No.	Quality	needed qty
60200	3	13



Stud bolt M8 on M10. 38mm lengths. Special production!



Art.No.	Quality	needed qty
31220	2	



Toothed disk, dished, M7, outside diameter 14mm. (e.g. drum mounting, striker plate etc.)



Art.No.	Quality	needed qty
60650	3	24



electrical material generally 1105

<p>1,5 - 2,5mm²</p>	<p>Cable Connector blue</p> <table border="1"> <tr> <th>Art.No.</th> <th>Quality</th> <th>needed qty</th> </tr> <tr> <td>14472</td> <td>3</td> <td></td> </tr> </table>	Art.No.	Quality	needed qty	14472	3		
Art.No.	Quality	needed qty						
14472	3							
<p>protection caoutchouc pour casse de batterie Battery pole protecting cap Batteripol Schutzkappe</p>	<p>Battery pole protecting cap from rubber. Color: red. Length: 52mm. Width: 35mm. Short side - centric cable inlet.</p> <table border="1"> <tr> <th>Art.No.</th> <th>Quality</th> <th>needed qty</th> </tr> <tr> <td>14555</td> <td>3</td> <td>1</td> </tr> </table>	Art.No.	Quality	needed qty	14555	3	1	
Art.No.	Quality	needed qty						
14555	3	1						
<p>protection caoutchouc pour casse de batterie Battery pole protecting cap Batteripol Schutzkappe</p>	<p>Battery pole protecting cap from rubber. Color: red. Length: 52mm. Width: 35mm. Long side left - cable inlet down.</p> <table border="1"> <tr> <th>Art.No.</th> <th>Quality</th> <th>needed qty</th> </tr> <tr> <td>14558</td> <td>3</td> <td>1</td> </tr> </table>	Art.No.	Quality	needed qty	14558	3	1	
Art.No.	Quality	needed qty						
14558	3	1						
<p>protection caoutchouc pour casse de batterie Battery pole protecting cap Batteripol Schutzkappe</p>	<p>Battery pole protecting cap from rubber. Color: red. Length: 52mm. Width: 35mm. Long side on the right - cable inlet down.</p> <table border="1"> <tr> <th>Art.No.</th> <th>Quality</th> <th>needed qty</th> </tr> <tr> <td>14556</td> <td>3</td> <td>1</td> </tr> </table>	Art.No.	Quality	needed qty	14556	3	1	
Art.No.	Quality	needed qty						
14556	3	1						
<p>protection caoutchouc pour casse de batterie Battery pole protecting cap Batteripol Schutzkappe</p>	<p>Battery pole protecting cap from rubber. Color: black. Length: 52mm. Width: 35mm. Short side - centric cable inlet.</p> <table border="1"> <tr> <th>Art.No.</th> <th>Quality</th> <th>needed qty</th> </tr> <tr> <td>14554</td> <td>3</td> <td>1</td> </tr> </table>	Art.No.	Quality	needed qty	14554	3	1	
Art.No.	Quality	needed qty						
14554	3	1						
<p>www.citroen.fr www.franzose.de</p>	<p>Battery pole protecting cap from rubber. Color: black. Length: 52mm. Width: 35mm. Long side on the right - cable inlet down.</p> <table border="1"> <tr> <th>Art.No.</th> <th>Quality</th> <th>needed qty</th> </tr> <tr> <td>14557</td> <td>3</td> <td>1</td> </tr> </table>	Art.No.	Quality	needed qty	14557	3	1	
Art.No.	Quality	needed qty						
14557	3	1						
	<p>Crimping pliers for round plugs. Suitable for the uninsulated round plugs 3mm + 4mm. Brand quality KNIPEX</p> <table border="1"> <tr> <th>Art.No.</th> <th>Quality</th> <th>needed qty</th> </tr> <tr> <td>21146</td> <td>2</td> <td>1</td> </tr> </table>	Art.No.	Quality	needed qty	21146	2	1	
Art.No.	Quality	needed qty						
21146	2	1						
<p>0,5 - 1,5mm²</p>	<p>Flat plug red</p> <table border="1"> <tr> <th>Art.No.</th> <th>Quality</th> <th>needed qty</th> </tr> <tr> <td>14470</td> <td>3</td> <td></td> </tr> </table>	Art.No.	Quality	needed qty	14470	3		
Art.No.	Quality	needed qty						
14470	3							
<p>25x 3,0x100mm 25x 3,0x120mm 25x 3,6x200mm</p>	<p>Cable tie assortment (black). 75 pieces. Content: 25 cable ties 3.0 x 100 mm, 25 cable ties 3.0 x 120 mm, 25 cable ties 3.6 x 200 mm</p> <table border="1"> <tr> <th>Art.No.</th> <th>Quality</th> <th>needed qty</th> </tr> <tr> <td>20287</td> <td>3</td> <td>1</td> </tr> </table>	Art.No.	Quality	needed qty	20287	3	1	
Art.No.	Quality	needed qty						
20287	3	1						

<p>Rehe plate double, pour connexion de câble à câble Insulated cable plug with 2 connectors, 1 cable to 1 cable Kabelfreischer 2Stab, 1 zu 1</p>	<p>Insulated cable plug, with 2 connectors (to combine connections). From 1 cable to 1 cable</p> <table border="1"> <tr> <th>Art.No.</th> <th>Quality</th> <th>needed qty</th> </tr> <tr> <td>20177</td> <td>3</td> <td></td> </tr> </table>	Art.No.	Quality	needed qty	20177	3		
Art.No.	Quality	needed qty						
20177	3							
	<p>Insulated cable plug, from 1 cable to 1 cable</p> <table border="1"> <tr> <th>Art.No.</th> <th>Quality</th> <th>needed qty</th> </tr> <tr> <td>20178</td> <td>3</td> <td></td> </tr> </table>	Art.No.	Quality	needed qty	20178	3		
Art.No.	Quality	needed qty						
20178	3							
	<p>Cable connectors, isolated from 1 cable to 2 cables</p> <table border="1"> <tr> <th>Art.No.</th> <th>Quality</th> <th>needed qty</th> </tr> <tr> <td>20176</td> <td>3</td> <td></td> </tr> </table>	Art.No.	Quality	needed qty	20176	3		
Art.No.	Quality	needed qty						
20176	3							
<p>160x</p>	<p>Cable connector set, 160 pieces.</p> <table border="1"> <tr> <th>Art.No.</th> <th>Quality</th> <th>needed qty</th> </tr> <tr> <td>20136</td> <td>3</td> <td></td> </tr> </table>	Art.No.	Quality	needed qty	20136	3		
Art.No.	Quality	needed qty						
20136	3							
	<p>Ground cable (battery ground strap), with battery pole clamp and ring tongue. Length: 250mm. Cable diameter: 22mm². Made in the European Union. Universal fitting.</p> <table border="1"> <tr> <th>Art.No.</th> <th>Quality</th> <th>needed qty</th> </tr> <tr> <td>14565</td> <td>3</td> <td>1</td> </tr> </table>	Art.No.	Quality	needed qty	14565	3	1	
Art.No.	Quality	needed qty						
14565	3	1						
	<p>Earth cable (battery ground strap), with battery pole clamp and eye ring. Length: 285mm. Made one in the European Union. Universal fitting.</p> <table border="1"> <tr> <th>Art.No.</th> <th>Quality</th> <th>needed qty</th> </tr> <tr> <td>14564</td> <td>3</td> <td>1</td> </tr> </table>	Art.No.	Quality	needed qty	14564	3	1	
Art.No.	Quality	needed qty						
14564	3	1						
	<p>Ground cable (battery ground strap), with battery pole clamp and ring tongue. Length: 300mm. Cable diameter: 22mm². Made in the European Union. Universal fitting.</p> <table border="1"> <tr> <th>Art.No.</th> <th>Quality</th> <th>needed qty</th> </tr> <tr> <td>14566</td> <td>3</td> <td>1</td> </tr> </table>	Art.No.	Quality	needed qty	14566	3	1	
Art.No.	Quality	needed qty						
14566	3	1						
	<p>Ground cable (battery ground strap), with battery pole clamp ring tongue. Length: 350mm. Cable diameter: 22mm². Made in the European Union. Universal fitting.</p> <table border="1"> <tr> <th>Art.No.</th> <th>Quality</th> <th>needed qty</th> </tr> <tr> <td>14567</td> <td>3</td> <td>1</td> </tr> </table>	Art.No.	Quality	needed qty	14567	3	1	
Art.No.	Quality	needed qty						
14567	3	1						

1
2
3
4
5
6
7
8
9
10
11
12
13
14

1105 electrical material generally

1403 spare part catalogue



Ground cable (battery ground strap), with battery pole clamp and ring tongue. Length: 400mm. Cable diameter: 22mm². Made in the European Union. Universal fitting.



Art.No.	Quality	needed qty
14568	3	1



Ground cable (battery ground strap), with battery pole clamp and ring tongue. Length: 500mm. Cable diameter: 22mm². Made in the European Union. Universal fitting.



Art.No.	Quality	needed qty
14570	3	1



Positive cable (battery to starter motor). Overall length: 500mm. Cable diameter: 16mm². Made in the European Union. Universal fitting.



Art.No.	Quality	needed qty
14561	3	1



Eye ring red, 5mm



Art.No.	Quality	needed qty
14471	3	1



Round plug male, red



Art.No.	Quality	needed qty
14469	3	1



Round plug fememin, red



Art.No.	Quality	needed qty
14468	3	1



Heat shrink tubing (kit from 100). These handy sheaths form a protective water resistant insulation over exposed wiring and electrical connections. Designed for automotive use. Supplied in a plastic organiser.



Art.No.	Quality	needed qty
21045	1	1



Hazard warning signal switch, universal, 12volt, Manufacturer HELLA The switcher uses the actual indicator-relais. easy to fit.



Art.No.	Quality	needed qty
50104	2	1

1403 spare part catalogue



Service manual - workshop manual, for Citroën HY. No. 444. Language: German. About 150 pages.



Art.No.	Quality	needed qty
48002	4	1



Spare parts catalog, for Citroën HY Essence + Diesels. Simplified catalog, edition 1980, predominantly exploded views. About 100 sides, little text.



Art.No.	Quality	needed qty
48001	4	1



1
2
3
4
5
6
7
8
9
10
11
12
13
14

GENERAL SALES TERMS AND CONDITIONS Der Franzose Automobiltechnik GmbH (below „seller“ mentioned“)

§ 1 General – Scope of application

(1) Our Sales Terms and Conditions shall apply in any case. Other Sales Terms and Conditions shall not apply, unless expressly agreed in writing. Our Sales Terms and Conditions shall also apply even if we know that the Buyer's conditions are differing from our General Sales Terms and Conditions. <https://www.franzose.de/en/CMS/AGB/>

(2) For traders, for legal persons of public law or public-law special property as defined under § 310 paragraph 1. BGB our Sales Terms and Conditions shall also unrestricted apply.

§ 2 Offer and contract conclusion

(2.1) Online orders

(2.1.1) The product description in the seller's online shop do not constitute any firm offer from the Seller but merely enables the Buyer to submit a binding submission.

(2.2) The Buyer may submit a submission using the online-shop order form. In this case the customer submits a firm submission to the Seller by clicking the button „order“ after filling in his shopping cart. The transmission of the submission by the Buyer is also possible by postal service, e-mail, fax or phone.

(2.3) The seller may accept customer's proposal within five days:

- sending a written order confirmation to the Buyer by fax or e-mail. The access to the order confirmation is decisive.
- by delivering ordered products to the Buyer. The access to the delivery is decisive.
- requesting the Buyer to pay after ordering.

Provided that several of the aforementioned alternatives occur, the contract will be concluded as soon as one of the aforementioned alternatives firstly occurs. The non-acceptance of customer's submission by the Seller within the given deadline means the refusal of the submission and it releases the buyer of his statement of intent.

(2.4) The period of order acceptance shall start the day after Buyer's submission dispatch and shall end at the end of the fifth day following submission dispatch.

(2.5) The contract's content of the online order form will be recorded by the Seller and shall be sent to the Buyer in written form together with these General Sales Terms and Conditions (for example via e-mail, fax or letter) after the receipt of Buyer's order submission. In addition contract's content will be recorded on the Seller's website. Data record is accessible for the Buyer via the password protected customer account under the condition that he has created a customer account before submitting his order.

(2.6) The Buyer has the opportunity to correct the entered data prior to firm submission transmission via keyboard and mouse function. Beyond prior to submission transmission the entered data will be displayed in a confirmation screen window and can be corrected as well via keyboard and mouse function.

(2.7) English only is contractual language.

(2.8) Order processing and contacting usually take place via e-mail and automated order processing. The customer has to ensure that the email-address he provides during order process is accurate in order to receive e-mails sent to him by the Seller. Particularly, the Buyer has to ensure that e-mails sent by the Seller or a by third party can be delivered even in case of active SPAM filters.

(3) Orders

(3.1) If the submission is in accordance with § 145 BGB it can be confirmed by us within 2 weeks. The acceptance can also occur via spoken or written declaration, by order confirmation in written form, or order confirmation in text form (email, fax) or by the delivery of the goods.

§ 3 Right of withdrawal

Traders, legal persons of public law and special property as defined under § 310 paragraph 1. BGB have no right of withdrawal.

§ 4 Prices – Terms of payment

(1) Our prices are always ex-work prices exclusive shipping cost and packing charges which are separately shown on the invoice if no special conditions are mentioned on the order confirmation. Shipping cost are invoiced according to the effective „shipping-index“. In case of duties and taxes it shall be separably invoiced to the Buyer by the forwarder (for instance DHL).

(2) Our prices include VAT which is invoiced at the official rate of date of invoice and shown separately on the invoice.

Our prices for non-european customers are exclusive VAT as soon as the Buyer communicates his non-euro-

pean address. If the non-european Buyer picks up the goods at Seller's head office he will have to pay the effective VAT. The paid VAT will not be refunded by the Seller even not after the exportation to the non european country.

(3) Discount may not be deducted without previous written agreement.

(4) If no special term of payment is mentioned in the order confirmation the total amount has to be paid without deduction within 10 days after date of invoice. Regarding overdue payment legal provisions shall apply.

§ 5 - Place of jurisdiction - Place of execution

(1) If the Buyer is trader the place of jurisdiction is our place of business; but we are also authorized to take him to the court of his place of residence.

(2) German legislation shall be applied; the application of UN-Sales Convention is excluded.

(3) Except contrary mention on the order confirmation our place of business is place of execution.

§ 5 Set-off interdiction – Right of retention

Set-off is only allowed to the Buyer if his counterclaims are legally stated, uncontested and approved by us. Furthermore the Buyer is allowed to apply his right of retention if his counterclaim is based on the same contract relation.

§ 6 Delivery time – Responsibility in case of delivery delay

(1) The beginning of the delivery time which we confirmed implies that all possible technical questions have been cleared.

(2) The compliance of our delivery obligation implies the accurate implementation of Buyer's obligations in due time. We reserve ourself the right of objection for non-complited contract.

(3) In case of default of acceptance or non-implementation of any obligation by the Buyer, we are authorized to claim a compensation for the caused damages and for the possible additional expenditures. All rights for further pretensions reserved.

(4) Provided that the conditions written in § 3 are existent, the risk of a casual damage or the risk of a casual deterioration of object of purchase is carried by the Buyer as soon as the payment or the acceptance of the delivery has been delayed.

(5) We are responsible under legal provisions as far as the fundamental contract is a time deal. We are also responsible under legal provisions if the Buyer, following to a delayed delivery due to the Seller, declares that he is no more interested in further fulfillment of contract.

(6) We are also responsible under legal provisions as far as the delivery delay is due to intentional or grossly negligent breach of one of our obligations; we also responsible under legal provisions for the possible negligence of our representatives or auxiliary persons. As far as the delivery delay is not due to an intentional or grossly negligent breach of contract from our side our responsibility for damage indemnity is strictly limited to the foreseeable and concrete damage.

(7) We are responsible under legal provisions as far as the delivery delay is due to our intentional or non-negligent breach of contract; in such a case our responsibility for damage indemnity is strictly limited to the foreseeable and concrete damage.

(8) Furthermore if we are responsible for delivery delay we compensate for every complete week 3 % of value of goods , maximum 15 % of value of goods, according to a standart delivery delay all-in indemnity .

(9) All rights for further pretensions reserved.

§ 7 Collection by the customer

As far as a collection of the goods by the Buyer has been agreed no shipping cost will be invoiced. The Buyer has to collect the goods at the buyer's place of business after arrangement. The Seller has to inform the Buyer by Email that the goods can be collected.

§ 8 Transfer of risk - Packing charges

(1) Our prices are always ex-work prices if no special conditions are mentioned on the order confirmation.

(2) Packaging will not be withdrawn except pallets. The Buyer has to dispose of packages at his own's expense.

(3) Deliveries are always insured. Corresponding cost are borne by the Buyer.

§ 9 Warranty for defects – Limitation of liability in time

(1) Warranty claims from the Buyer implies that he duly complied with his obligation of investigation and reproval (§ 377 HGB)

(2) Warranty claims prescribe 12 months after the date

of delivery to the Buyer's. In case of claim for compensation following to intentional or non-negligent damage of the user or in case injury to life, bodily injury or injury to health, legal provisions shall be applied.

(3) If the object of purchase shows a defect that already existed at the time of transfer of risk, despite all dedicated carefulness, subject to claim in due time, we shall either correct or replace the concerned product. The time limit for correction given to us should be appropriate (at least 2 weeks). Right of recourse will not be affected by above mentioned rule.

(4) If supplementary performance fails the Buyer may withdraw from the contract or reduce his pay, regardless of possible damage compensation pretensions.

(5) Damage compensation pretensions are not receivable in case of insignificantly deviations from the agreed configuration, from usability, or in case of natural abrasion or wastage, or defective fitting and also in case of damages occurring after the transfer of risk and due to wrong or negligent handling, or excessive strain, unsuitable utilities or defective fitting. In case of improperly repair work or modifications made by the Buyer or by a third party damage compensation pretensions are excluded as per for the outcome of these acts.

(6) Claims from the Buyer regarding the necessary charges for correction, in particular transportation charges, travel charges, labour costs and material cost are excluded. If the product delivered by us has been retroactively brought to another place than the Buyer's place of business, except the movement is due to the conventional usage of the product.

(7) The Buyer's right of recourse against us only exists if the Buyer has not concluded with his consumer any agreement about exceeding the legal provisions of warranty claims. Regarding the range of buyer's right of recourse, § 6 shall apply.

§ 10 Used parts and NOS parts – Responsibility

Defect liability for traders.

(1) For used parts defect liability is limited to one year. After one year any claim will be rejected. Deceit and fraudulent claims odr defects or pretensions regarding defect liability assumed by us for one product are excluded from this rule.

(2) For used parts liability is limited to one year. After one year any claim will be rejected. For reconditioned parts liability is limited to one year. After one year an claim will be rejected. Reconditioned parts are used parts which have been optically and technically worked off or repaired.

§ 11 Joint liability

(1) A larger compensation responsibility as per § 9 and § 10 without consideration of the legal nature of claim is excluded. This particularly applies to claims based on fault at contract conclusion, following to any violation of obligations or any culpable damage compensation claim under § 823 BGB.

(2) The exclusion or restriction of our responsibility shall apply to our employees, workers, collaborators, representatives and auxiliary employees as far as their personal responsibility is concerned.

§ 12 Title retention

(1) We reserve ourselves the right of retention for the object of purchase till all payments for contract are received.

In case of contract violation by the Buyer, particularly in case of overdue payment we are authorized to take the object of purchase back. Withdrawal does not mean contract cancellation. Except explicit declaration in written form. The seizure of the object of purchase always means our withdrawal from the contract. After the seizure we are authorized to sell the object of purchase. The commercial benefit less commercial costs should be deducted from the amount of Buyer's commitment.

(2) The Buyer is obliged to care for the object of purchase; particularly he is obliged to ensure the contractual object at its original value against damage by fire, water and theft at his own expense. If any maintenance or service work is necessary the buyer has to perform it at his own expense.

(3) In case of distraint or any intervention by a third party the Buyer must inform us immediately so that we can take legal action under § 771 ZPO. If the third party is not able to refund court and extrajudicial costs as per § 771 ZPO the Buyer will assume the caused loss.

§ 13 - Place of jurisdiction - Place of execution

(1) If the Buyer is trader the place of jurisdiction is our place of business; but we are also authorized to take him to the court of his place of residence.

(2) German legislation shall be applied; the application of UN-Sales Convention is excluded.

(3) Except contrary mention on the order confirmation our place of business is place of execution.

Vehta, February 2021

Oh, how
beautiful!





To make an order:
 Phone: +49 4441 - 91 61 912
 E-Mail: info@franzose.com
www.franzose.com

Der Franzose
 Automobiltechnik GmbH
 Manager Director:
 Ansgar Olberding
 Registered office: Germany
 Osloer Str. 9-11, 49377 Vechta

HRB Oldenburg 111051
 VAT No: DE 114162160
 Tax No.: FA Vechta 68/203/66446
 Bank details: Volksbank Vechta
 IBAN: DE44 2806 4179 0137 5890 00
 BIC: GENODEF1VEC

Ordering / Commandes



Tel.: +49 4441 - 91 61 910
 Fax: +49 4441 - 91 61 920
 E-Mail: info@franzose.de



Phone: +49 4441 - 91 61 913
 Fax: +49 4441 - 91 61 920
 E-Mail: contact@cipere.fr



Phone: +49 4441 - 91 61 917
 Fax: +49 4441 - 91 61 920
 E-Mail: info@franzose.com



Phone: +49 4441 - 91 61 916
 Fax: +49 4441 - 91 61 920
 E-Mail: info@franzose.com